

VICTORIA COLLEGE

Catalog 2024-2025



This copy is for internal advising purposes only.

Please refer all students to the VC website.

www.VictoriaCollege.edu/Catalog

Please Note

Information in Victoria College's 2024-2025 Catalog is accurate as of April 19, 2024.

Revisions made after April 19, 2024 are noted within the document.

Please refer to the Victoria College website at VictoriaCollege.edu for current information.

While the College endeavors to provide current and accurate information in this catalog, information contained herein is for informational purposes only and is subject to change without notice. Courses, faculty assignments, prerequisites, graduation or completion requirements, standards, tuition and fees, policies, practices, and programs may be changed from time to time. Courses may not be offered each semester or each year. If you have any questions, you may contact the appropriate department or unit at the contact numbers in this catalog.

Notwithstanding the information provided in this catalog, the College retains the exclusive right to judge academic proficiency and may decline to award any degree, certificate, or other evidence of successful completion of a program, curriculum, or course of instruction based thereupon. The College retains the exclusive right to interpret this catalog; to amend, modify, suspend, or cancel any of the policies, programs, or practices in this catalog; and to take any action in the administration of the policies, programs, or practices in this catalog that the College deems appropriate.



General Catalog for 2024-2025
May 2024 – VOL. LXXXVI, No. 1

Accreditation

Victoria College is accredited by the Southern Association of Colleges and Schools Commission on Colleges (SACSCOC) to award associate degrees. Victoria College also may offer credentials and certificates at approved degree levels. Questions about the accreditation of Victoria College may be directed in writing to the Southern Association of Colleges and Schools Commission on Colleges at 1866 Southern Lane, Decatur, GA 30033-4097, by calling (404) 679-4500, or by using information available on SACSCOC's website (www.sacscoc.org).

Statement of Nondiscrimination

Victoria College does not discriminate on the basis of race, color, religion, national origin, gender, sexual orientation, pregnancy, age, disability, genetic information, marital status, amnesty, veteran's status, limited English proficiency, or any other legally protected characteristic. It is our policy to comply, fully, with the nondiscrimination provision of all state and federal rules and regulations. The following person has been designated to handle inquiries regarding the nondiscrimination policies: Executive Director of Human Resources; 2200 E. Red River Street; Victoria, TX 77901; (361) 572-6463; Terri.Kurtz@VictoriaCollege.edu.

VC Mission, Vision, & Values

Vision

Our Community, Our College: Improving Lives, Strengthening Communities

- Empowering each student to achieve excellence in an environment that cultivates personal relationships among students, faculty, and staff.
- Being the catalyst for educational attainment, economic growth, and cultural enrichment in partnership with business, industry, community groups, and all levels of education.

Mission

Victoria College is a public, open-admission college. Our mission is to provide educational opportunities and services for our students and the communities we serve. Victoria College provides:

Associate Degrees & Certificates – Programs leading to the Associate of Arts, Associate of Science, Associate of Applied Science, and Certificates that meet the needs of the students and communities within our service area.

University Transfer – Academic courses that apply to baccalaureate degrees and meet the educational needs of students planning to transfer to a university.

Career & Technical Education – Credit courses and programs designed to satisfy local and regional employer demands and meet individuals' workforce training needs.

Developmental Education – Compensatory education courses consistent with open-admission policies designed to prepare students effectively for success in college-level studies.

Continuing Education – Noncredit courses and programs that meet the immediate technical and occupational skills needs of employers and the individual, and fulfill the personal enrichment and cultural needs of the individual and the community.

Adult Education – Adult education, basic skills, and English as a second language instructional programs that meet the specific educational needs of our adult constituency.

Student Support – Services and activities that support student success, including academic guidance and counseling services.

Cultural & Intellectual Outreach – Educational activities and events that enhance our community's quality of life.

Values

Victoria College's commitment to its mission is guided by the following values:

We value integrity. Victoria College will foster an environment of respect, honesty, openness, and fairness and will promote responsible stewardship of resources and public trust.

We value respect for the unique characteristics and abilities of individuals. Victoria College will welcome and promote diversity among students, faculty, staff, and our community, while cultivating a respectful, collegial, and accessible working and learning environment.

We value student achievement and student success. Victoria College will create learning opportunities that challenge our students and help them meet their educational goals.

We value excellence. Victoria College will strive to achieve the highest standards of performance in teaching and in the services we offer students, colleagues, and our community.

TABLE OF CONTENTS

VISION, MISSION, & VALUES	4	How to Completely Withdraw from the College.....	38
TERMS TO KNOW	7	Deadline to Withdraw Without Consequence.....	39
IMPORTANT DATES & NUMBERS	9	Effects of Course Load Reduction/Total Withdrawals	39
Campus Contact Numbers	11	Distance Education.....	39
Academic Calendar – Year at a Glance	12	Final Exams	40
ADMISSIONS & ACADEMIC REGULATIONS	15	Dean's List.....	40
How to Apply for Admissions.....	16	Catalog Year Designation for Degree and/or Certificate Requirements ..	40
Application for Admissions.....	18	Graduation Participation & Honors	41
Admission to College	19	Transfer of Credit	41
Required State Testing	19	Transfer Disputes.....	41
Immunizations	21	Transfer Credit Policy.....	42
Residency Requirements.....	21	Transfer of Credits from Another Institution to VC.....	42
Pirate Orientation.....	22	Job Competency Guarantee.....	42
Transcript Requests.....	22	GENERAL REGULATIONS	43
Campus SaVE Act.....	22	Student Conduct.....	44
Learning Frameworks.....	22	Attendance.....	46
Texas Guided Pathways.....	22	Instructor-Initiated Withdrawals (Drops).....	46
Students' Right to Review Information	22	Family Education Rights & Privacy Act of 1974.....	47
Curriculum	23	Directory Information	47
Core Curriculum	23	Confidentiality and Access of Student Records	47
Degree/Certificate Requirements	25	Transcripts	47
Graduation Application	25	Name, Social Security Number, Contact Information Changes.....	47
Associate of Arts Interdisciplinary Studies Degree	26	Messages & Deliveries to Students	47
Associate of Science Interdisciplinary Studies Degree.....	27	Graduation, Employment, & Licensure Exam Pass Rates.....	47
Associate of Applied Science Degree.....	28	Crime Awareness and Prevention Programs.....	47
Certificate – Career & Technical Program.....	28	Clery Act Report	48
Certificate – Allied Health Program	28	Reporting Sexual Assault & Other Sexual Misconduct.....	48
Academic Transfer	28	Illegal Drugs or Alcohol.....	48
Developmental Education	29	Protections for Pregnant and Parenting Students (SB 412).....	48
Adult Education	29	TUITION AND FEES	49
Academic Standing.....	30	Tuition	50
Academic Warning.....	30	Fees.....	50
Academic Probation.....	30	Tuition Fees	52
Academic Suspension	30	High School Dual Enrollment Tuition & Fees	52
Grades.....	31	Additional Fees.....	52
Guided Pathways.....	31	Testing Fees	52
Registration	32	Course Fees	53
Semesters, Sessions & Credit	32	Laboratory Fees	53
Course Load	32	Residency Definitions for Tuition & Fee Purposes	54
Course Definitions	32	Residency Verification Requirements	54
Credit by Exam	33	Tuition Rebate	55
Locally Articulated Credit.....	36	Refund Policy.....	55
Classification of Students	36	Total Withdrawal Refund Table (Non-semester-Length).....	56
Auditing a Class.....	36	Refunds for Noncredit Courses.....	56
Fall 2006 and after Beginning Freshmen (30-Hour Rule)	36	Federal Financial Aid Return of Title IV Funds Policy	56
45-Hour Limit.....	36	State of Texas Tuition Exemption/Waiver Program.....	57
Legislation Concerning Physical Education Courses	37	FINANCIAL AID	59
Legislation Concerning Courses Attempted More Than Twice	37	Financial Aid	60
Schedule Changes	37	VC Foundation Board of Directors	60
Dropping a Course.....	37	Scholarships.....	61
Reinstatement Requests	37	Grants.....	62
Six Drop Rule	37	Loans.....	63
FAQs - Six Drop Rule	38		
FAQs - How to Drop a Class.....	38		

TABLE OF CONTENTS

Student Employment	64	NCCER Core Curriculum: Introductory Craft Skills.....	110
Satisfactory Academic Progress (SAP) Policy	64	Electrical.....	110
Repeating Courses – Procedures.....	65	Fiber Optics Training.....	110
Veterans' Benefits	66	Heating, Ventilating, & Air Conditioning (HVAC)	110
Workforce Solutions Golden Crescent.....	67	Millwright.....	111
Texas Workforce Solutions Vocational Rehabilitation Services.....	67	Pipefitting.....	111
		Plumbing.....	111
STUDENT SERVICES.....	69	Power Line Worker.....	112
Admissions & Records and Welcome Center	70	Scaffold Worker	112
Foster Care Liaisons.....	70	Warehouse Vehicle Operations	112
Advising & Counseling Services.....	70	Welding.....	112
Career & Transfer Services.....	70	Law Enforcement.....	113
Counseling Services.....	70	Motorcycle Safety	113
Disability Services	71	Real Estate	113
Support Services.....	71	Truck Driving.....	114
Veterans Services.....	71	Professional Continuing Education	114
Enrollment Services.....	71		
Financial Aid	71	ALLIED HEALTH CONTINUING EDUCATION (NONCREDIT).....	115
Childcare Assistance	72	Emergency Medical Services (noncredit).....	115
KEY Center.....	72	Electrocardiogram (EKG) Technician.....	115
Payments Office.....	72	Medical Assisting.....	115
Testing Center.....	72	Medical Coding.....	116
Student Life & Student Success Center	72	Medication Aide	116
Clubs & Student Organizations.....	72	Mental Health Technician.....	117
Phi Theta Kappa	73	Nurse Aide.....	117
National Society of Leadership & Success (NSLS)	73	Pharmacy Technician.....	118
Student Government	73	Phlebotomy.....	119
Student Resources	73	Veterinary Assistant	119
Student Computer Access	73	Professional Continuing Education	119
Student Identification Cards & Badges	73		
Success Coaching.....	74	ALL ABOUT VC	121
Learning Labs.....	74	VC Locations	122
Code of Student Conduct	74	Wireless (Wi-Fi) Buildings.....	123
		Flexible Schedules.....	123
PROGRAMS OF STUDY.....	75	Cultural Enrichment.....	123
Business Management.....	77	VC Board of Trustees.....	124
Criminal Justice	79	Administrative Council	124
Electronics Technology/Instrumentation	81	Instructional Council	124
Emergency Medical Services	84	Directors	124
Network Engineering Technology & Cloud Computing	86	Faculty	125
Nursing-Associate Degree.....	89	History of VC.....	130
Nursing-LVN-ADN Transition	92	Main Campus Buildings.....	130
Nursing-Vocational.....	95		
Physical Therapist Assistant	98	MATH PATHWAYS	133
Process Technology.....	100		
Respiratory Care.....	102	READING AND WRITING PATHWAYS.....	137
Welding.....	104		
		COURSE DESCRIPTIONS	141
WORKFORCE & CONTINUING EDUCATION (NONCREDIT).....	107		
Academy of Lifelong Learning	109		
Automotive Service Excellence (ASE) Certification Testing.....	109		
Carpentry.....	109		
Computer Applications.....	109		
Construction Site Safety Technician (CSST)	109		
Employee Training	109		
Environmental Protection Agency (EPA) Technician Certification	110		

Terms To Know

These are the terms which apply to college and university activities. They are common to institutions of higher learning throughout the country.

Academic Advisor: VC staff member of the Advising & Counseling Services Office, whose goal is to assist students with academic planning and degree requirements.

See page 183 for Academic Intervention and Academic Recovery

Academic Probation: Students who have been placed on academic warning and are unable to increase their cumulative GPA to a 2.0 or higher within the following semester will be placed on academic probation:

Academic Suspension: Students who are on academic warning or academic probation and fail to increase their cumulative and semester GPA to a 2.0 or higher will be placed on academic suspension and will not be permitted to return to Victoria College until one long semester (fall or spring) has elapsed.

Academic Term: A length of time in which a course is taught. Academic terms can vary in length (e.g. 2 weeks, 5 weeks, 8 weeks, or 16 weeks). Students may register for several different academic terms within one semester.

Academic Warning: Students are placed on academic warning when their cumulative GPA drops below 2.0 after being on good standing.

Admission: The process of filling out forms, filing documents, and taking tests prior to registering for classes.

Admissions: The process of applying for entrance to Victoria College for undergraduate studies or vocational training.

Assessment: A test used to determine a student's skill levels in English, language arts, and reading (ELAR) and mathematics. The results are used to ensure that students are meeting basic skills before enrolling in college-level courses.

Catalog: A document published annually which includes policies and procedures, courses of study, degrees and certificates offered, admission and enrollment procedures, financial aid, student life and activities, and a variety of other information students need to know.

College: When capitalized, the term "College" means Victoria College.

College Official: Includes any person employed by Victoria College while performing assigned administrative or professional responsibilities.

College Premises: Includes all land, buildings, facilities, and other property that is owned, used, or controlled by the College.

Course: The organized subject matter in which instruction is offered within a given period of time. Courses can either be for credit or can be designated as noncredit.

Course Prerequisite: The preliminary requirement that must be met before a certain course can be taken.

Credit Hours: Courses taken in college are measured in terms of credit hours. To earn credit hours, a student must attend a class for one classroom hour (usually 50 minutes) per week for the whole semester (usually 16 weeks).

Curriculum: A group of required courses leading to a degree or certificate; also refers to course offerings of a college as a whole.

Elective: A subject or course which a student may choose to take rather than a course which is required.

Enrollment: The procedure by which students choose classes each semester. It also includes the assessment and collection of fees.

Full-Time Student: A student who takes 12 or more credit hours during a semester.

Grade Point Average: Determined by dividing the total grade points earned by hours attempted. Credit hours for a course in which a grade of W, S, SA, SB, SC, Q, U, or UF is earned will not be counted as hours attempted for the purpose of cumulative GPA calculation.

Hold: Refers to the indicator placed on a student's official record, preventing registration and/or issuance of a transcript until the student meets the requirements of the College office placing the indicator on the account.

Learning Assistance: Free services which provide additional academic assistance for all students.

Major: The specific subject area in which a student determines to devote the most effort in college; 24-30 semester hours of work in a specific subject area usually required. Half or more of these courses usually are in the junior and senior year at a four-year college or university.

Member of the College Community: Includes any person who is a student, visitor, faculty, staff member, College official, or any other person employed by the College.

Minor: A student's secondary subject choice. It usually consists of 18 or more semester hours in a specific subject area.

Noncredit Courses: Courses that are for students wanting to learn a new skill for career training, upgrade or recertify existing skills, gain general knowledge, or develop personal interests. Upon completion, students receive a Victoria College Certificate of Completion. Students are not required to apply for admission to the College or take entrance exams for noncredit courses. No college credit is granted for these courses.

ORD (Official Reporting Date): The twelfth class day of a 16-week term, the sixth class day of an 8-week term, and the fourth class day of a 5-week term. Classes of varying lengths are prorated accordingly (See page 39).

Part-Time Student: A student who takes 11 or fewer hours during a semester.

Payment Plan: A method available to pay tuition and fees. To secure enrollment students must either enroll in a payment plan or pay in full by the time classes begin. Two options are available during the fall and spring semesters: the first requires one half of the tuition and fees paid at the time of registration, while the second requires paying one third of the tuition and fees paid at the time of registration. The remaining balance for each plan is due in two payments. For summer, the balance is due in one payment. During certain early registration periods, the College will offer a payment plan that requires one fourth down and three payments. There is a \$20 service fee to use the payment plan.

Pirate Portal: A secure, personalized gateway where VC students can access important College information, check email, access online courses, register for courses, check grades, and more.

Prerequisite: A defined set of criteria that must be met to enter a program or take a course.

Registration: The process where students sign up or enroll in applicable courses towards their academic pursuits.

Satisfactory Academic Progress (SAP): Used to define successful completion of coursework to maintain eligibility for student financial aid. Students must maintain established minimum standards in the areas of GPA, completion rate, and maximum time frame to be eligible for Federal Title IV funds (any of the federal student aid funds).

TERMS TO KNOW

Semester: An academic term within the academic school year typically lasting 16 weeks or the combination of both summer sessions typically lasting 10 weeks collectively.

Schedule of Classes: Designated courses offered each semester which includes classes by department, course number, class days and times, building names and room numbers, and the instructors' names.

Student: Any person taking any credit or noncredit course(s) offered by the College.

Support Services: A collection of comprehensive nonacademic student support services such as the food and clothing pantry, transportation assistance, and various counseling services.

Syllabus: An outline of the important information about a course. Written by the instructor, it usually includes important dates, assignments, expectations, and policies specific to that course.

Texas Core Curriculum: Passed by the Texas Legislature in 1987, the Texas Core Curriculum is a 42-semester-credit-hour curriculum for all undergraduate students in Texas. The elements include six core objectives and nine common component areas.

Texas Success Initiative Assessment (TSIA): A Texas-legislated assessment in English language arts and reading (ELAR) and mathematics used to place students into appropriate entry-level coursework.

Transcript: A student's academic record.

Transfer Course: Any course offered that is listed in *The Community College General Academic Course Guide Manual*.

Transfer Institution: A college or university to which one may transfer for advanced education or training after attending a community college.

Tuition & Fees: Charges levied for enrolling in classes and for the use of College facilities. See the College catalog and/or semester schedule for additional information.

Important Dates & Numbers

(This page left blank intentionally)

Contact Numbers

Victoria College Main Campus

(361) 573-3291
Toll Free (877) 843-4369

Gonzales Center (830) 672-6251

Administrative Offices

Welcome Center (361) 485-6841

Advising & Counseling Services	(361) 582-2400
Adult Education	(361) 573-7323
Admissions & Records	(361) 485-6841
Academy of Lifelong Learning	(361) 582-2520
Allied Health Continuing Education	(361) 582-2412
Bookstore	(361) 572-6430
Cafe Espresso	(361) 582-2460
Childcare Assistance	(361) 572-6415
Computer Help Desk	(361) 582-2509
The Cove & Subway Restaurant	(361) 582-2477
Emerging Technology Complex	(361) 580-3700
Enrollment Services.....	(361) 582-2400
Financial Aid	(361) 572-6415
The Grind	(361) 485-6820
Human Resources	(361) 582-2459
Institutional Effectiveness and Learning Technologies	(361) 485-6842
KEY Center – Student Support Services	(361) 582-2414
Leo J. Welder Center for the Performing Arts	(361) 485-8540
Learning Lab	(361) 572-6473
Library	(361) 485-6853
Museum of the Coastal Bend	(361) 582-2511
Payments	(361) 485-6840
Police & Campus Safety	(361) 582-2406
Sports Center	(361) 573-3291
Student Life	(361) 485-6838
Success Coaching.....	(361) 582-2438
Testing Center	(361) 582-2589
VC Foundation	(361) 582-2518
Veterans Services	(361) 572-6462
Workforce & Continuing Education	(361) 582-2528

Academic Divisions

Division of Academic Support & Student Success	(361) 582-2438
Division of Allied Health	(361) 582-2570
Division of Arts, Humanities, & Social Sciences	(361) 582-2530
Division of Career & Technical Education	(361) 572-6467
Division of Science, Mathematics, Engineering, & Physical Education.....	(361) 485-6824

Business & Technology

Business Management	(361) 582-2579
Network Engineering Technology & Cloud Computing.....	(361) 572-6478
Real Estate	(361) 582-2528

Health Careers

Electrocardiogram (EKG) Technician.....	(361) 582-2412
EMS Training	(361) 582-2412
Medical Assisting	(361) 582-2412

Medical Coding	(361) 582-2412
Medication Aide	(361) 582-2412
Mental Health Technician.....	(361) 582-2412
Nurse Aide	(361) 582-2412
Nursing-Associate Degree	(361) 572-6435
Nursing-Vocational	(361) 582-2545
Pharmacy Technician	(361) 582-2412
Phlebotomy	(361) 582-2412
Physical Therapist Assistant	(361) 572-6458
Respiratory Care	(361) 572-6426
Veterinary Assistant	(361) 582-2412

Industrial Trades

Automotive Service Excellence (ASE) Certification Testing	(361) 582-2528
Carpentry	(361) 582-2528
Construction Site Safety Technician (CSST)	(361) 582-2528
Electrical	(361) 582-2528
Electronics Technology	(361) 582-2506
Fiber Optics Training	(361) 582-2528
Heating, Ventilation & Air Conditioning	(361) 582-2528
Instrumentation	(361) 582-2506
Millwright	(361) 582-2528
NCCER Core Curriculum: Introductory Craft Skills.....	(361) 582-2528
Pipefitting	(361) 582-2528
Plumbing	(361) 582-2528
Power Line Worker	(361) 582-2528
Process Technology	(361) 582-2568
Scaffolding.....	(361) 582-2528
Truck Driving	(361) 485-6830
Warehouse Vehicle Operations	(361) 582-2528
Welding (Credit).....	(361) 572-6471
Welding (Noncredit).....	(361) 582-2528

Public Service

Criminal Justice	(361) 572-6426
Emergency Medical Services	(361) 572-6426
Law Enforcement	(361) 572-6426

Deaf, hard-of-hearing, and speech-impaired TDD users may call 1 (800) RELAYTX to utilize Relay Texas services.

Year at a Glance

Victoria College Academic Calendar, 2024-2025

August 2024							September 2024							October 2024						
Su	M	Tu	W	Th	F	Sa	Su	M	Tu	W	Th	F	Sa	Su	M	Tu	W	Th	F	Sa
				1	2	3	1	2	3	4	5	6	7			1	2	3	4	5
4	5	6	7	8	9	10	8	9	10	11	12	13	14	6	7	8	9	10	11	12
11	12	13	14	15	16	17	15	16	17	18	19	20	21	13	14	15	16	17	18	19
18	19	20	21	22	23	24	22	23	24	25	26	27	28	20	21	22	23	24	25	26
25	26	27	28	29	30	31	29	30						27	28	29	30	31		

November 2024							December 2024							January 2025						
Su	M	Tu	W	Th	F	Sa	Su	M	Tu	W	Th	F	Sa	Su	M	Tu	W	Th	F	Sa
					1	2	1	2	3	4	5	6	7				1	2	3	4
3	4	5	6	7	8	9	8	9	10	11	12	13	14	5	6	7	8	9	10	11
10	11	12	13	14	15	16	15	16	17	18	19	20	21	12	13	14	15	16	17	18
17	18	19	20	21	22	23	22	23	24	25	26	27	28	19	20	21	22	23	24	25
24	25	26	27	28	29	30	29	30	31					26	27	28	29	30	31	

February 2025							March 2025							April 2025						
Su	M	Tu	W	Th	F	Sa	Su	M	Tu	W	Th	F	Sa	Su	M	Tu	W	Th	F	Sa
						1						1			1	2	3	4	5	
2	3	4	5	6	7	8	2	3	4	5	6	7	8	6	7	8	9	10	11	12
9	10	11	12	13	14	15	9	10	11	12	13	14	15	13	14	15	16	17	18	19
16	17	18	19	20	21	22	16	17	18	19	20	21	22	20	21	22	23	24	25	26
23	24	25	26	27	28		23	24	25	26	27	28	29	27	28	29	30			
							30	31												

May 2025							June 2025							July 2025						
Su	M	Tu	W	Th	F	Sa	Su	M	Tu	W	Th	F	Sa	Su	M	Tu	W	Th	F	Sa
				1	2	3	1	2	3	4	5	6	7			1	2	3	4	5
4	5	6	7	8	9	10	8	9	10	11	12	13	14	6	7	8	9	10	11	12
11	12	13	14	15	16	17	15	16	17	18	19	20	21	13	14	15	16	17	18	19
18	19	20	21	22	23	24	22	23	24	25	26	27	28	20	21	22	23	24	25	26
25	26	27	28	29	30	31	29	30						27	28	29	30	31	1	2
														3	4	5	6	7	8	9

IMPORTANT NUMBERS AND DATES

VC Holidays (College Closed)

Labor Day	Sept. 2
Fall Break	Nov. 24-30
Winter Break	Dec. 22-Jan. 3
Martin Luther King, Jr. Day	Jan. 20
Spring Break	March 16-22
Good Friday	April 18
Memorial Day	May 26
Juneteenth	June 19
Independence Day	July 4
Commencement 2025	May 17
Fall 2024	
Fall Convocation	Aug. 23
Last Week of Registration	Aug. 19-22
Classes Begin	Aug. 26
Schedule Changes	Aug. 26-27
Official Reporting Date	Sept. 11
Mid-Semester	Oct. 18
Last Day to Drop	Nov. 6
Final Exams	Dec. 16-19
End of Semester	Dec. 20
Winter Interim	Dec. 23-Jan. 8
Spring 2025	
Administrative Offices Open	Jan. 6
Spring Convocation	Jan. 17
Last Week of Registration	Jan. 13-16
Classes Begin	Jan. 21
Schedule Changes	Jan. 21-22
Official Reporting Date	Feb. 5
Mid-Semester	March 14
Last Day to Drop	April 8
Final Exams	May 12-15
End of Semester	May 16
Summer 2025 Hours	
College Closed on Fridays	

	Start	ORD	Drop Deadline	Finals
Fall - Term Dates				
16 Week	Aug. 26	Sept. 11	Nov. 6	Dec. 16-19
15 Week	Aug. 26	Sept. 10	Nov. 6	Dec. 11-13
14 Week	Sept. 9	Sept. 20	Nov. 11	Dec. 16-19
12 Week	Sept. 3	Sept. 13	Nov. 25	Nov. 20-22
1st 4 Week	Aug. 26	Aug. 28	Sept. 12	Sept. 19-20
2nd 4 Week	Sept. 23	Sept. 25	Oct. 9	Oct. 17-18
3rd 4 Week	Oct. 21	Oct. 23	Nov. 6	Nov. 14-15
4th 4 Week	Nov. 18	Nov. 20	Dec. 11	Dec. 18-19
1st 8 Week	Aug. 26	Sept. 3	Oct. 1	Oct. 16-18
2nd 8 Week	Oct. 21	Oct. 28	Dec. 2	Dec. 16-19
	Start	ORD	Drop Deadline	Finals
Winter Interim - Term Dates				
Winter Interim	Dec. 23	Dec. 24	Jan. 3	Jan. 8
	Start	ORD	Drop Deadline	Finals
Spring - Term Dates				
16 Week	Jan. 21	Feb. 5	April 8	May 12-15
15 Week	Jan. 21	Feb. 4	April 8	May 7-9
14 Week	Feb. 3	Feb. 14	April 11	May 12-15
12 Week	Jan. 27	Feb. 6	March 27	April 23-25
1st 4 Week	Jan. 21	Jan. 23	Feb. 6	Feb. 13-14
2nd 4 Week	Feb. 17	Feb. 19	March 5	March 13-14
3rd 4 Week	March 24	March 26	April 9	April 16-17
4th 4 Week	April 21	April 23	May 7	May 14-15
1st 8 Week	Jan. 21	Jan. 28	Feb. 25	March 12-14
2nd 8 Week	March 24	March 31	April 29	May 12-15
	Start	ORD	Drop Deadline	Finals
Summer - Term Dates				
May Interim	May 19	May 20	May 29	June 3
1st 5 Week	June 5	June 10	June 25	July 7-8
8 Week	June 4	June 12	July 8	July 23-24
2nd 5 Week	July 10	July 15	July 29	Aug. 6-7
Last Revision: 6/5/2024				

(This page left blank intentionally)

Admissions & Academic Regulations

How to Apply for Admission

(for programs and courses leading to college credit)	1	2	3
	Dual Credit & Early Admission Students	First-Time Freshmen	Former VC Students
1. Complete VC application	✓	✓	If it has been more than one year since you enrolled
2. Have high school transcripts/GED sent to the Admissions & Records Office at Victoria College	✓	✓	Not Applicable
3. Provide Bacterial Meningitis immunization record (see page 21 to determine applicability)	If Applicable	If Applicable	If Applicable
4. Take the Texas Success Initiative (TSI) Assessment 2.0 (TSIA2) or submit exemption documentation (see page 19)	✓	✓	✓
5. Attend Pirate Orientation (required for students who have not earned college credit)	✓	✓	Not Applicable
6. Submit a Transient Approval Form	Not Applicable	Not Applicable	Not Applicable
7. Complete SaVE Act Training	Not Applicable	✓	Not Applicable
8. Attend a required dual enrollment information session with a parent or guardian	✓	Not Applicable	Not Applicable
9. Submit a Dual Credit or Dual Enrollment Form	✓	Not Applicable	Not Applicable
9. Submit an Authorization for Class Audit Form	Not Applicable	Not Applicable	Not Applicable

Admissions & Records Office

All admission documents should be sent to:

Victoria College • Admissions & Records Office • 2200 E. Red River Street • Victoria, TX 77901

How to Apply for Admission

4	5	6	7	8
Transfer Students	Transient Students	International F-1 Students (see pages 18 & 19)	Individual Approval Students	Audit Students
✓	✓	✓	✓	✓
✓ (Transfer students with fewer than 12 credit hours must also provide an official high school transcript or GED.)	Not Applicable	Must be evaluated by accredited evaluation service	Not Applicable	Not Applicable
If Applicable	If Applicable	If Applicable	If Applicable	If Applicable
✓	Indicated on Transient Approval Form	✓	✓	✓
Not Applicable	Not Applicable	✓	✓	Not Applicable
Not Applicable	✓	Not Applicable	Not Applicable	Not Applicable
✓	Not Applicable	✓	✓	Not Applicable
Not Applicable	Not Applicable	Not Applicable	Not Applicable	Not Applicable
Not Applicable	Not Applicable	Not Applicable	Not Applicable	Not Applicable
Not Applicable	Not Applicable	Not Applicable	Not Applicable	✓

For more information call (361) 485-6841 or email Admissions@VictoriaCollege.edu.

Application for Admissions

Prospective students apply for admission to Victoria College (VC) by completing an online application at GoApplyTexas.org. Applications are active for one year from the date submitted. If the applicant does not attend within one year of submitting an application, a new application is required. Admission to Victoria College does not guarantee admission to specific courses or programs. Admission requirements for certain programs differ from general admission requirements. Students should refer to the specific allied health or career and technical degree plan for selective admission requirements.

Methods of Admission

High School Graduates	Graduates from an accredited high school must have an official copy of their school transcript showing a graduation date on file with the Admissions & Records Office.
Home School Graduates	Graduates from an accredited high school must have an official copy of their school transcript showing a graduation date on file with the Admissions & Records Office.
GED	Applicants who successfully complete the General Education Development (GED) Test and receive the Certificate of High School Equivalency must have their Certificate of Equivalency on file with the Admissions & Records Office.
Nonaccredited High School Graduates	Graduates from a nonaccredited high school must submit an official copy of their high school transcript showing a graduation date. Graduates from a nonaccredited high school must also submit an Individual Approval Form and comply with institutional testing requirements.
Dual Credit/Early Admission	Early admission enrollment students must submit an application to Victoria College and schedule an appointment with a College Recruitment Specialist for information on additional required documents. To schedule an appointment, contact VC's Enrollment Services Office at (361) 582-2400.
Transfer Students	Students who have attended another college must present an official transcript from each college attended as well as assessment scores (for students who are not assessment exempt). An official high school transcript or GED certificate is also required for transfer students who have earned less than 12 hours of credit. The record of work done at another institution will be evaluated according to the minimum standards in effect. All admission documents should be sent to the Admissions & Records Office prior to registration. For transfer credit information, see Transfer Credit Policy on page 42.
Transient Students	Students may enroll in a maximum of 14 credit hours per semester at Victoria College with the approval of their home institution. Students are required to submit required immunization records, an application to Victoria College via GoApplyTexas.org , and a completed Victoria College Transient Approval Form signed by the student's home institution's registrar/designee.
Foreign Students	Victoria College recognizes three categories of noncitizen students. Specific admission requirements apply to students who are not U.S. citizens (see page 19).
Individual Approval	Applicants not meeting the requirements for admissions listed above will be required to provide evidence they can complete college-level work. An Individual Approval Form (www.VictoriaCollege.edu/AdmissionsRecords) must be completed, and the Registrar will determine eligibility for admittance to Victoria College.

Foreign Student Admission Requirements

1. Permanent Residents: Submit a copy of your permanent residence card and green card, and then meet the same admission requirements as a U.S. citizen.
2. Refugee: Submit a copy of form I-94 indicating refugee status and then meet the same admission requirements as a U.S. citizen.
3. F-1 Visa students: The following requirements apply to all applicants holding a nonimmigrant visa issued by the U.S. Bureau of Citizenship and Immigration Service (USCIS):
 - Completed Application for Admission
 - Completed Application for I-20*
 - High School Transcripts – Translated and evaluated by an approved Evaluation Service*
 - Approved transfer credit from an international university will be applied towards elective credit hours at Victoria College.
 - Official TOEFL Score Report with minimum score requirement of 500 for paper version; 173 for computer-based version; 71 for internet-based version (www.toeflgoanywhere.org)
 - Official IELTS score with minimal score requirement of 6.
 - Financial documents – Statement of Financial Support and/or bank statement(s)/bank letter showing U.S. equivalency
 - Texas Success Initiative (TSI) Assessment Exam (THEA, Compass, Accuplacer, Asset, etc.).
4. Requirements for students transferring from another U.S. college or university:
 - Official transcript from transfer school, copy of I-20 from that advisor's report, and Form I-94

*The I-20 will not be processed until all of the above requirements have been met. Requests for I-20s should be made at least 60 days prior to the semester in which the student plans to enroll. Once the I-20 has been issued, the prospective student must also complete an I-901 form and submit it with the appropriate fee via internet, telephone, or mail to USCIS.

*Victoria College accepts foreign transcripts evaluated by an approved evaluation service. The current list of approved evaluation services can be located at: www.VictoriaCollege.edu/InternationalStudents

Conditional Admission

Students who submit an application to the College must meet the requirements described in the Methods of Admission sections (page 18). Students (excluding International F-1 Students) will be accepted and admitted conditionally for one semester.

Students have until the Official Reporting Date (ORD) of the first semester to submit all required documentation. Students who do not provide the required documentation will have an administrative hold placed on their accounts and will not be allowed to re-enroll or obtain a copy of their transcript until all documents are received.

Transcripts

Transcripts must bear the institution's seal, date, appropriate signature, and arrive at the Admissions & Records Office in their original sealed envelope to be considered official. All transcripts delivered electronically directly to Victoria College via a secure transcript delivery system are considered official. Transcripts that indicate coursework in progress will not satisfy the requirement for an official transcript.

If there are questions on the validity of a student's high school transcript, the Admissions and Records Office will do the following:

1. Check with the high school to confirm the validity of the student's diploma
2. Confirm with the state agency in which the high school is located that the school is recognized as a valid high school

Admission Review Policy for Disciplinary Notation

If any applicant submits to Victoria College a transcript with a disciplinary notation (suspension or expulsion), the Admissions & Records Office will send written notification to the Vice President of Student Services to review the disciplinary action. In addition, an independent review will be required to assess the academic readiness of the application. After the reviews are complete, the applicant will receive a written admission decision.

Submitted Documents

Students are responsible for submitting the required documents to the Admissions & Records Office. All documents submitted become the property of Victoria College and cannot be returned to the student. Students who need copies of submitted documents should contact the issuing institution, agency, etc. directly. This includes college and high school transcripts, GED records, immunization records, etc.

Admission to College

Equal Educational Opportunity

Victoria College does not discriminate on the basis of race, color, religion, national origin, gender, pregnancy, age, disability, genetic information, marital status, amnesty, veterans status, or limited English proficiency. It is our policy to comply fully with the nondiscrimination provision of all state and federal rules and regulations.

Official Communication

All official communication to students from Victoria College will be sent to students' VC Pirate Portal email. Students will receive their login credentials for the VC Pirate Portal in an email to the personal email address that was supplied on the application once the application has been processed by the Admissions & Records Office.

Required State Testing

Texas Success Initiative (TSI)

Texas Administrative Code Title 19, Part 1, Chapter 4, Subchapter C requires that all students entering Texas public institutions of higher education are assessed by a state-approved test in the areas of reading, math, and writing to ensure that basic skills are met before enrolling in entry-level freshman coursework. This includes all full-time and part-time students. Performance on the test will not be used as a condition of admission. Scores from the TSI Assessment are valid five 5 years from the date of testing.

Undergraduate students who enter without an exemption are required to take the Texas Success Initiative Assessment 2.0 (TSIA2).

Assessment Test for TSI Completion:

The Texas Higher Education Coordinating Board (THECB) has established the TSI Assessment as the sole instrument for measuring TSI completion. THECB has determined the following scores for determining college readiness.

TSI Assessment (Before Jan. 11, 2021):

TSI Assessment Minimum Passing Scores		5- year limit
Math Minimum Score:	350	
Reading Minimum Score:	351	
Writing Minimum Score:	At least a 340 and an essay score of at least a 4 OR less than 340 and an ABE Diagnostic at least 4 and an essay score of at least a 5	

TSI Assessment 2.0 (TSIA2) (Beginning Jan. 11, 2021 and after):

TSI Assessment 2.0 (TSIA2) Minimum Passing Scores		5- year limit
Math Minimum Score:	Test Score ≥ 950; Test Score < 950 and Diagnostic Level = 6	
English Language Arts & Reading Score:	Test Score ≥ 945 and Essay ≥ 5; Test Score < 945 and Diagnostic Level ≥ 5 and Essay ≥ 5	

TSI Completion:

TSI completion is achieved by one or more of the following conditions:

- Meeting minimum standards in reading, math, and writing on the TSI Assessment or the English language arts and reading (ELAR) and mathematics on the TSIA2.
- Earning an SA, SB, or SC in the appropriate-level developmental education course for area(s) not meeting minimum standards on an assessment test
- Other institutional criteria – Students who entered Victoria College in Spring 2004 and after who were assessed and earned college credit prior to Fall 1989 will be required to contact Advising & Counseling Services to receive individual determination concerning assessment and placement. TASP exemptions made prior to Spring 2004 for students who earned three hours or more before Fall 1989 will be honored.
- Producing evidence of an established exemption (see exemptions below)

See page 183 for exemption revisions.

Exemptions:

a. The following students shall be exempt from the requirements of this title:

- (1) Standardized test scores

ACT	ACT taken before February 15, 2023 Composite score 23: with a minimum of 19 on the English test	5-year limit
	Composite score 23: with minimum of 19 on the mathematics test	
	ACT taken after February 15, 2023 Combined score of 40 on English & Reading (E+R) tests Mathematics minimum score of 22	
SAT	SAT taken before March 2016 Combined critical reading and math score of 1070 with a minimum of 500 on the critical reading test Combined critical reading and math score of 1070 with a minimum of 500 on the math test	5-year limit
	SAT taken March 2016 and after Evidence-based reading and writing minimum score of 480 Mathematics minimum score of 530	
STAAR	Minimum score of 4000 on the English III test	5-year limit
	Minimum score of 4000 on the Algebra II test	
11th Grade Exit Level TAKS	Minimum score of 2200 on the math section	5-year limit
	Minimum score of 2200 on the English language-arts section with a writing subsection score of at least a 3	

(2) A student who has graduated with an associate or baccalaureate degree from an institution of higher education

(3) A student who transfers to an institution from a private or independent institution of higher education or an accredited out-of-state institution of higher education and who has satisfactorily completed college-level coursework as determined by the receiving institution

(4) A student who has previously attended any institution and has been determined to have met readiness standards by that institution

(5) A student who is enrolled in a certificate program of one year or less (Level 1 Certificates) at a public junior college, a public technical institute, or a public state college

(6) A student who is serving on active duty as a member of the armed

forces of the United States, the Texas National Guard, or as a member of a reserve component of the armed forces of the United States and has been serving for at least three years preceding enrollment

(7) A student who on or after August 1, 1990, was honorably discharged, retired, or released from active duty as a member of the armed forces of the United States or the Texas National Guard or service as a member of a reserve component of the armed forces of the United States

b. An institution may exempt a non-degree-seeking or non-certificate-seeking student.

c. Any student who has been determined to be exempt in mathematics, reading, and/or writing under subsection (a) or (b) of this section shall not be required to enroll in developmental coursework and/or interventions in the corresponding area of exemption.

d. A student who successfully completes a college preparatory course (makes at least a 70 on the final exam) is exempt for a period of 24 months from the date of high school graduation with respect to the content area of the course. The student must enroll in the student's first college-level course in the exempted content area in the student's first year of enrollment. ~~This exemption applies only at Victoria College.~~

Dual Credit Exemptions:

The following students shall be exempt from the requirements of this title:

Standardized test scores

PSAT (NMSQT)	PSAT taken October 2015 and after: Evidence-based reading and writing minimum score of 460 Mathematics minimum score of 510	No longer valid once student graduates from high school
STAAR (waiver)	Minimum score of 4000 on the English II test	No longer valid once student graduates from high school
	Minimum score of 4000 on the Algebra I test and 70 or above in the Algebra II class	
PLAN	Composite score of 23 with a minimum of 19 on the English test	No longer valid once student graduates from high school
	Composite score of 23 with a minimum score of 19 on the mathematics test	
ACT-Aspire	Minimum score of 435 on the English test	No longer valid once student graduates from high school
	Minimum score of 431 on the mathematics test	
ACT	ACT taken before February 15, 2023 Composite Score: 23 with a minimum of 19 on the English test	5-year limit
	Composite Score: 23 with a minimum of 19 on the mathematics test	
	ACT taken after February 15, 2023 Combined score of 40 on English & Reading (E+R) tests Mathematics minimum score of 22	
SAT	SAT taken before March 2016 Combined critical reading and math score of 1070 with a minimum of 500 on critical reading test	5-year limit
	Combined critical reading and math score of 1070 with a minimum of 500 on math test	
	SAT taken March 2016 and after Evidence-based reading and writing minimum score of 480 Mathematics minimum score of 530	

Immunizations

Bacterial Meningitis (Senate Bill 1107)

Effective January 1, 2012

During the 82nd Texas Legislative session, Senate Bill 1107 was passed. This bill requires all **new students, transfer students, and returning students** who have had a fall or spring semester break in their attendance at an institution of higher education to provide proof of bacterial meningitis vaccination (or a booster dose). The bacterial meningitis vaccination must have been given during the **preceding five-year time period and at least 10 days prior to the first day** of the semester. A student will not be able to register for classes without providing proof of the bacterial meningitis vaccine.

1. This bill applies to:

- a. New students: A first-time student of an institution of higher education or private or independent institution of higher education, including a student who transfers to the institution from another institution
- b. Returning students: A student who previously attended an institution of higher education or private or independent institution of higher education before January 1, 2012, and who is enrolling in the same or another institution of higher education or private or independent institution of higher education following a break in enrollment of at least one fall or spring semester

2. Evidence of Vaccination - Acceptable evidence of vaccination or receiving a booster dose includes:

- a. the signature or stamp of a physician or his/her designee or public health personnel on a form which shows the month, day, and year the vaccination dose or booster was administered; or
- b. an official immunization record generated from a state or local health authority; or
- c. an official record received from school officials, including a record from another state.

Exceptions

a. A student is not required to submit evidence of receiving the vaccination against bacterial meningitis or evidence of receiving a booster dose if:

1. the student is 22 years of age or older by the first day of the start of the semester in which they will be attending classes; or
2. the student is enrolled only in online or other distance education courses and is not required to attend any course meetings, including final exams, on campus; or
3. the student is enrolled in a continuing education course or program that is less than 360 contact hours, or workforce & continuing education corporate training; or
4. the student is enrolled in a dual-credit course which is taught at a public or private K-12 facility not located on a higher education institution campus; or
5. the student is incarcerated in a Texas prison.

b. A student, or a parent or guardian of a student, is not required to submit evidence of receiving the vaccination against bacterial meningitis if the student, or a parent or guardian of a student, submits to the institution:

1. an affidavit or a certificate signed by a physician who is duly registered and licensed to practice medicine in the United States, in which it is stated that, in the physician's opinion, the vaccination required would be injurious to the health and well-being of the student; or
2. an affidavit signed by the student stating that the student declines the vaccination for bacterial meningitis for reasons of conscience, including a religious belief.

Residency Requirements

Each student must show proof of both Texas and Victoria College District residency in order to pay resident and in-district tuition and fees. If, after submitting an application to Victoria College, there remain questions as to the student's proper residency classification, the student must provide a copy of one or more appropriately dated documents which will establish Texas or in-district residency.

The student is responsible for enrolling under the proper residency classification and for providing documentation as required by the institution. If there is any question about classification as a resident of Texas, the student must seek clarification from the Admissions & Records Office.

Students classified as nonresidents or out-of-district upon first enrollment at Victoria College are presumed to be nonresidents or out-of-district for the period during which they continue as students. Students who believe they are eligible for residency reclassification must submit a Request for Change of Residency Status Form (www.VictoriaCollege.edu/AdmissionsRecords).

Appropriate documentation should be submitted to the Admissions & Records Office and meet the requirements for reclassification. This request must be submitted prior to the official reporting date of the term in order to have the request considered for that term.

Determining State Residency

The rules for determining state residency are:

- Individuals 18 years of age or older who lived in Texas 12 months before enrolling are entitled to classification as a resident.
- For dependents over 18, state residency is determined by the parent who claims the student for federal income tax purposes both at the time of enrollment and for the tax year preceding enrollment.
- Persons classified as nonresident students upon first enrollment are presumed to be nonresident for the period during which they continue as students.
- Students enrolling before having resided in the state for 12 months immediately preceding time of enrollment are classified as nonresidents for tuition purposes.

The following are some of the documents that can be used to provide evidence of Texas residency:

1. A transcript showing graduation from a Texas high school within the 12 months before enrollment
2. A permanent Texas driver's license issued at least 12 months prior to the time of enrollment
3. A W-2 form or pay statement showing employment in Texas at least 12 months preceding enrollment
4. A purchase of a homestead at least 12 months preceding enrollment
5. A voter registration card issued at least 12 months prior to the time of enrollment

Determining In-District Residency

Once students have met the state residency requirements, they can verify their in-county (Victoria County) residency of at least six months by presenting one or more of the following types of documentation.

This documentation must show an in-district address for the six months immediately prior to enrollment:

1. A permanent Texas driver's license with current address
2. A lease agreement which includes the student's name
3. A utility bill
4. A voter registration card
5. A payroll check stub
6. A property tax statement showing payment of Victoria College district taxes
7. A notarized statement which includes the student's name and address (from a third party)

The Board of Trustees of Victoria College authorizes the waiver of the difference in the rate of tuition for the out-of-county or nonresident and in-county student or his/her dependent(s), who owns property purchased by or before time of enrollment which is subject to ad valorem taxation by the Victoria County Junior College District. The individual, or his/her dependents, applying for such waiver shall verify property ownership by

presentation of an ad valorem tax statement or receipt, issued by the tax office of the district; or by presentation of a deed, property closing statement, or other appropriate evidence of ownership of property which is subject to ad valorem taxation by the district. This must be done prior to registration.

Military Personnel & Dependents

Persons in military service are presumed to maintain during their entire period of active service the same legal residence which was in effect at the time of entering the service. Education Code 54.058(b) provides that military personnel assigned to duty within the state of Texas, their spouses, and their dependent children, shall be entitled to pay the same tuition as a resident of Texas regardless of the length of their physical presence in the state. To be entitled to pay resident tuition, military personnel shall submit at initial time of enrollment a statement from their commanding officer regarding their military status. This statement also must be obtained if active duty members seek resident tuition for their spouses or dependents. This statement is valid for one academic year. Each fall semester begins a new academic year at which time another form must be submitted.

Academic Fresh Start

An applicant for admission who is a Texas resident may seek to enter Victoria College pursuant to the Academic Fresh Start statute, Texas Education Code, 51.931. The applicant must complete the Academic Fresh Start Petition and submit it to the Admissions & Records Office prior to the first day of class of the returning semester. Under the provision of this statute, the institution will not consider academic course credits or grades earned by the applicant ten or more years prior to the starting date of the semester in which the applicant seeks to enroll. An applicant who makes the election to apply under this statute may not receive any course credit for courses taken ten or more years prior to enrollment. For more information, contact the Admissions & Records Office. Academic Fresh Start clears only the student's academic record. The Financial Aid Office must still count all prior credits earned when determining financial aid eligibility.

Requesting a Victoria College Transcript

Upon graduation, a student will receive two official transcripts at no charge. The cost for each additional transcript will be \$10.

To request an official transcript, visit the Welcome Center or complete an online request at www.VictoriaCollege.edu/TranscriptRequest.

Requests made through email, mail, or fax will not be accepted.

Students transferring to the University of Houston-Victoria (UHV) can fill out the Permission to Release Records to UHV form available at the Welcome Center or www.VictoriaCollege.edu/AdmissionsRecords. Transcripts sent using this method are free of charge.

Please note: Any student who has an administrative hold in the College's information system will not be able to view their unofficial transcript, receive refund checks, enroll for a consecutive semester, or receive transcripts.

Student Requirements

Pirate Orientation

Pirate Orientation is designed to familiarize students with resources that are key to their success and learn about their responsibilities as a VC student.

First time freshmen and dual credit students are required to participate in Pirate Orientation.

Pirate Orientation is online, and students will receive an email in their VC account with information on how to complete the virtual orientation.

If the student does not attend a Pirate Orientation session, a hold preventing future registrations will be added to the student account.

Campus SaVE Act

The Campus SaVE Act requires that higher education institutions to provide students with training that addresses on topics such as related to rape, acquaintance rape, domestic violence, dating violence, sexual assault, and stalking.

All entering first-time freshmen and transfer students are required to complete the **Campus SaVE Act training** online trainings in during their first and second semesters at Victoria College. The trainings will be sent to the students' VC Pirate Portal email from **Vector Solutions** the day after they register for classes and must be completed by the Official Reporting Date (ORD) of the **their first** semester. If the trainings are not completed by the ORD of the semester, then an administrative hold will be placed on the student's account.

Additional online trainings on topics such as alcohol and drug awareness, mental well-being, hazing awareness, health and safety awareness on campus, clarifying consent, active shooter preparedness, and study skills will also be sent to students. While these trainings are highly encouraged, they do not carry a hold if not completed.

First Semester Trainings	Second Semester Trainings
Campus SaVE Act	Active Shooter Preparedness
Hazing	Alcohol Awareness
Suicide Prevention	Drug Awareness & Abuse
Intimate Partner Violence for Students	Bystander Intervention

Learning Frameworks

All incoming freshmen with fewer than 13 hours are required to enroll in SDEV 0301. EDUC 1300 may be substituted for SDEV 0301.

Health Career Programs

Applicants for any health career or emergency medical services programs must meet special entrance requirements and complete a departmental application form, in addition to completing the general Victoria College application for admission and meeting general admission requirements.

ACT, SAT, or ATI TEAS exam scores may be required for admission. The Department of State Health Services and Victoria College require that these students receive adequate immunization prior to clinical learning experiences.

Texas Guided Pathways

The Texas Guided Pathways Model is a comprehensive approach to student success that provides each student an efficient and effective experience within Victoria College towards their academic and professional goals. Central to the pathways model are clear, educationally coherent program maps (Plan-of-Completion) that are aligned to what will be expected of students upon program completion in the workforce and in education at the next level in a given field. Students receive assistance with exploring academic and career options, selecting a program of study, and developing a plan-of-completion based on program maps. Victoria College requires that all entering freshmen meet with an Academic Advisor prior to their first registration. All students will be required to meet with their Academic Advisor after the successful completion of 15, 30, 45, and 60 credit hours before enrolling within their next semester.

Students' Right to Review Information

With a few exceptions, students have the right to request, receive, review, and correct information collected on the application for admission. Each semester, students participating in advisor-assisted registration and self registration have an opportunity to review, correct, and verify application information as part of the registration process. For more information regarding 20 USC 1232G – Family Educational Rights and Privacy Act, visit <https://www2.ed.gov/policy/gen/guid/fpco/ferpa/index.html>.

Curriculum

Field of Study Curriculum

The Field of Study Curriculum is a set of courses that will satisfy the lower-division academic requirements for a bachelor's degree in a specific academic area.

All public four-year/upper-level institutions are required to accept the Field of Study Curriculum in fulfillment of those lower-division courses required in majors that correspond to the field of study.

Approved Field of Study Curriculum is defined by the Texas Higher Education Coordinating Board. Information concerning approved Field of Study Curriculum can be found at www.thecb.state.tx.us.

Victoria College does not offer all field of study courses. More information is also available through Advising & Counseling Services.

General Education

As an institution of higher education, Victoria College embraces the philosophy that a well-educated person understands multiple perspectives about the individual and the world in which he or she lives; discusses and reflects upon individual, political, and social aspects of life so as to understand ways in which to exercise responsible citizenship; and integrates knowledge and understands the interrelationships of the disciplines.

Victoria College's Core Curriculum is designed to provide students with the general education expected of any well-educated person.

Core Curriculum

The Core Curriculum is a set of courses in the liberal arts, humanities, sciences, and political, social, and cultural histories that all undergraduates of an institution of higher education are required to complete before receiving a degree. **Completion of the core curriculum DOES NOT complete the requirements for an associates degree.** To fulfill the College's academic standards and to assist students in becoming well-rounded, educated individuals, students should complete the core curriculum, found on page 25.

If a student successfully completes the Core Curriculum at a Texas public institution of higher education, that block of courses may be transferred to any other institution of higher education and must be substituted for the receiving institution's Core Curriculum. A student shall receive academic credit for each of the courses transferred and may not be required to take additional Core Curriculum courses at the receiving institution unless the Texas Higher Education Coordinating Board has approved a larger core curriculum at that institution.

Full degree requirements can be found on pages 26-28.

A student who completes the Core Curriculum at Victoria College will have acquired the knowledge and skills necessary to gain a foundation of knowledge of human culture and the physical and natural world; develop principles of personal and social responsibility for living in a diverse world; and advance intellectual and practical skills that are essential for all learning.

Demonstrate critical thinking, including the ability to

- conduct an inquiry into a concept by close examination or analytical interpretation,
- examine explanations, evidence, and/or problem-solving methods,
- synthesize individual argument components into a meaningful, coherent whole, and
- create an artifact that uses evidence to form a coherent conclusion or by taking an innovative approach to a given task.

Communicate effectively, including the ability to

- produce an acceptable artifact for the intended audience and medium;
- produce an artifact with ordered ideas and in an appropriate format;
- develop the idea or content with relevant research, reasoning, and/or evidence, and
- utilize delivery conventions appropriate to the medium which may include:
 - punctuation, capitalization, spelling, documentation, and/or
 - posture, gesture, eye contact, and vocal expressiveness, or
 - animation, transitions, visual clarity, and images.

Utilize empirical and quantitative skills, including the ability to

- identify the information that is being sought and give evidence of analysis required using relevant sources,
- assimilate the information required for analysis in an organized manner,
- analyze the relevance or logic of the steps taken toward achieving the desired outcomes, and
- present the outcome of the analysis in which a clear conclusion is conveyed.

Demonstrate teamwork, including the ability to

- contribute to the completion of the given assignment through materials, effort, and/or leadership;
- cooperate with the group to finalize ideas and plans of actions while demonstrating a good attitude, sharing information, acknowledging a shared purpose, and problem-solving techniques; and
- manage him/herself in regard to work ethic, ability to meet deadlines, ability to prioritize projects, and ability to focus on the task at hand.

Demonstrate social responsibility, including the ability to

- compare and/or contrast cultures or groups, and
- demonstrate knowledge of civic responsibility that enables effective engagement in regional, national, and/or global communities.

Demonstrate personal responsibility, including the ability to

- examine the elements that constitute an ethical dilemma,
- identify and explain the actions taken by those individuals and/or societies facing an ethical dilemma, and
- recognize and/or predict the consequences that arise from an ethical dilemma.

ADMISSIONS & ACADEMIC REGULATIONS

The Foundational component areas of the core curriculum follow:

Communications focuses on developing ideas and expressing them clearly, considering the effect of the message, fostering understanding, and building the skills needed to communicate persuasively. Courses involve the command of oral, aural, written, and visual literacy skills that enable people to exchange messages appropriate to the subject, occasion, and audience.

1. Demonstrate writing or speaking processes.
2. Write or speak to an appropriate audience, for a specific purpose, and select appropriate communication choices.
3. Use appropriate evidence and reasoning to support claims.

Mathematics focuses on quantitative literacy in logic, patterns, and relationships. Courses involve the understanding of key mathematical concepts and the application of appropriate mathematical tools to the everyday experience.

1. Apply appropriate mathematical methods (e.g., arithmetic, algebraic, geometric, or statistical methods) to model and solve real-world situations; when appropriate, use technology.
2. Represent and evaluate basic mathematical information in written forms (e.g., numerically, graphically, or symbolically).
3. Use mathematical reasoning skills by interpreting mathematical models (e.g., formulas, graphs, tables, or illustrations) and draw inferences to develop convincing mathematical arguments.

Language, Philosophy, and Culture focuses on how ideas, values, beliefs, and other aspects of culture express and affect human experience. Courses involve the exploration of ideas that foster aesthetic and intellectual creation in order to understand the human condition across cultures.

1. Demonstrate awareness of the scope and variety of works in the humanities.
2. Evaluate those works as expressions of individual and human values within a historical and social context.
3. Respond critically to works in the humanities.

Creative Arts focuses on the appreciation and analysis of creative artifacts and works of the human imagination. Courses involve the synthesis and interpretation of artistic expression and enable critical, creative, and innovative communication about works of art.

1. Identify three period artistic styles.
2. Critically analyze two elements of works in the arts.
3. Identify terminology and principles that guide or govern the arts.

Life and Physical Sciences focuses on describing, explaining, and predicting natural phenomena using the scientific method. Courses involve the understanding of interactions among natural phenomena and the implications of scientific principles on human experience.

1. Understand and apply method and appropriate technology to the study of life and/or physical science.
2. Collect data, use the data in calculations, interpret the data, and be able to present conclusions based on the data analysis.
3. Understand the interdependence of science and technology and their influence on, and contribution to, modern culture.

Social/Behavioral Sciences focuses on the application of empirical and scientific methods that contribute to the understanding of what makes us human. Courses involve the exploration of behavior and interactions among individuals, groups, institutions, and events, examining their impact on society and culture.

1. Employ the appropriate methods, technologies, and/or data that social and behavioral scientists use to investigate the human condition.
2. Examine institutions and/or processes across a range of historical periods, social structures, or cultures.
3. Use and critique alternative explanatory systems or theories.

American History focuses on the consideration of past events relative to the United States, with the option of including Texas history for a portion of this component area. Courses involve the interaction among individuals, communities, states, the nation, and the world, considering how these interactions have contributed to the development of the United States and its global role.

1. Examine social institutions and processes across a range of historical periods.
2. Analyze the effects of historical and global forces on the area under study.
3. Assess and analyze historical evidence.

Government/Political Science focuses on consideration of the Constitution of the United States and the constitutions of the states with special emphasis on that of Texas. Courses involve the analysis of governmental institutions, political behavior, civic engagement, and their political and philosophical foundations.

1. Analyze the effects of historical, social, political, economic, cultural, and global forces on the area under study.
2. Comprehend the origins and evolution of the U.S. and/or Texas political systems, with a focus on the growth of political institutions, the constitutions of the U.S. and/or Texas, federalism, civil liberties, and civil and human rights.
3. Analyze, critically assess, and develop creative solutions to public policy problems.

Victoria College Core Curriculum Courses

Core Component	Core #	Course Selection		Minimum Hours Required
COMMUNICATION	010	Select 1	ENGL 1301, 2311	6
		Select 1	ENGL 1302, 2311	
MATHEMATICS	020	Select 1	MATH 1314, 1316, 1324, 1332, 1342, 2312, 2412, 2413	3*
LIFE AND PHYSICAL SCIENCES	030	Select 2	BIOL 1322, 1406, 1407, 1408, 1409, 2306, 2404, 2420; CHEM 1406, 1411, 1412; ENVR 1301, GEOL 1303, 1305, 1345, 1347, 1401, 1402, 1403, 1404; PHYS 1303, 1304, 1310, 1401, 1402, 2425, 2426	6* +*
LANGUAGE, PHILOSOPHY AND CULTURE	040	Select 1	ENGL 2322, 2323, 2327, 2328; HUMA 1301; PHIL 1301	3
CREATIVE ARTS	050	Select 1	ARTS 1301, 1303, 1304; DRAM 1310; MUSI 1306, 1307, 1310	3
AMERICAN HISTORY	060	Select 2	HIST 1301, 1302, 2301, 2327, 2328	6
GOVERNMENT/POLITICAL SCIENCE	070	Select 2	GOVT 2305, 2306	6
SOCIAL AND BEHAVIORAL SCIENCES	080	Select 1	ECON 2301, 2302; GEOG 1303; PSYC 2301; SOCI 1301	3
COMPONENT AREA OPTION	090	Select 6 SCH	Any course listed above except ENGL 1301, GOVT 2305, and GOVT 2306.	6
			BCIS 1305 (3) or COSC 1301 (3); EDUC 1300 (3); SPCH 1311 (3), 1315 (3), 1318 (3), or 1321 (3); MATH 1325 (3) *OTHER HOURS – BIOL, 1406 (1), 1407 (1), 1408 (1), 1409 (1), 2404 (1), 2420 (1); CHEM 1406 (1), 1411 (1), 1412 (1); GEOL 1401 (1), 1402 (1), 1403 (1), 1404 (1); MATH 2413 (1); PHYS 1401 (1), 1402 (1), 2425 (1), 2426 (1)	

* Additional hours fall to Component Area Option or will fulfill degree requirements.

+ Associate of Arts Interdisciplinary Studies Degree – completion of two science courses with at least one course being a lab science course (may be used to satisfy core requirements).

* Associate of Science Interdisciplinary Studies Degree – completion of two lab science courses (may be used to satisfy core requirements).

Degree/Certificate Requirements

Victoria College grants the following:

- Associate of Arts Interdisciplinary Studies Degree
- Associate of Science Interdisciplinary Studies Degree
- Associate of Applied Science Degree
- Certificates for selected Allied Health Programs and Career & Technical Education Programs

Multiple Degrees

Students may be awarded either the Associate of Arts degree or the Associate of Science degree, but not both.

Posthumous Degrees

Enrolled students whose untimely death prevents degree completion may be awarded a posthumous degree.

Posthumous degrees may be awarded to deceased undergraduate students who have fewer than one semester of classes (12 credit hours) left in their degree plan and meet all college and GPA requirements

Graduation Application

A student who is a candidate for graduation may apply at www.VictoriaCollege.edu/Graduation. Victoria College will award degrees when earned as determined by a curriculum audit against the student's declared major.

Graduates with a Level 1 Certificate or higher are eligible to participate in the graduation ceremony.

Course Substitutions

Course substitutions may be considered for an Associate of Applied Science Degree or for the Certificate for selected Career & Technical Education Programs. Substitutions must be initiated with the appropriate department chair or dean. Career & Technical Education courses may not be substituted for general education courses.

Transfer Courses

If a student successfully completes the core curriculum at a Texas public institution of higher education or receives a bachelor's degree from a regionally accredited college or university, that block of courses may be transferred to Victoria College and may be substituted for the Victoria College Core Curriculum. A student shall receive academic credit for each of the courses transferred and may not be required to take additional courses to complete the Victoria College Core Curriculum. Please visit the Advising & Counseling Services Office for more information.

Associate of Arts Interdisciplinary Studies Degree Associate of Science Interdisciplinary Studies Degree

The Associate of Arts (AA) and Associate of Science (AS) interdisciplinary degrees are designed for transfer as the freshman and sophomore requirements for a Bachelor of Arts (BA) or a Bachelor of Science (BS) degree at most public colleges and universities. Students ensure transferability of their courses by working with their Victoria College advisor as well as by consulting the four-year university where they intend to transfer. Students also guarantee course transferability by meeting with an academic advisor before completing a cumulative total of 30 or more semester credit hours. Although intended for transfer, these multidisciplinary degrees provide valuable marketable skills such as communication, critical thinking, empirical and quantitative skills, personal and social responsibility, and teamwork.

Only courses from the Community College General Academic Course Guide Manual (ACGM) can be used towards the Associate of Arts or Associate of Science degree.

Associate of Arts Interdisciplinary Studies Degree

To earn an Associate of Arts Interdisciplinary Studies degree, students must complete the following requirements:

1. Unconditional admission or the removal of all entrance conditions.
2. Completion of a **minimum of 60 semester credit hours** with at least a 2.0 grade point average. Only Victoria College courses will be used in grade point average calculation.
3. Completion of at least 25 percent of semester credit hours earned through instruction at Victoria College.
4. Meet minimum standards of all areas of the assessment test to satisfy the Texas Success Initiative or meet exemption requirements.
5. Completion of Core Curriculum (42 hours). See page 25.
6. Meet with an academic advisor directly before or directly after completing 30 credit hours.
7. Create a degree plan for academic transfer, in consultation with an academic advisor.
8. Completion of SPCH 1311, 1315, 1318, or 1321
9. Completion of BCIS 1305 or COSC 1301
10. Completion of one literature course (3 hours) **in addition to core requirements.**
Select one course: ENGL 2322, 2323, 2327, 2328
11. Completion of two science courses with at least one course being a lab science course (may be used to satisfy core requirements).

Associate of Arts Interdisciplinary Studies Degree

Freshman Year		
Fall Semester		
ENGL 1301	Composition 1 (Core 010)	3
SPCH (See Core Curriculum* 090)		3
HIST (See Core Curriculum* 060)		3
MATH (See Core Curriculum* 020)		3
EDUC 1300 ¹	Learning Frameworks (Core 090)	3

Spring Semester		
HIST (See Core Curriculum* 060)		3
Creative Arts (See Core Curriculum* 050)		3
Life and Physical Science (See Core Curriculum* 030) – must be a lab science		4
ENGL 1302 or ENGL 2311	Composition II (Core 010)	3
	Technical & Business Writing (Core 010)	
BCIS 1305 or COSC 1301	Business Computer Applications (Core 090)	3
	Introduction to Computing (Core 090)	

Sophomore Year		
Fall Semester		
Life and Physical Science (See Core Curriculum* 030)		3
GOVT 2305	Federal Government (Core 070)	3
Social and Behavioral Science (See Core Curriculum* 080)		3
Language, Philosophy & Culture (See Core Curriculum* 040)		3
Elective*		3

Spring Semester		
Additional Literature Course		3
GOVT 2306	Texas Government (070)	3
Elective*		3
Elective*		3
Elective*		2

*See Core Curriculum – Students should choose the specific course(s) required by the university department (major) to which you are planning to transfer.

*A minimum of 60 credit hours is needed for completion. Please see your advisor to determine if these elective hours are needed.

¹Required for all first-time-in-college students.

Associate of Science Interdisciplinary Studies Degree

To earn an Associate of Science Interdisciplinary Studies degree, students must complete the following requirements:

1. Unconditional admission or the removal of all entrance conditions.
2. Completion of a **minimum of 60 semester credit hours** with at least a 2.0 grade point average. Only Victoria College courses will be used in grade point average calculation.
3. Completion of at least 25 percent of semester credit hours earned through instruction at Victoria College.
4. Meet minimum standards of all areas of the assessment test to satisfy the Texas Success Initiative or meet exemption requirements.
5. Completion of Core Curriculum (42 hours). See page 25.
6. Meeting with an academic advisor directly before or directly after completing 30 credit hours.
7. Creating a degree plan for academic transfer, in consultation with an academic advisor.
8. Completion of SPCH 1311, 1315, 1318, or 1321
9. Completion of BCIS 1305 or COSC 1301
10. Completion of one mathematics course (3-4 hours) **in addition to core requirements**. Select one course: MATH 1314, 1316, 1324, 1325, 1332, 1342, 2312, 2413, 2414, or BUSI 2305.
11. Completion of two lab science courses (may be used to satisfy core requirements).

Associate of Science Interdisciplinary Studies Degree

Freshman Year		
Fall Semester		
ENGL 1301	Composition 1 (Core 010)	3
Life and Physical Science (See Core Curriculum* 030) – must be a lab science)		4
HIST (See Core Curriculum* 060)		3
MATH (See Core Curriculum* 020)		3
EDUC 1300 ¹	Learning Frameworks (Core 090)	3

Spring Semester		
HIST (See Core Curriculum* 060)		3
Creative Arts (See Core Curriculum* 050)		3
ENGL 1302 or ENGL 2311	Composition II (Core 010)	3
Technical & Business Writing (Core 010)		
Life and Physical Science (See Core Curriculum* 030) – must be a lab science		4
Additional Math Course or BUSI 2305 Business Statistics		3

Sophomore Year		
Fall Semester		
SPCH (See Core Curriculum* 090)		3
GOVT 2305	Federal Government (Core 070)	3
Social and Behavioral Science (See Core Curriculum* 080)		3
Elective*		3
Elective*		3

Spring Semester		
Language, Philosophy & Culture (See Core Curriculum* 040)		3
GOVT 2306	Texas Government (070)	3
BCIS 1305 or COSC 1301	Business Computer Applications (Core 090)	3
Introduction to Computing (Core 090)		
Elective*		3
Elective*		1

*See Core Curriculum – Students should choose the specific course(s) required by the university department (major) to which you are planning to transfer.

+A minimum of 60 credit hours are needed for completion. Please see an advisor to determine if these elective hours are needed

¹Required for all first-time-in-college students.

Associate of Applied Science Degree

To earn an associate of applied science degree, students must complete the following requirements:

1. Unconditional admission or the removal of all entrance conditions.
2. Completion of a minimum of 60 semester credit hours with at least a 2.0 grade point average. Only Victoria College courses will be used in grade point average calculation.
3. Completion of all courses in the program of study as outlined in the catalog.
4. Completion of at least 25 percent of major-field courses including the capstone course, if any, earned through instruction at Victoria College. Exceptions for work/life experience may be granted for those seeking degrees in Criminal Justice or Emergency Medical Services provided all other requirements have been satisfied.
5. Meet minimum standards of all areas of the assessment test to satisfy the Texas Success Initiative or meet exemption requirements.

Certificate in a Career & Technical Program

Victoria College grants a certificate in a variety of Career & Technical Education programs. To earn a Certificate of Completion, students must complete the following requirements:

1. Unconditional admission or the removal of all entrance conditions.
2. Completion of the minimum semester credit hours as outlined in the program of study in the catalog with at least a 2.0 grade point average. Only Victoria College courses will be used in the grade point average calculation.
3. Completion of at least 25 percent of major-field courses including the capstone course, if any, earned through instruction at Victoria College.

Certificate in an Allied Health Program

Victoria College grants a certificate in Vocational Nursing (VN). To earn a Certificate of Completion in the VN Program, students must complete the following requirements:

1. Completion of all semester credit hours outlined in the VN Program of Study in the catalog with a grade of C or better in each course.
2. Completion of at least 25 percent of the VN courses including the capstone course earned through instruction at Victoria College.
3. See the Vocational Nursing Program of Study in this catalog for information regarding admission to the program.

Academic Transfer

Liberal arts and sciences courses at VC are designed to transfer to a four-year university and are central to completing an Associate of Arts Interdisciplinary Studies or Associate of Science Interdisciplinary Studies degree. Students who earn a degree in general studies at VC and then transfer will have completed all of the core lower division requirements for any public university in Texas. The following areas of study are popular choices among VC students who plan to transfer to a university:

Art & Design	Government	Pre-Dental/Pre-Medical/
Biology	History	Pre-Pharmacy/Pre-Veterinary
Chemistry	Interdisciplinary Studies	Psychology
Engineering	Mathematics	Sociology
English	Music	Spanish
Geography	Physical Education	Speech
Geology	Physics	

Students should visit with one of VC's academic advisors to create a transfer plan customized to fit the requirements of any university they choose.

Victoria College Developmental Education

Victoria College faculty, staff, and administration are committed to the success of every student enrolled at Victoria College. Most courses at Victoria College require students to demonstrate appropriate reading, writing, and/or mathematics skills prior to enrollment in those courses.

When placement scores indicate that students need additional preparation for college-level courses, students are required to enroll in developmental education courses or appropriate Non-course Competency-Based Options (NCBO) in those areas identified each semester until students are Texas Success Initiative (TSI) complete. Under certain circumstances for students who score close to college-level on the TSI Assessment, co-enrollment in a college-level class may be possible. Students who are not TSI complete must meet with an advisor to register. Co-requisite delivery options are only available in face-to-face settings. Students who are not TSI complete are only allowed to enroll in one corresponding college-level course (the co-requisite course) for each NCBO or remediation until they are TSI complete.

Victoria College provides a developmental education course and/or NCBOs for those students needing additional preparation to transition into college-level English and reading courses. Placement is based on the student's scores in reading and writing on the Texas Success Initiative (TSI) Assessment.

Victoria College provides two math pathways for students, depending on their long-term goals. Students who plan to major in science, math, or business should choose the Algebraic/Calculus pathway. Other students

may opt for the non-Algebraic pathway. In the Algebraic/Calculus pathway, Victoria College provides two levels of non-algebraic pathway and/or NCBOs for those students who need additional preparation for college-level algebraic-intensive math courses. In the non-Algebraic pathway, Victoria College provides a non-algebraic pathway and/or NCBOs for those students who need additional preparation for college-level non-algebraic-intensive math courses. See page 133 for more details about college readiness in math.

A grade of SA, SB, SC, or UF will be assigned in all developmental education courses. These grades are not used for graduation purposes, and the courses do not apply to the number of credits required for a degree or certificate.

Students who are not college-ready in multiple areas will be required to complete EDUC 1300 with a grade of C or better, regardless of the number of credit hours that have been completed. This is in addition to the required developmental education.

Students who are not TSI complete are only allowed to enroll in one corresponding college level course (the co-requisite course) per semester until they are TSI complete.

Please refer to the Required Testing section of this catalog (page 19) for additional information concerning the Texas Success Initiative and college readiness.

The following co-requisite delivery options are available. Students will be co-enrolled in a course 1 and a course 2 and could become TSI complete if they meet the criteria.

COURSE 1	COURSE 2	TSI COMPLETE
INRW 0016 ¹ : Grade S or U	INRW 0301: Grade SC or better	Yes
INRW 0017 ¹ : Grade S or U	Gateway Course ² : Grade C or better	Yes
INRW 0301: Grade SC or better	Gateway Course ² : Grade C or better	Yes
INRW 0301: Grade SC or better	Gateway Course ² : Grade D or below ³	Yes
INRW 0301: Grade UF	Gateway Course ² : Grade C or better	Yes
INRW 0301: Grade UF	Gateway Course ² : Grade D or below ³	No

¹ Satisfactory attendance and participation are required for successful completion of course requirements.

² The following are considered gateway courses ENGL 1301, ENGL 2311, and HUMA 1301.

³ A course grade of "D" in a gateway course may not meet the prerequisite standards for future courses and may not transfer to another institution.

Victoria College Adult Education

Victoria College Adult Education provides noncredit, free, high-quality educational programs that focus on:

- Adult literacy
- High school equivalency preparation
- Workforce training
- English proficiency for speakers of other languages

Registration

Registration and enrollment are provided on a regularly scheduled basis. Instructional periods are approximately four weeks. Applications for enrollment are accepted daily. The enrollment process includes assessment for skill levels and advising to determine services. The enrollment process must be completed with all required paperwork in place before receiving education services.

Note: This program exists to serve undereducated adults. Adults scoring higher than a 12.9 (grade equivalency) on the state-mandated assessment instrument Test of Adult Basic Education (TABE) are not eligible to attend Adult Basic Education classes.

Classes are also periodically offered in nearby counties: Calhoun, DeWitt, Goliad, Gonzales, Jackson, and Lavaca. Individuals seeking information about classes are welcome to stop by the Adult Education Office located in the Continuing Education Center, Suite 107 or call (361) 573-7323.

Adult Basic Education (ABE)

Adult Basic Education offers classes in the core academic subjects such as reading, writing, math, science, and social studies. Curriculum is structured within a real-world context and emphasizes life skills. Students also receive instruction to improve their workplace skills including job attainment, retention, and advancement. Students set their own educational goals and work at their own pace. Basic skills classes may be useful for high school equivalency, college, or employment preparation or for personal or family educational advancement.

Students Accelerating through Integrated Learning (SAIL)

The SAIL Program combines adult basic education with skills training in the following areas: Health Careers, Industrial Trades, and Office Management. Information sessions are held every Wednesday at 9 a.m. and 6 p.m. at the Victoria College Continuing Education Center, Room 207.

English as a Second Language (ESL):

ESL classes are available to individuals with limited English proficiency. An emphasis is placed on reading/writing, speaking/listening, and attaining citizenship. ESL instruction is goal-oriented and self-paced. ESL curriculum is also structured within a real-world context.

Eligibility for ABE and ESL:

Any adult aged 18 or older and 16-17 years old under special provision (call for information) with basic education needs.

Academic Standing

Students at Victoria College are expected to maintain a cumulative grade point average of 2.0 or above. A cumulative grade point average is determined by considering all Victoria College courses a student has taken every semester, except those courses in which grades of Q, W, S, SA, SB, SC, U, or UF were received. Students with a cumulative GPA of 2.0 or above are in **good standing**.

Transfer Students

Students transferring from another college/university to Victoria College will be admitted without regard to probation status from their former college or university.

Academic Warning

Students are placed on **academic warning** when their cumulative GPA drops below 2.0 after being on good standing.

Students on academic warning will be required to enroll in a free 12-week Student Success Course (SDEV 0012) consisting of a weekly class-session:

1. Students who are on academic warning and fail to increase their cumulative GPA to a 2.0 or higher at the end of the semester, but make a semester GPA of a 2.0 or higher will be placed on academic probation and will be permitted to return to Victoria College the following semester.

2. Students who are on academic warning and fail to increase their cumulative and semester GPA to a 2.0 or higher will be placed on academic suspension and will not be permitted to return to Victoria College until one long semester (fall or spring) has elapsed. Once the long semester is complete, the student's academic standing reverts to academic probation and they can enroll in classes.

Academic Probation

Students on academic probation will be required to meet bi-weekly with a success coach.

1. Students who are on academic probation and fail to increase their cumulative GPA to a 2.0 or higher at the end of the semester, but make a semester GPA of 2.0 or higher will continue on academic probation and will be permitted to return to Victoria College the following semester.

2. Students who are on academic probation and fail to increase their cumulative and semester GPA to a 2.0 or higher will be placed on academic suspension and will not be permitted to return to Victoria College until one long semester (fall or spring) has elapsed. Once the long semester is complete, the student's academic standing reverts to academic probation and they can enroll in classes.

Academic Suspension

Students who are on academic warning or academic probation and fail to increase their cumulative and semester GPA to a 2.0 or higher will not be permitted to return to Victoria College until one long semester (fall or spring) has elapsed. Once the long semester is complete, the student's academic standing reverts to academic probation and they can enroll in classes. They must meet with the Dean of Academic Support & Student Success for a personal interview, adhere to the terms of the Agreement of Understanding, and are required to continue meeting bi-weekly with a success coach.

Academic Intervention

Students are placed on academic intervention when their cumulative GPA drops below 2.0 after being on good standing.

Requirements for students on academic intervention:

- Attend six Success Coaching sessions
- Attend The Learning Lab once a week
- Engage with a Learning Assistant for support at least once per week

Students who are on academic intervention and fail to increase their cumulative GPA to a 2.0 or higher at the end of the semester will be placed on academic recovery.

Academic Recovery

Requirements for students on academic recovery:

- Meet with the Dean of Academic Support and Student Success.
- Limit to 1-2 classes
- Attend six Success Coaching sessions
- Engage with a Learning Assistant for support at least once per week
- Attend The Learning Lab once a week
- Meet with assigned Academic Advisor twice within the semester

1. Students who are on academic recovery and fail to increase their cumulative GPA to a 2.0 or higher at the end of the semester, but make a semester GPA of a 2.0 or higher will remain on academic recovery and will be permitted to return to Victoria College the following semester.
2. Students who are on academic recovery and fail to increase their cumulative and semester GPA to a 2.0 or higher will remain on academic recovery and a hold preventing registration will be placed on their account.
 - a. If the student met all the requirements of academic recovery, the student will be permitted to return to Victoria College the following semester and will remain on academic recovery with special requirements.
 - i. Meet with the Dean of Academic Support and Student Success.
 - ii. Limit to 1-2 classes
 - b. If the student did not meet all of the requirements of academic recovery, the student will not be permitted to return to Victoria College until one long semester (fall or spring) has elapsed. Once the long semester is complete, the student will be permitted to return to Victoria College the following semester and will remain on academic recovery.

Grades

Grades

The grades used in Victoria College records and reports are:

A	(90-100, excellent)
B	(80-89, good)
C	(70-79, average)
D	(60-69, poor—lowest passing grade)
F	(59 and below, failure)
FX	(59 and below, failure due to non-attendance)
S	Satisfactory
SA	Satisfactory
SB	Satisfactory
SC	Satisfactory
U	Unsatisfactory
UF	Unsatisfactory
W	Withdrawn (indicates an official withdrawal from a course by a student or administrative action)
I	Incomplete
Q	Insufficient cause drop

The grade of I (incomplete) is given at the instructor's discretion when extenuating circumstances cause a student to be unable to finish the semester (validity of extenuating circumstances is determined by the instructor). The student must make arrangements with the instructor prior to the final exam to award the incomplete. In order to receive an "I" the faculty member and the student must sign an Agreement of Settlement of I Grade form. An incomplete (I) will be changed to a letter grade (A,B,C,D,F,SA,SB,SC,UF) if the student takes the final exam or makes up the work that is prescribed by the instructor. An incomplete not removed within the **date noted on the Incomplete Grade Agreement form will be changed to an F or UF**. Only the instructor of the course may grant an extension of time.

In compliance with SB 412, students needing an incomplete (incomplete-leave of absence) for parenting issues or pregnancy-related problems may receive up to 120 days to complete course work. Students in these situations requesting an incomplete-leave of absence should communicate this need

Students who believe they have not received grades based upon a fair and just evaluation as measured by the standards written on the syllabus given by the instructor at the first or second class meeting must report the matter in writing to the appropriate dean no later than 10 days after the first class day of the next semester. For further information, refer to the *VC Student Handbook*.

Grade Points

A four-point system for expressing in numerical terms the quality of academic scholarship achieved by the student is used in determining eligibility for honors, probation, enforced withdrawal, financial aid, membership in student organizations, etc. The system is as follows:

- Each grade of **A** earns **4 grade points** for each semester hour of the course.
- Each grade of **B** earns **3 grade points** for each semester hour of the course.
- Each grade of **C** earns **2 grade points** for each semester hour of the course.
- Each grade of **D** earns **1 grade point** for each semester hour of the course.
- Each grade of **F** earns **0 grade points** for each semester hour of the course.
- Each grade of **FX** earns **0 grade points** for each semester hour of the course.

Grades of **W, S, SA, SB, SC, U, UF, I, Q** are not awarded grade points and, therefore, these hours are not used in the computation of a grade point average.

Grade Point Average (GPA)

Cumulative Grade Point Average

- Beginning with the Spring 2010 semester, a single cumulative GPA is computed using only credit hours in which a grade of A,B,C,D, F, or FX was earned. **This cumulative GPA is used for determining academic standing and financial aid warning/suspension status.**
- Repeating a Course(s) - In most cases, when a student repeats a course at Victoria College, the highest grade earned for the course will be used in the computation of the cumulative grade point average. **Exceptions: For students applying for admission into the Associate Degree Nursing (ADN) or Physical Therapist Assistant (PTA) programs, the most recent attempt at repeated course work of non-ADN and non-PTA courses will count toward program admission scores.**
- The GPA is calculated by totaling the number of grade points earned and dividing by the number of credits applied toward the GPA. The resulting GPA is truncated following the third decimal (e.g. 1.99672 = 1.996). The college does not round the GPA.

Grade Reports

Electronic grade reports are available in the Pirate Portal > Student Dashboard > View Grades link

Eight and Five Weeks Report

Midterm grades are made available to the student at the end of the first eight weeks for courses lasting 16 weeks for the fall and spring semesters only. Midterm grades for courses lasting fewer than 16 weeks are not posted. GPA calculations, including eight and five-week, are calculated periodically during the semester at the conclusion of certain parts of term.

Semester Report

Final grades are available through the Pirate Portal > Student Dashboard > View Grades link. Students' login and passwords are required to access grades.

Guided Pathways

The Texas Guided Pathways Model is an integrated, institution-wide approach to student success based on intentionally designed and structured educational experiences that guide each student effectively and efficiently from her/his point of entry through attainment of high-quality postsecondary credentials and careers with value in the labor market. Central to the pathways model are clear, educationally coherent program maps that are aligned to what will be expected of students upon program completion in the workforce and in education at the next level in a given field. Students are helped from the start to explore academic and career options, choose a program of study, and develop a plan based on the program maps. These plans simplify student decision-making and enable colleges to provide predictable schedules, frequent feedback, and targeted support as needed to help students stay on track and complete their programs more efficiently. They also facilitate efforts by faculty to ensure that students are building the skills across their programs that they will need to succeed in employment and further education.

In support of the student's successful progression, VC requires that all students meet with an academic advisor upon successful completion of 15, 30, and 45 credit hours before enrolling within their next semester. During these advising sessions, topics such as academic goal setting, course progression and selection, as well as professional and transfer planning will be discussed.

Registration

Advisor-assisted Registration

The College calendar (see pages 12-13) designates the dates for registration at the beginning of each session. The class schedule is posted each semester in the Pirate Portal and at www.VictoriaCollege.edu/ClassSchedule which lists detailed dates and procedures as well as any revisions or adjustments. Students must meet with the correct academic advisor for their career pathway. To determine who the student's academic advisor is visit www.VictoriaCollege.edu/AcademicAdvising. Inquiries about advising should be directed to the Advising & Counseling Services Office at (361) 582-2400.

During the registration process, students will:

1. Develop a schedule and register for classes
2. Pay tuition and fees

Students will not be officially enrolled until all tuition and fees have been paid in full or students have made arrangements with the Payments Office to utilize the installment plan. The Payments Office is located in the Student Services Building and can be contacted at (361) 485-6840.

Online Registration

A student may register using online registration if the following requirements are met:

1. Students are college ready (TSI complete) or students are exempt.
2. There are no holds on record (admissions, library, parking, etc.).
3. If the student is returning to VC, the application process for readmission has been completed
4. If the student is transferring in from another institution, the application process has been completed, including evaluation of transfer classes
5. The student is not on academic suspension.
6. Student does not need to register in a developmental education course.

A username and password can be retrieved through the Pirate Portal once the application process has been completed. For assistance with login and password retrieval, contact the Help Desk at (361) 582-2509. This login information will be used as a security measure each time a transaction takes place and should be known only by the student.

Semesters, Sessions, and Credit

The College operates on the following plan:

- **Fall and spring semesters** of 16 weeks
- **Fast-Track classes** of five-week or eight-week terms throughout the fall and spring semesters
- **Winter Interim session** of 10 days available over a three-week period between the end of the fall semester and the beginning of the spring semester
- **May Interim session** of 10 days available over a three-week period between the end of the spring semester and the beginning of the first summer session
- **Summer session** divided into multiple terms of varying lengths not to exceed 13 weeks. The majority of courses are approximately five weeks to eight weeks.

The unit of credit in college is the semester credit hour, which is the credit earned by passing a lecture course which meets one hour per week for a semester or a lab class which meets three hours per week for a semester. The normal load for a student varies from twelve to eighteen semester credit hours.

In the summer session, a full-time student normally earns twelve semester hours in two terms. The Association of Texas Colleges sets 14 semester hours as the maximum, which may be earned in a summer.

Course Load

Course Load Per Semester/Session

- **Fall and/or spring semesters**
Students may enroll in a maximum of 18 hours. Exceptions for over the 18 hours must be approved by the Director of Advising & Counseling Services.
- **Summer sessions**
Students may enroll in six semester credit hours per five-week summer session. Summer term exceptions (such as 2 three-hour courses in addition to a physical education course) must be approved by the Director of Advising & Counseling Services.
- **Interim Session**
Students may enroll in a maximum of one course. Students may be granted permission to enroll in excess of the allowable number of courses by the Director of Advising & Counseling Services.

Course Definitions

In addition to fall, spring, summer, and fast-track courses, the following are available:

- **Block Scheduling**
The legislation requires a block scheduled program to allow a full-time student to enroll in a defined block of courses, such as a morning, full-day, afternoon, evening, or weekend to provide course scheduling predictability from semester to semester. In addition, the block scheduled program should allow the students to enroll in a block of courses rather than individual courses and for the college to provide the schedule for the next semester in advance. Limited programs are available that follow block schedule program rules.
- **Course Pairing**
An instructional strategy whereby students are enrolled simultaneously in a developmental education course and/or intervention and the entry-level freshman course of the same subject matter within the same semester or for students TSI-deficient in Reading into the appropriate entry-level gateway course, such as history, psychology, sociology, or government. The developmental component provides support that advances students' success in the entry-level freshman course. Enrollment in both the developmental and credit-level course must be maintained for the entire semester. If a drop, whether initiated by the student or not, is processed for either the developmental or credit-level course, students will be dropped from both courses.
- **Non-Course Competency-Based Option and Intervention (also known as NCBO)**
Interventions that use learning approaches designed to address a student's identified weaknesses and effectively and efficiently prepare the student for college-level work. These interventions must be overseen by an instructor of record, must not fit traditional course frameworks, and cannot include advising or learning support activities already connected to a traditional course; interventions may include, but are not limited to, learning assistance, supplemental instruction, or labs.

Credit by Exam

Victoria College recognizes that students, by reasons independent of the college environment, may already have achieved college-level proficiency in credit courses. Therefore, students at Victoria College may receive credit for this achievement (1) through national standardized testing and/or (2) through a local subject area exam. The following examinations comprise the basis of the Victoria College program: College Level Examination Program (CLEP), College Board Advanced Placement (AP) Examinations, Enhanced American College Testing (ACT) Program, College Board (SAT) Program, International Baccalaureate Diploma (IBD) Program, and the Victoria College Departmental Course Examinations.

To have credit by exam posted on their permanent record, students must complete the Petition to Record Credit by Examination available in the Admissions & Records Office or in the Welcome Center.

- Credit earned by examination will be awarded after official enrollment and completion of at least three hours at Victoria College in a credit course.
- Credit will be granted only for courses in which a student has neither a passing nor a failing grade.
- Credit by exam will be accepted as “credit only” (CR) and will not affect a student’s grade point average.
- Credit by exam can be used to meet prerequisites for higher-level courses.
- Credit by exam satisfies degree requirements in the same way as credit earned by passing courses.
- Credit by exam performance standards are set by the department in which the courses are taught and are subject to change at the department’s discretion.

Victoria College Credit By Examination and Minimum Score Requirements

Discipline	VC Credit	Test	Minimum Score
BIOLOGY			
	4 hours-BIOL 1408	AP	3
	8 hours-BIOL 1408	CLEP	50
	4 hours-BIOL 1408	IBD: Standard Level	4
	8 hours-BIOL 1406 & 1407	IBD: Higher Level	6
CHEMISTRY			
	4 hours-CHEM 1406	AP	4
	4 hours-CHEM 1411	AP	5
	4 hours-CHEM 1406	CLEP	50
	4 hours-CHEM 1406	IBD: Standard Level	4
	4 hours-CHEM 1411	IBD: Higher Level	5
	8 hours-CHEM 1411 & 1412	IBD: Higher Level	6
COMPUTER INFORMATION SYSTEMS			
	3 hours-COSC 1301	Departmental Exam	Contact Department
	3 hours-ITSC 1325	A+ Essentials and A+ Practical Application	Reports with passing score
	3 hours-ITSC 1309	Departmental Exam	Contact Department
	3 hours-ITSY 1342	Security+Exam	Contact Department
CRIMINAL JUSTICE			
	3 hours-CJLE 1506	Hold Current State Certification	Contact Department
	3 hours-CJLE 1512	Hold Current State Certification	Contact Department
	3 hours-CJLE 1518	Hold Current State Certification	Contact Department
	3 hours-CJLE 1524	Hold Current State Certification	Contact Department
ECONOMICS			
	3 hours-ECON 2301	IBD: Standard Level	4-7
	3 hours-ECON 2301	IBD: Higher Level	4-7
	3 hours-ECON 2301	CLEP (Principles of Macroeconomics)	50
	3 hours-ECON 2301	AP (Macroeconomics)	3
	3 hours-ECON 2302	CLEP (Principles of Microeconomics)	50
	3 hours-ECON 2302	AP (Microeconomics)	3
ELECTRONICS			
	3 hours-CETT 1302	Departmental Exam	Contact Department
	3 hours-CETT 1329	Departmental Exam	Contact Department

ADMISSIONS & ACADEMIC REGULATIONS

EMERGENCY MEDICAL SERVICE PROFESSIONS

5 hours-EMSP 1501	National Registry EMT Exam	Contact Department
1 hour- EMSP 1160	National Registry EMT Exam	Contact Department
4 hours-EMSP 1438	National Registry AEMT Exam	Contact Department
3 hours-EMSP 1356	National Registry AEMT Exam	Contact Department
3 hours-EMSP 1355	National Registry AEMT Exam	Contact Department
2 hours-EMSP 1261	National Registry AEMT Exam	Contact Department
2 hours-EMSP 2206	National Registry Paramedic Exam	Contact Department
3 hours-EMSP 2330	National Registry Paramedic Exam	Contact Department
3 hours-EMSP 2338	National Registry Paramedic Exam	Contact Department
4 hours-EMSP 2434	National Registry Paramedic Exam	Contact Department
4 hours-EMSP 2444	National Registry Paramedic Exam	Contact Department
3 hours-EMSP 2363	National Registry Paramedic Exam	Contact Department
2 hours-EMSP 2262	National Registry Paramedic Exam	Contact Department

ENGLISH

3 hours-ENGL 1301	IBD: Standard Level	4
3 hours-ENGL 1301	IBD: Higher Level	4
3 hours-ENGL 1301	CLEP (College Composition)	50
3 hours-ENGL 1301	AP (Language & Composition)	3-5
3 hours-ENGL 1302	IBD: Standard Level (Extended Essay=A)	4
3 hours-ENGL 1302	IBD: Higher Level (Extended Essay=A)	4
3 hours-ENGL 1302	AP (Language and Composition)	5
3 hours-ENGL 2322, 2323, 2327, or 2328	AP (Literature and Composition)	5

ENVIRONMENTAL SCIENCE

3 hours-ENVR 1301 or GEOL 1305	AP	3
3 hours-ENVR 1301 or GEOL 1305	IBD: Environmental Systems	3

GEOGRAPHY

3 hours-GEOG 1303	IBD: Standard Level	4-7
3 hours-GEOG 1303	IBD: Higher Level	4-7

GOVERNMENT

3 hours-GOVT 2305	CLEP (American Government)	50
3 hours-GOVT 2305	AP (Comparative Government and Politics)	3

HISTORY (U.S.)

3 hours-HIST 1301	CLEP (History of the United States I)	50
3 hours-HIST 1301 or HIST 1302	AP (United States History)	3
3 hours-HIST 1302	CLEP (History of the United States II)	50

MATHEMATICS

Credit for MATH 0300	ALEKS PPL	14
Credit for MATH 0401	ALEKS PPL	30
Credit for MATH 0303	ALEKS PPL	46
3 hours-MATH 1314	CLEP (College Algebra)	50
3 hours-MATH 1314	IBD: Mathematics & Approches SL	6
3 hours-MATH 1314	IBD: Mathematics & Approches HL	5
3 hours-MATH 1314	IBD: Mathematics: Applications & Interpretations SL	4
3 hours-MATH 1314	IBD: Mathematics: Methods SL	4
3 hours-MATH 1314	IBD: Further Mathematics	4
3 hours-MATH 1314	SAT I (Mathematics)	650
3 hours-MATH 1316	IBD: Mathematics Studies SL	5
3 hours-MATH 1316	IBD: Further Mathematics	5
3 hours-MATH 1342	AP (Statistics)	3
4 hours-MATH 2412	AP (Calculus AB)	3
4 hours-MATH 2412	AP (Calculus BC)(AB subscore)	3
4 hours-MATH 2412	CLEP (Precalculus)	50
7 hours-MATH 1316 & 2412	IBD: Mathematics HL	5
4 hours-MATH 2413	AP (Calculus AB)	4
4-hours-MATH 2413	AP (Calculus BC)	3
4-hours-MATH 2413 & 2414	AP (Calculus BC)	4
4 hours-MATH 2413	CLEP (Calculus)	50

ADMISSIONS & ACADEMIC REGULATIONS

MUSIC

3 hours-MUSI 1306	IBD: Standard Level	4
3 hours-MUSI 1306	IBD: Higher Level	4

PHILOSOPHY

3 hours-PHIL 1301	IBD: Standard Level	4
3 hours-PHIL 1301	IBD: Higher Level	4

PHYSICS

4 hours PHYS 1401	AP (Physics I)	3
4 hours PHYS 1401	IBD: Physics SL	4
4 hours PHYS 1402	AP (Physics I)	3
4 hours PHYS 1402	IBD: Physics HL	4
4 hours PHYS 2425	AP (Physics C - Mechanics)	3
4 hours PHYS 2426	AP (Physics C - Electricity and Magnetism)	3

PROCESS TECHNOLOGY

3 hour – PTAC 1302	Departmental Exam	Contact Department
3 hour – PTAC 1308	Departmental Exam	Contact Department

PSYCHOLOGY

3 hours-PSYC 2301	IBD: Standard Level	4-7
3 hours-PSYC 2301	IBD: Higher Level	4-7
3 hours-PSYC 2301	CLEP (Introductory Psychology)	50
3 hours-PSYC 2301	AP (Psychology)	3

SOCIOLOGY

3 hours-SOCI 1301	CLEP (Introductory Sociology)	50
-------------------	-------------------------------	----

SPANISH

8 hours-SPAN 1411,1412	CLEP (Spanish)	50
11 hours-SPAN 2311	CLEP (Spanish)	60
14 hours-SPAN 2312	CLEP (Spanish)	70

VISUAL ART

3 hours-ARTS 1301	IBD: Standard Level	4
3 hours-ARTS 1301	IBD: Higher Level	4

WELDING

4 hours-WLDG 1421 *	Departmental Exam	Contact Department
3 hours-DFTG 1325 **	Departmental Exam	Contact Department
3 hour – MCHN 1343**	Departmental Exam	Contact Department

*Exam is written and “hands-on” welding skills.

**Exam is written only.

Advanced Placement (AP) exams are offered once each year in May, usually in high schools that offer college-level courses based on AP course descriptions.

Other technical courses may be available for credit by exam. Please contact the appropriate department or program chair for more information.

Locally Articulated Credit

Students who took selected technical courses at certain area high schools will have their credit held in escrow at Victoria College for 24 months after the date of the students' high school graduation. The students will receive their college credit from Victoria College when they complete the following steps:

1. The student must have an 80 (3.0) final average or better in the high school course for which credit is requested.
2. The student must have an official high school transcript forwarded to Victoria College.
3. The student must successfully complete six hours of credit at Victoria College.
4. Upon successful completion of the above requirements, students must fill out a petition for award of locally articulated credit in the Admissions and Records Office in order to have the appropriate courses posted to their academic transcript.

Locally articulated credit added to Victoria College transcripts will be entered as Articulated Credit.

Locally articulated credit will result in credit only. Grade point average will not be affected. For a current list of locally articulated classes, please see the college website.

Classification of Students

Full-time, Half-time, and Part-time Students

Full-time students	Fall and Spring Semesters: Students enrolled for twelve hours or more Summer Sessions: Students enrolled for six hours or more
Half-time students	Fall and Spring Semesters: Students enrolled for six hours Summer Sessions: Students enrolled for three hours
Part-time students	Students enrolled for less than full-time are considered part-time students.
Freshman students	Students who have earned 0 – 29.99 credit hours.
Sophomore students	Students who have earned 30 – 59.99 credit hours.

Auditing a Class

Students who wish to sit in a class without earning credit may do so on a space-available basis under the Audit policy.

Students must

1. Apply for admission
2. Fill out the Authorization for Class Audit Form located in the Admissions and Records Office.
3. Meet all prerequisites for the class.
4. Receive instructor and dean approval to audit the class.
5. Register for the approved audit class through the Registrar on the last day of registration.
6. Pay the audit fee of \$100 per course (in place of tuition) plus all other course fees.

Courses that are audited do not earn credit and may not be changed to a credit course at a later date. No Senior Citizen Discount can be utilized when auditing a course.

Fall 2006 and after Beginning Freshmen (30-Hour Rule)

HB 1172 and SB 1528 of the 79th Texas Legislature amended the Texas Education Code (Sections 54.014 {54.068 renumbered in 2005}) to limit the number of semester credit hours per undergraduate student that institutions may submit for state funding. This ruling applies to students who first enroll in college in the Fall 2006 semester or later. Additional tuition will be charged to students who have attempted 30 or more credit hours beyond their degree's requirement at Texas public colleges or universities. (This does not include credit hours for which the student paid out-of-state tuition, courses designated as developmental education, any hours removed under Academic Fresh Start, or hours accumulated toward a previous baccalaureate degree.) Students who entered higher education for the first time prior to Fall 1999 while classified for tuition purposes as a Texas resident are exempt.

45-Hour Limit

Senate Bill 345 of the 76th Texas Legislature amended the Texas Education Code to limit the number of semester credit hours per undergraduate student that institutions of higher education may submit for state funding. Specifically, higher rates of tuition may be charged to students who exceed the number of hours required for their degree by 45 semester credit hours. This ruling applies to students who first enroll in college in the Fall 1999 semester or later. Credit hours for developmental education and technical courses are not counted in the 45-hour limit.

Legislation Concerning Physical Education Courses

An appropriations rider (Special Provisions Relating Only to State Agencies of Higher Education, Sec. 44, Funding for Physical Education Courses) which became effective in the Fall 1999 semester states that colleges and universities will not receive funds for students who enroll in a physical education course if: 1) it is the only course being taken that semester; 2) the student is non-degree seeking; and 3) the course (same activity) has already been taken. Students falling into this category will be charged additional tuition (approximately \$80.00 per credit hour). If this additional charge is not made at registration, it may be collected during the semester. Failure to pay this charge (if student is notified during the semester rather than at registration) will result in a hold being placed on the student's record. Students can take the same physical education course twice for a maximum of two physical education credits.

Legislation Concerning Courses Attempted More Than Twice

HB 994, passed during the 79th Texas Legislature, allows public junior colleges to charge a student a higher rate of tuition for a course attempted more than twice beginning with Fall 2002 coursework. Public junior colleges do not receive state funds for these types of courses. See the Non-State Funded Course Fee.

Schedule Changes

Students can make schedule changes through their Pirate Portal or with Academic Advisor assistance up to the last day of registration. Once classes have started, schedule changes can only be conducted in the first 2 days of classes, and changes must be completed with Academic Advisor assistance.

Dropping a Course

If a student registers for classes but does not attend or stops attending, regardless if the student has paid or not, the student must officially drop or withdraw. The student must complete the Online Drop Request Form, located in the Pirate Portal, prior to the last drop date. Failure to do so may result in an F on the student's transcript for each incomplete class. If a student drops from a paired co-requisite course, then the student is also dropped from the gateway course he or she is paired with.

Students are encouraged to speak with an academic advisor and a financial aid advisor (if student receives aid) before dropping a class.

Reinstatement Requests

Pre-ORD (Official Reporting Date)

Drop for Nonpayment

Students who fail to pay their fees by the payment deadline will face removal from their registered courses due to nonpayment. During the open registration period, those affected have the opportunity to re-enroll in the original course if space permits or opt for a different course. Once registration closes and classes begin, students dropped for nonpayment can only be reinstated by the Registrar or their Academic Advisor upon immediate payment for classes. Failure to make payment within one day of reinstatement will result in a final drop, and there will be no further reinstatement after this final drop.

Drop for Nonattendance

Instructors must drop a student who has not logged into an online class or physically attended a face-to-face or hybrid class. Students dropped for non-attendance will not be eligible for re-instatement.

Post-ORD (Official Reporting Date)

Drop for Nonpayment

Not eligible for reinstatement.

Drop for Nonattendance

The college reserves the right to drop students from courses due to nonattendance, as requested by the course instructor. If a student is dropped by the instructor, reinstatement is only possible with the instructor's approval. To initiate reinstatement, the student must submit a written request using a form provided by the Registrar or Academic Advisor. The reinstatement request should be submitted no later than the second business day following the withdrawal. Any request submitted after the second business day will not be processed.

Six Drop Rule

Beginning with the 2007-2008 academic year, students enrolling at any college or university for the first time may not drop a total of more than six courses without consequence for other than good cause (as defined below). This total includes any course a student transferring to Victoria College has dropped at another college or university with the exception of private and/or out-of-state colleges/universities. Students transferring to Victoria College from another institution will not be permitted to drop a class for any reason other than good cause until official transcripts from the transferring institution have been received in the Victoria College Admissions & Records Office.

In order to drop a course for good cause, students must provide the appropriate documentation, as described below, to the Advising & Counseling Services Office.

Good cause can include but is not limited to:

1. a severe illness or other debilitating condition that affects the student's ability to satisfactorily complete the course (a doctor's note verifying the condition will be required);
2. responsibility for the care of a sick, injured, or needy person if the provision of that care affects the student's ability to satisfactorily complete the course (a doctor's note verifying the student is the caregiver will be required);
3. the death of a person who is considered to be a member of the student's family or who is otherwise considered to have a sufficiently close relationship to the student (a copy of the death certificate will be required);
4. the active duty service as a member of the Texas National Guard or the armed forces of the United States of either the student or of a person who is considered to be a member of the student's family or who is otherwise considered to have a sufficiently close relationship to the student that the person's active military service is considered to be a showing of good cause (a copy of the military member's orders will be required);
5. the change of a student's work schedule that is beyond the control of the student and that affects the student's ability to satisfactorily complete the course (a letter from the employer verifying the change in work schedule); or
6. A disaster declared by the governor that prevents or limits in-person attendance for a period that significantly affects the student's ability to participate in course work.
7. other good cause as determined by the Executive Vice President-Chief Academic Officer or Vice President of Student Services, or designee.

A qualifying re-enrolled student may drop a seventh course in accordance with law.

FAQs – Six Drop Rule

I dropped a course on the second day of the semester. Will this count against me?	No, as long as you drop a 16-week course before the 12th class day of the semester, the course will not count as one of the six. If the course meets fewer than 16 weeks, the College will determine the deadline based on course length.
I'm taking a science class that has a lab. If I drop the lecture and the lab, will it count as two classes?	No. Lab courses taken concurrently with lecture courses where enrollment in the lab course is required in order to enroll in the lecture course are not considered part of the six course drop limit.
I dropped a course in the summer of 2006. Will that count as one of the six?	No, the six drop limit applies only to students who are taking classes for the first time in the fall of 2007 or later.
I am dropping all of my classes because I am moving. Will they be counted as part of the six course drop limit?	No. Courses dropped in order to withdraw completely from the College are not considered as part of the six course drop limit for the purposes of this policy.
What happens if I drop seven classes?	The college will not allow you to drop seven classes. The grade you have earned in the seventh course will be recorded on your transcript. If you stop attending class, that grade will be an F.
I'm going to a four-year university in the fall. If I return to take classes at Victoria College next summer and decide to drop one of those classes, will the university count the VC class as one of my six?	Yes. A total of six courses can be dropped. The six can come from multiple colleges and universities.
I need to drop a course for good cause but I don't see my good cause reason listed. What do I do?	Make an appointment to talk with either the Executive Vice President-Chief Academic Officer or the Vice President of Student Services or their designee.

FAQs – How do I drop a class?

If you are dropping a class*:
Do one of the following:
1. Schedule an appointment to visit with an academic advisor in the Advising & Counseling Office. Please visit www.VictoriaCollege.edu/AcademicAdvising for steps on scheduling an appointment. Available Monday-Thursday 7:30 a.m.-6 p.m. and Friday 7:30 a.m.-5 p.m. Please visit www.VictoriaCollege.edu for summer hours.
2. Submit an Online Drop Request Form completed within the Pirate Portal. Pirate Portal > Student Dashboard > Drop Classes link
* Beginning with the 2007-2008 academic year, students enrolling in a college or university for the first time may not drop a total of more than six courses for other than good cause.
* Students in selective admission programs must follow drop procedures established by the specific program. Students receiving Financial Aid must contact a Financial Aid Counselor prior to withdrawing from the College.

How do I completely withdraw from the college?

If you are withdrawing from the college*:
Do one of the following:
Schedule an appointment to visit with an academic advisor in the Advising & Counseling Office. Please visit www.VictoriaCollege.edu/AcademicAdvising for steps on scheduling an appointment. Available Monday-Thursday 7:30 a.m.-6 p.m. and Friday 7:30 a.m.-5 p.m. Please visit www.VictoriaCollege.edu for summer hours.
2. Submit an Online Drop Request Form completed within the Pirate Portal. Pirate Portal > Student Dashboard > Drop Classes link
* Students in selective admission programs must follow withdrawal procedures established by the specific program. Students receiving financial aid must contact a Financial Aid Counselor prior to withdrawing from the College.

What is the deadline to withdraw without consequence?

Semester	Term Length	Last day to drop without penalty
Fall	4 weeks	3rd class day of the semester
Spring	4 weeks	3rd class day of the semester
Fall	5 weeks	4th class day of the semester
Spring	5 weeks	4th class day of the semester
Fall	16 weeks	12th class day of the semester
Spring	16 weeks	12th class day of the semester
Fall	14 weeks	10th class day of the semester
Spring	14 weeks	10th class day of the semester
Summer	6 to 10 weeks	College will determine the deadline based on course length
Summer	5 weeks or shorter	College will determine the deadline based on course length
Fast-track	8 weeks	6th class day of the semester

Effects of Course Load Reduction/ Total Withdrawals

- All withdrawals through the Friday of the 10th week of classes during the fall and spring semesters will result in a course grade of W or Q. Unless the course is dropped for good cause, the withdrawal will count toward the six course drop limit and will be noted as Q. Courses dropped for good cause will be noted on the transcript as a W.
- After the 10th week of classes, NO WITHDRAWALS will be permitted.

Students on financial aid should check with the Financial Aid Office prior to dropping a course to determine the effects of the course load reduction on financial aid eligibility. Student receiving Title IV Federal Funds please note the following:

Withdrawing from Classes – Students who withdraw completely from all classes may be responsible for the repayment of some or all of the financial aid they received. Any nonrefundable tuition and fees originally paid for with financial aid may also be owed. Students should consult with a Financial Aid Counselor prior to withdrawing from classes.

Failing all classes – Students who fail all classes OR have a combination of withdrawal(s) and/or failing grades(s) may be responsible for the repayment of some or all of the financial aid they have received.

IMPORTANT: If sufficient financial aid (Pell, SEOG, Direct Loans, TPEG, Scholarships) has been awarded to pay all fees, awards will automatically be used to offset those fees on the date they are due.

NOTE: A Federal Refund Regulation will apply to all students receiving Federal Title IV funding who withdraw from the College before 60% of the period of enrollment has been completed. The law requires that when a student withdraws during a period of enrollment, the amount of financial aid earned up to that point is determined by a specific formula. A student's withdrawal date is the last date of attendance as determined by the instructor roster. Based on the last date of attendance, if the student received less assistance than the amount earned, he or she will receive those additional funds. If the student received more assistance than was earned, the excess funds must be returned.

Distance Education

Distance education course standards, college credit, content, and transferability are the same as traditional courses offered on campus. Students have the same rights, privileges, and responsibilities as on-campus students. Distance education courses are transcribed the same as on-campus courses. The registration process and Texas Success Initiative requirements for distance education courses are the same as for all other Victoria College courses.

COURSES

Online courses (ONL) are courses in which the content is delivered asynchronously, completely over the Internet. Students may need to come on campus several times as determined by the course instructor for specific activities or for testing totaling no more than 15% of the class.

Real-time remote courses (WBX) are courses in which the content is delivered synchronously via Webex at regularly scheduled times. Students can join from any location of their choice as long as they have the technology resources needed. Students may need to come on campus several times as determined by the course instructor for specific activities or for testing totaling no more than 15% of the class.

Hybrid courses (HYB) are courses in which the content is delivered through a combination of online (asynchronously) and on-campus (synchronously) instruction. The online portion is more than 50% but less than 85% of the class.

Alternating courses (ALT) are courses in which the content is delivered synchronously, alternating between face-to-face and Webex at regularly scheduled times. Students may need to come on campus several times as determined by the course instructor for specific activities or for testing.

To take an online, real-time remote, hybrid, or alternating course, students will need access to a computer equipped with a webcam and speakers and with a stable Internet connection. Course may require certain minimum hardware and software configurations on a student's machine. These requirements are the responsibility of the student. Students can use any of the on-campus computers in the open computer labs or the library to complete their coursework; however, these open-access areas are will not accommodate proctored testing.

Interactive Television (ITV) courses are courses in which the content is delivered synchronously via Webex at regularly scheduled times to a remote classroom site. Students and faculty meet in an interactive television classroom and interact with other students and/or faculty at a remote location.

TESTING

Some distance education courses may require one to five proctored (supervised) exams during the semester. Proctored exams may be accomplished in the Testing Center on the main campus, the Gonzales Center, or an approved off-campus testing site at the discretion of the course instructor. Students are responsible for the cost of off-campus or remote proctoring. All final exams must be proctored. Each instructor determines the need for additional proctored exam or exams.

ORIENTATION SESSIONS

The Institutional Effectiveness and Learning Technologies Department holds Canvas Orientation sessions. These sessions do not cover course-specific material, but are designed to explain how to use the technology so that students can spend their time concentrating on the course content. All students are welcome to attend, regardless of the mode of instruction because all courses utilize Canvas in some form. Additionally, some instructors may hold virtual or on-campus orientation sessions specific to their courses.

CANVAS ORIENTATION COURSE

A Canvas Student Orientation Course is located in Canvas on the Help Menu. This course remains available to students during their entire time at Victoria College. The information in this course is updated regularly to reflect Canvas' updates.

Final Exams

1. Semester Final Examinations

Examinations are normally given at the end of each semester/term according to a schedule prepared by the Admissions and Records Office. Classes with a schedule that deviates from the normal semester schedule will be given final exams when those classes end. All final examinations must be proctored, and no student is exempt from taking the final exam. In general, final exams are not given early and must be completed in one attempt but on a case-by-case basis, the division dean may allow exceptions. Proctored examinations, which are not to exceed two and a half hours and must be completed in one attempt. At the discretion of the instructor, the exam will be offered no sooner than the Friday prior to the week of final exams in either an online environment in an approved Testing Center, via remote proctoring, or face-to-face using the same format as traditional class finals. Students should not be required to take exams during times that conflict with the final exam schedule prepared by the Admissions & Records Office.

2. Online Final Examinations

Proctored examinations, which are not to exceed three hours, will be offered during the week of final exams in either an online environment in a Testing Center or face-to-face using the same format as traditional class finals. Students should not be required to take exams during times that conflict with the final exam schedule prepared by the Admissions & Records Office.

3. Winter and May Interim Final Examinations

Proctored final examinations will be offered on the last day of the interim semester in either an online environment in a Testing Center or face-to-face.

4. Condensed Courses Final Examinations

Courses taught in an online environment during the 1st 8-weeks will be given during the last two days of the 8-week session. Face-to-face courses taught during the 1st 8-weeks will schedule exams on the last class meeting of semester.

Courses taught in an online environment during the 2nd 8-weeks will be given during the last two days of the 8-week session. Face-to-face courses taught during the 2nd 8-weeks will schedule exams following the official final exam schedule prepared by the Admissions & Records Office.

5. Postponed Examination

If a student is unable to take an exam as scheduled, the student must petition the instructor in writing prior to the scheduled time of the final in order to reschedule the exam.

Dean's List

Students will be listed on the Dean's List for a given semester if they meet the following criteria: complete at least 12 8 semester hours during that semester (excluding developmental courses), earn a 3.50 or higher semester grade point average on graded courses, and have no grades of U or F for that semester.

Catalog Year Designation for Degree and/or Certificate Requirements

It is the responsibility of the student to know and to satisfy all of the requirements listed under his or her specific catalog if the student intends to graduate from Victoria College. Since requirements and programs are subject to change, students should be aware of current regulations and requirements at all times.

Catalog year designations are made according to the following guidelines:

- **First Time VC Student** – Students entering Victoria College for the first time are assigned to the catalog in effect at the semester and/or session of entry. These students must follow the degree and/or certificate requirements as specified in that catalog, or any subsequent catalog of their choice, as long as the length of time of a student's enrollment does not exceed five years.
- **VC Student whose enrollment exceeds five years** – Students whose enrollment at Victoria College exceeds five years will forfeit the initial catalog designation. These students must then meet the degree and/or certificate requirements specified in a catalog no more than five years old.
- **Student not enrolled for two or more consecutive semesters** – Students who are not enrolled for two or more consecutive regular (fall or spring) semesters must meet the degree and/or certificate requirements of the catalog in effect at the time of reentry, or any catalog thereafter, not to exceed five years.
- **Degrees and certificates will be awarded from only one catalog.**
- **Students who are admitted or readmitted into selective admission programs** – Students who are admitted or readmitted into selective admission programs must meet the curriculum requirements in the current catalog. If curriculum changes have occurred since the student entered the program of study, the student should contact the program director for guidance.

Graduation Participation and Honors

Participation in graduation ceremonies is optional for those candidates who have met the minimum degree or certificate requirements for:

- the Associate of Science
- the Associate of Arts
- the Associate of Applied Science or
- the Certificate

Participation in a graduation ceremony can only occur within the same academic year that the degree or certificate has been awarded.

Candidates eligible for graduation should complete a Graduation Application at www.VictoriaCollege.edu/Graduation. It is preferred that the Graduation Application be completed within the first two weeks of the semester/term in which the candidate plans to graduate. The highest honor (GPA) graduate(s) for an Associate Degree as well as the highest honor (GPA) graduate(s) for a Certificate will be recognized during the commencement ceremony. Graduation with honors is noted on the official student transcript.

Phi Theta Kappa students will have their membership notated on their diploma, transcript, and in the commencement program. Phi Theta Kappa students must maintain a 3.0 cumulative GPA to receive these notations.

Graduating With Honors

To graduate with honors, a candidate must have a 3.5 Victoria College cumulative grade point average, excluding developmental coursework. Candidates will not be considered for honors unless they have been in attendance at Victoria College for a minimum of two semesters and completed a minimum of 24 semester credit hours in residence.

Honor designations are as follows:

3.5 – 3.69	Cum Laude
3.7 – 3.89	Magna Cum Laude
3.9 – 4.0	Summa Cum Laude

Transfer of Credit

It is the responsibility of the student to familiarize himself or herself with the course requirements of the college or university to which he or she plans to transfer and to make certain the choice of courses and the required grades in those courses are satisfied. Please contact Advising & Counseling Services for additional information.

A university is authorized by the Association of Texas Colleges to accept 66 semester hours from a community college. Students with acceptable grades do not experience any difficulty in transferring 66 hours from Victoria College to senior colleges that are members of the Southern Association of Colleges and Schools Commission on Colleges or other regional accrediting associations.

Students planning to transfer to another educational institution are encouraged to work closely with an advisor from both institutions.

For more information regarding credit transfer, contact the Advising & Counseling Services Office at (361) 572-6416.

Transfer Disputes

Transfer disputes may arise when a Texas institution of higher education does not accept lower-division course credit. To qualify as a dispute, the course(s) in question must be offered by the institution denying the credit (receiving institution), or in the case of upper-level institutions, must be published as a lower-division course accepted for fulfilling lower-level requirements. For community colleges, the course(s) must be listed in the Community College General Academic Course Guide Manual and be offered at the receiving institution. Additionally, the sending institution must challenge the receiving institution's denial of credit.

Instructions for Completing the Transfer Dispute Resolution Form, Rules and Regulations of The Texas Higher Education Coordinating Board, Chapter 5, Subchapter S 5.393:

- Public institutions of higher education shall follow the following procedures in the resolution of credit transfer disputes involving lower-division courses:
 - If an institution of higher education does not accept course credit earned by a student at another institution of higher education, the receiving institution shall give written notice to the student and to the sending institution that transfer of the course credit is denied.
 - The two institutions and the student shall attempt to resolve the transfer of the course credit in accordance with THECB rules and/or guidelines.
 - If the transfer dispute is not resolved to the satisfaction of the student or the sending institution within 45 days after the date the student receives written notice of denial, the institution whose credit is denied for transfer shall notify the Commissioner of Higher Education of the denial.
- The Commissioner of Higher Education or the Commissioner's designee shall make the final determination about the dispute concerning the transfer of course credit and give written notice of the determination to the involved student and institutions.
- All public institutions of higher education shall publish the procedures described in subsections (a) and (b) of this section in their undergraduate course catalogs.
- All public institutions of higher education shall furnish data to the Board on transfer disputes as the Board may require in accord with its statutory responsibilities under Section 61.078(e) of the Education Code.
- If a receiving institution has cause to believe that a course being presented by a student for transfer from another school is not of an acceptable level of quality, it should notify the Commissioner of Higher Education. The Commissioner may investigate the course. If its quality is found to be unacceptable, the Board may discontinue funding for the course.

Transfer Credit Policy

Victoria College accepts grades from accredited colleges and universities as posted on the transferring institution's transcripts.

Official transcripts, including military transcripts, and official score reports for standardized exams such as AP, IB, CLEP, etc. must be submitted to the Admissions & Records Office.

Military Physical Education (PE) Credit

Requests for PE credit will be evaluated by the Admissions & Records Office. One PE credit will be granted for every six months of active duty service not to exceed four credits.

International Transcripts

Coursework from institutions outside the U.S. will be considered on a case by case basis, and these students will be required to furnish an evaluation of their courses. See Methods of Admission: Foreign Students on page 18 for a list of approved evaluation agencies.

A course by course evaluation is not required for Texas Success Initiative (TSI) completion.

Experiential Learning

Victoria College does not grant credit for experiential learning.

Transfer of Credits from Another Institution to VC

Initial evaluation of transfer credits is made in the Advising & Counseling Services Office. College courses on transcripts from other colleges and universities with the Texas Higher Education Coordinating Board (THECB or the Board) common number are accepted as comparable courses. Courses without the THECB common number are evaluated by reviewing catalog descriptions and in some cases, course syllabi. It is the students' responsibility to provide the institution with course descriptions and/or syllabi.

- Advisor conducts initial transcript evaluation by determining which courses need evaluation. Student must submit all college transcripts for a comprehensive transfer evaluation to be completed
- Student is informed of which classes need evaluation and which documentation is needed (course description or syllabus).
- Student submits required documentation electronically through the Transfer Student Evaluation Form.

Access for the form at:

VC Website

www.VictoriaCollege.edu > Getting Started tab > Advising & Counseling link > Services expandable list > Transfer Services link > Resources expandable list > Transfer Evaluation Form link

Pirate Portal

Pirate Portal > Resources folder > Advising & Counseling Services link > Transfer Course Evaluation Tool link.

- Dean receives information and determines, in partnership with discipline expert, if course(s) will transfer in.
- Dean makes a decision, and the student is sent an email link to their student email
- Admissions & Records Office receives an email with Dean's decision to be filled in the student's permanent electronic record

Student requesting a transfer evaluation must allow for 2-4 weeks for transfer evaluation process to be completed.

Job Competency Guarantee

If an employer finds an Associate of Applied Science graduate lacking in technical job skills identified as exit competencies for his/her specific degree program, Victoria College will provide up to nine tuition-free credit hours of skill training under the conditions of the policy.

Conditions which apply to the guarantee are as follows:

1. The graduate must have earned the AAS degree beginning May 1993 or thereafter in a technical/vocational program identified in the college catalog.
2. The graduate must have completed the AAS degree at Victoria College (with a majority of Career & Technical Education/Specialty credits being earned at Victoria College) and must have completed the degree within a four-year time span.
3. Graduates must be employed full-time in an area directly related to the area of program concentration as certified by the Executive Vice President-Chief Academic Officer.
4. Employment must commence within three months of graduation.
5. The employer must certify in writing that the employee is lacking entry-level skills identified by Victoria College as the employee's program competencies and must specify the areas of deficiency within 90 days of the graduate's initial employment.
6. The employer, graduate, and assigned representative(s) of the college will develop a written educational plan for retraining.
7. Retraining will be limited to nine credit hours related to the identified skill deficiency and to those classes regularly scheduled during the period covered by the retraining plan.
8. Students must complete retraining within a calendar year from the time that the retraining plan is signed.
9. The student's sole remedy against Victoria College and its employees for skill deficiencies shall be limited to nine credit hours of tuition and selected expense-free education under the conditions described above. Selected expenses are limited to in-county or out-of-county, registration, building use, student service, and laboratory fees. The graduate and/or employer is responsible for the cost of books, insurance, uniforms, and other course-related expenses.

The guarantee does not imply that the graduate will pass any licensing or qualifying examination for a particular career.

General Regulations

Student Conduct

The rules, procedures, rights, responsibilities, and policies set forth in this document are designed to ensure that students have an environment that is conducive to learning and to protect student rights as well as the rights of the College. By this publication of the rules governing student conduct, Victoria College recognizes that students have the right to know the circumstances and manner in which this disciplinary power will be exercised and advises students that disciplinary rules will be enforced.

The Victoria College Discipline System

The Board of Trustees delegates the responsibility for student discipline to the President of the College. The Vice President of Student Services and the Executive Vice President-Chief Academic Officer are the administrators designated by the President of the College to be responsible for the administration of the Student Code of Conduct in their respective areas.

Misconduct

The actions listed and defined below are punishable disciplinary offenses and applicable to situations that occur on College property or at College sponsored activities, or off-campus or at non-College sponsored activities where the commission of acts, which constitute a violation of local, state or federal law, interfere with, are detrimental to, or incompatible with the College's educational mission as set forth in its mission statement, policies and regulations. Students have a responsibility and obligation to be fully acquainted and comply with published rules, regulations, and policies of the College.

Prohibited Acts of Misconduct

1. Academic Misconduct

• Cheating

Cheating includes, but is not limited to, students wrongfully giving, taking, or presenting any information or material not their own with the intent of aiding themselves or others with any academic work or misrepresenting their own or others work product or knowledge.

• Plagiarism

All academic work, written or otherwise, submitted by a student to an instructor or other academic supervisor is expected to be the result of the student's own thought, research, or self-expression. In cases in which students feel uncertain about a question of plagiarism, they are obliged to consult the instructor on the matter prior to submitting any work. When students submit work purported to be their own but which in any way borrows ideas, organization, wording, or anything else from another source without appropriate acknowledgment, they are guilty of plagiarism.

• Failure to Comply with Course/Program Requirements

Students enrolled in courses offered within the College's various areas of study are provided standards of classroom conduct within the course syllabus at the discretion of the course instructor. Additionally, students enrolled in a selective admissions program are provided with a handbook(s) that sets forth rules and regulations that detail a student's responsibilities and conduct within the program. In both cases, the standards of conduct are specifically related to, and intended to ensure compliance with, the academic requirements and goals of the course or program. Students must adhere to these conduct guidelines as well as those outlined in the *VC Student Handbook Code of Conduct*. Students found guilty of violating course or program-specific rules and regulations, as outlined in each program's student handbook, may be subject to academic misconduct sanctions to include possible withdrawal from the program.

2. Actions Against Members of the College Community

• Interference, coercion, disruption, or reckless behavior which impedes, impairs, or disrupts the College mission, processes, or functions or which endangers others or interferes with the rights of others.

• Harassment, including but not limited to, sexual or racial harassment, via any means, including through email. "Harassment" is conduct that creates an intimidating, hostile, or offensive environment that is persistent or extreme and reasonably likely to cause intimidation such that it interferes with or adversely affects the person(s) educational, learning, or work environment.

• Abusive, drunken, violent or excessively disruptive behavior. A student engages in "drunken" behavior when he or she is intoxicated after the consumption of alcoholic beverages to the degree that the student may endanger himself or herself, or another person. "Abusive" behavior is behavior that is aggressive, coercive or controlling, destructive, harassing, intimidating, isolating, and threatening toward another person(s), such that it interferes with or adversely affects the person(s) educational, learning or work environment.

• Lewd, indecent or obscene behavior. "Obscene" behavior is defined by Texas Penal Code §43.21;

• Hazing

To view the Board policies associated with this section, visit <https://pol.tasb.org/Policy/Code/1189?filter=FLBC>

Prohibition of Hazing

Hazing is prohibited at Victoria College, on Victoria College property, or while attending Victoria College-sponsored activities on or off campus. The following information is taken from the Texas Education Code Chapter 37, Subchapter F, Section 51.936 of the Texas Higher Education Code, and Board policy FLBC (LEGAL).

Definition of Hazing

"Hazing" means any intentional, knowing, or reckless act occurring on or off a Victoria College campus by one (1) person alone or acting with others, directed against a student for the purpose of pledging, being initiated into, affiliating with, holding office in, or maintaining membership in an organization if the act:

1. is any type of physical brutality, such as whipping, beating, striking, branding, electronic shocking, placing of a harmful substance on the body, or similar activity;
2. involves sleep deprivation, exposure to the elements, confinement in a small space, calisthenics, or other similar activity that subjects the student to an unreasonable risk of harm or that adversely affects the mental or physical health or safety of the student;
3. involves consumption of a food, liquid, alcoholic beverage, liquor, drug, or other substance, other than as described by number 5 below, that subjects the student to an unreasonable risk of harm or that adversely affects the mental or physical health or safety of the student;
4. is any activity that induces, causes, or requires the student to perform a duty or task that involves a violation of the Texas Penal Code; or
5. involves coercing, as defined by Section 1.07, Texas Penal Code, the student to consume:
 - a. a drug; or
 - b. an alcoholic beverage or liquor in an amount that would lead a reasonable person to believe that the student is intoxicated, as defined by Section 49.01, Texas Penal Code.

Definition of Student

For the purpose of this policy, "student" means any person who:

1. is registered in or in attendance at an educational institution;
2. has been accepted for admission at the educational institution where the hazing incident occurs; or
3. intends to attend an educational institution during any of its regular sessions after a period of scheduled vacation.

Definition of Organization

For the purpose of this policy, "organization" means a fraternity, sorority, association, corporation, order, society, corps, club, or student government, a band or musical group or an academic, athletic, cheerleading, or dance team, including any group or team that participates in National Collegiate Athletic Association (NCAA) or National Junior College Athletic Association (NJCAA) competition, or a service, social, or similar group, whose members are primarily students.

GENERAL REGULATIONS

Personal Hazing Offense

A person commits an offense if the person:

1. engages in hazing;
2. solicits, encourages, directs, aids, or attempts to aid another in engaging in hazing;
3. recklessly permits hazing to occur; or
4. has firsthand knowledge of the planning of a specific hazing incident involving a student at Victoria College, or has firsthand knowledge that a specific hazing incident has occurred, and knowingly fails to report that knowledge in writing to the dean of students or other appropriate Victoria College official.

Organization Hazing Offense

An organization commits an offense if the organization:

1. condones or encourages hazing; or
2. if an officer or any combination of members, pledges, or alumni of the organization commits or assists in the commission of hazing.

Hazing Report

Not later than the 14th day before the first (1st) class day of each fall and spring semester, the Dean of Student of Services Office will distribute to each student enrolled at Victoria College a summary of the hazing provisions and an electronic link to a copy of the report on hazing committed on or off campus by an organization registered with or recognized by Victoria College. The report will include information regarding each disciplinary action taken by Victoria College against an organization for hazing and each conviction of hazing under Section 37.153, Texas Higher Education Code by an organization during the three (3) years preceding the date on which the report is issued or updated, including:

1. the name of the organization disciplined or convicted;
2. the date on which the incident occurred or the citation was issued, if applicable;
3. the date on which Victoria College's investigation into the incident, if any, was initiated;
4. a general description:
 - a. of the incident;
 - b. the violations of Victoria College's Student Code of Conduct or the criminal charges, as applicable;
 - c. the findings of Victoria College or the court; and
 - d. any sanctions imposed by Victoria College, or any fines imposed by the court, on the organization; and
5. the date on which Victoria College's disciplinary process was resolved or on which the conviction became final.

To view Victoria College's most recent hazing report, contact the Vice President of Student Services Office at (361) 582-2516 or visit VictoriaCollege.edu/VicePresidentOfStudentServices.

3. Alcohol, Drugs and Narcotics

- Use, possession or distribution of alcohol or illegal drugs in violation of the College's regulation on drugs and alcohol, or in violation of state or federal law.

- Use, possession, or distribution of non-alcoholic beer or other associated mock-alcohol beverages on campus which disrupts the College mission, processes, or functions.

4. Failure to Comply

- Failure to comply with directions or with College officials acting in the performance of their duties.

5. Financial Responsibility

- Passing a worthless check to the College or to a member of the College community acting in an official capacity. A "worthless check" is a check submitted for the payment of money where there are insufficient funds in or on deposit with the bank or other drawee for the payment in full of the check or order, as well as all other checks or orders outstanding at the time of issuance.

6. Firearms, Weapons and Explosives

- Possessing a firearm, location restricted knife, club, explosives, chemical dispensing device other than a small chemical dispenser sold commercially for personal protection, or other item in violation of Texas Penal Code Chapter 46.

- Violating the Victoria College Institutional Policy on handguns located in the *VC Student Handbook*.

A "firearm" is any device designed, made, or adapted to expel a projectile through a barrel by using the energy generated by an explosion or burning substance, or any device readily convertible to that use. A location-restricted knife is a knife with a blade over five and one half inches. A "club" is an instrument that is specially designed, made, or adapted for the purpose of inflicting serious bodily injury or death by striking a person with the instrument, and includes, but is not limited to, a blackjack, a nightstick, a mace, or a tomahawk.

7. Providing False Information

- Falsifying, altering or forging any official College records or documents, employing official College documents or records for purposes of misrepresentation, or causing any official College documents or records to be falsified by means of any misrepresentation.

8. Student Abuse of the Discipline System

- Knowingly giving false testimony or other evidence at any official hearing of the College or knowingly giving false information to any faculty or staff members acting in the performance of their duties.

- The threat or commission of physical violence against any College employee for the purpose of influencing the employee's official actions.

- Bribing any College employee. "Bribing" or "bribery" is the offering, giving, receiving, or soliciting of something of value for the purpose of influencing the action of a College employee in the discharge of his or her professional duties.

- Violation of conditions imposed in connection with one or more of the sanctions enumerated in the Code of Conduct.

9. Theft, Damage, or Unauthorized Use

- Possessing stolen property.

- Defacing, disfiguring, damaging, or destroying public or private property.

- Stealing any item of tangible or intangible public or private property.

- Lifting, taking, or acquiring, without permission, possession of any academic material (tests, information, research papers, notes, books, periodicals, etc.) from a member of the College community (including the theft of instructors' or other students' books and/or material for resale to the Bookstore).

- Unauthorized access to or misuse of College computers, computing programs or service, and/or failure to comply with Victoria College Computer Use Regulations.

10. Unauthorized Entry or Use

- Unauthorized entry or use of College facilities in violation of College policies or regulations or in violation of local, state, or federal law.

11. Violation of Federal, State, or Local Law

- The threat or commission of physical violence against any person;

- The commission of acts which constitute a violation of local, state, or federal law, which interfere with, are detrimental to, or incompatible with the College's educational mission, as set forth in the mission statement, policies, rules, and regulations.

12. Violation of Published College Policies, Rules, or Regulations

- Acts of misconduct which interfere with, are detrimental to, or incompatible with, the College's educational mission, as set forth in its mission statement, policies, rules, and regulations.

Special Notice Regarding Nonacademic Misconduct and Local, State, and Federal Law Enforcement Authorities

In addition to the acts of misconduct specified herein, the minimum standards of individual conduct required by local, State, and Federal penal statutes are both expected and required of every student attending

GENERAL REGULATIONS

the College. Students may be disciplined by the College for violating any such standards of conduct on the campus or off of the campus in any of the following situations: when the incident occurs in connection with an institution-oriented activity, or when the incident has a substantial connection to the interests of the College in maintaining an orderly educational process, even if the student is or may be penalized by government authorities for the same act. A student who admits to, or is found to have engaged in, conduct prohibited by these standards as determined through the College investigation and appeal process, may be subject to discipline, even if no charges are brought by the government, if the student enters a plea bargain, or if the student is granted deferred adjudication.

Definitions

The following definitions apply to and should be read in conjunction with the Prohibited Acts of Misconduct:

- 1. College Property:** "College Property" refers to the Victoria College campus and all of the physical units of operation and resources owned by Victoria College. As such, Internet access, telephones, and other telecommunication devices owned and managed by Victoria College and used in the commission of an act of misconduct results in the misconduct being defined as having occurred "on College property" regardless of where the offense is committed.
- 2. Members of College Community:** All College students, employees, Trustees, contractors, visitors, and guests are defined as "members of the College Community".
- 3. Possessing, possession, or possess:** A student is in "possession," "possesses," or is found to be "possessing" any item, article, thing, or object prohibited by the prohibited acts of misconduct when the item, article, thing, or object is in the student's vehicle, on his/her person, or in a backpack, briefcase, tote bag, or any other carry-all case, or otherwise under their control. The student need not be the owner of the item, article, thing, or object.

Attendance

In general, attendance is defined as being physically present in a face-to-face class and/or the face-to-face portion of a hybrid class at the time attendance is taken. For online classes, attendance is defined as activity in the class a minimum of one time per week.

Attendance will be taken for every class meeting. The method by which attendance is taken will be determined by the faculty member and clearly outlined in the class syllabus. Attendance records will be submitted electronically to the appropriate Division Dean on the last day of the course.

Regular and prompt class attendance is expected of every student. A student's absence means that the student is not able to participate in the class.

Students who miss class due to participation in authorized College activities will not be penalized if the sponsoring organization provides notification of the absence to the instructor as early as possible in advance of the absence. Nor will dual-credit students be penalized for missing class due to a high school-related activity if they provide notification of the absence to the instructor as early as possible in advance of the absence. The student must contact the instructor prior to the absence to develop a plan for making up any missed work in class on the day(s) of the absence. The student must have ample opportunity to make up the work, as determined by the instructor. The instructor may appropriately respond if the student fails to satisfactorily complete the assignment or examination. In the event of a disagreement over what constitutes "ample opportunity" and a reasonable amount of time, the dean will have final ruling. Students enrolled in selective admissions programs must follow specific program policies.

Instructor-Initiated Withdrawals (Drops)

While it is the final responsibility of the student to drop a class that she/he is no longer attending, instructors may drop students under the following conditions:

Pre-ORD (Official Reporting Date)

Instructors **must** drop a student who has not logged into an online class or physically attended a face-to-face or hybrid class prior to the ORD. Instructors must initiate ORD drops by the published deadlines.

Post-ORD (Official Reporting Date)

An instructor **cannot** drop a student with an average of D/UD or better.

Instructors **may** at their discretion drop a student who is not passing without consultation with the student when absences accrued from the first day of class exceed the equivalent of two weeks of the class meetings. For classes that include a separate laboratory, a student may be dropped when absences exceed two weeks of the laboratory meetings or two weeks of the lecture meetings. For classes that don't meet for the traditional 16-week term, an equivalent number of contact hours will be used (i.e. 6 hours for a traditional 3-hour course). Additional division retention practices may be required.

An instructor **cannot** drop a student after 12 weeks of class instruction has been completed for the traditional 16-week term. For classes that don't meet for the traditional 16-week term, an equivalent number of contact hours will be used (i.e. 36 hours for a traditional 3-hour course).

This practice applies to all modes of instruction. Pursuant to Section 51.9111 of the Texas Education Code, active duty military personnel who provide copies of official orders verifying a call to active-duty are exempt from the above practice. Interested parties should refer to the Student Handbook for additional information.

Under special circumstances, an instructor **may** drop a student sooner than outlined above if the special circumstances are clearly noted in the syllabus or program handbook and have been approved in advance by the appropriate Division Dean. Selective admission programs define their attendance and instructor-initiated withdrawal procedures in their syllabi and program handbooks.

Instructors will initiate withdrawals by completing the electronic drop form and forwarding it to the Advising & Counseling Services Office. The electronic drop form is located in the Pirate Portal > Faculty Homepage > Drop Students. The grade at the time of the drop and the last day of attendance must be included on the electronic drop form.

Instructors will set their own make-up policy as outlined in the course syllabus for work missed due to absence(s).

This practice applies to all modes of instruction. Pursuant to Section 51.9111 of the Texas Education Code, active-duty military personnel who provide copies of official orders verifying a call to active duty are exempt from the above practice. Please see the *Victoria College Student Handbook* for the policy regarding absences for military service. The Executive Vice President-Chief Academic Officer can make exceptions to the above rules.

Family Education Rights and Privacy Act of 1974

Victoria College complies with the Family Education Rights and Privacy Act (FERPA) of 1974, which was designed to protect the privacy of education records, to establish the right of students to inspect and review their education records, and to provide guidelines for the correction of inaccurate or misleading data through informal and formal hearings. Students also have the right to file complaints with the FERPA Office concerning alleged failure by the institution to comply with the Act. For additional information, please contact the Admissions & Records Office. Victoria College considers students to be independent of their parents in regard to their education records. However, information may be disclosed to the parents only by obtaining the student's written consent to do so. FERPA Authorization setup is available through the student's Pirate Portal.

Directory Information

The College will release the following items of directory information (as defined by the Family Education Rights and Privacy Act) without the written consent of the student:

- name
- address
- telephone number
- date of birth
- major
- dates of attendance
- degrees awarded
- honors and awards
- full and part-time status
- enrollment and withdrawal verifications
- student classification
- most recent previous institution attended
- participation in officially recognized activities and sports
- weight and height of members of athletic teams
- student ID number
- student VC email address

The College reserves the right, under the Family Education Rights and Privacy Act, to publish this information and routinely furnishes it to loan agencies, insurance companies, prospective employers, family members, etc. Students are responsible for informing the Admissions & Records Office in writing each semester if the above information is not to be released.

Confidentiality and Access of Student Records

The Admissions & Records Office maintains permanent education records of both credit and noncredit courses. The permanent record for credit courses contains the following: student's name, social security number, address, sex, date of birth, mode of admission, TSI or alternative exam scores, academic work undertaken, grades and grade points and credit hours earned, scholastic standing, and degrees and/or certificates awarded. The permanent record for noncredit courses from 1990-present contains the following: student's name, address, social security number, date of birth, sex, courses taken, satisfactory or unsatisfactory completion, CEU's earned, and contact hours.

Student records are released only for use by faculty and professional staff for authorized college-related purposes. The release of student records (transcripts) for off-campus use occurs only with the student's knowledge and consent, or where required by law. Students may obtain an official or unofficial student copy of the permanent record in the Welcome Center or the Admissions & Records Office only with appropriate ID unless the student properly authorizes a third party.

Transcripts

Official transcript will be issued through the online ordering site or with a written, signed request form submitted in person at the Welcome Center by the student. Transcripts will only be released in person with proper identification. Transcript requests will not be accepted via email, fax, or mail. There will be a \$10 charge for official printed transcripts. Upon graduation, two free transcripts will be provided. The Registrar may deny a student's request for a copy of the permanent record if there is a hold on the record.

Transcripts will not be available for current students during the during the last week of a semester and the following week due to end-of-term processing. Notices about availability dates will be posted on www.VictoriaCollege.edu/TranscriptRequest.

Name, Social Security Number, Contact Information Changes

Name changes and social security number changes can be made at the Welcome Center. Name changes will be made at the end of each semester. Documentation must be submitted with the name change request in order for the change to be made. Contact information may be updated through the Pirate Portal or at the Welcome Center.

Messages and Deliveries to Students

The College does not deliver messages to students unless they involve a family, medical, or personal emergency. In certain situations that necessitate a family member or individual contacting the College to notify of a personal or medical emergency regarding the student, the Advising & Counseling Services Office should be contacted at (361) 582-2400.

Graduation, Employment, and Licensure Exam Pass Rates

Information on Victoria College graduation, employment, and licensure exam pass rates is available in the Office of Institutional Effectiveness and Learning Technologies. at www.VictoriaCollege.edu/IELT, and at <https://apps.highered.texas.gov/resumes/>.

Crime Awareness and Prevention Programs

Students: Victoria College students are informed in detail about campus security policies and procedures during Pirate Orientation. In addition, copies of the Victoria College Campus Crime and Security Statistics brochures are distributed to all students during all registration periods and information can be accessed at www.VictoriaCollege.edu/CampusPoliceSecurity.

Employees: Copies of the Victoria College Campus Crime and Security Statistics brochure are distributed annually to all employees and can also be accessed at www.VictoriaCollege.edu/CampusPoliceSecurity.

Students and Employees: Campus Police personnel will post alert bulletins via the Pirate Portal and email to inform employees and students to watch for and report similar activities if a trend of serious or illegal incidents are recorded. All students and employees are encouraged to become safety conscious and to develop habits that, if employed, will help to safeguard both personal and college property.

Clery Act Report

The Jeanne Clery Act, originally known as the Campus Security Act, requires all colleges and universities throughout the United States to disclose information about crime on and around their respective campuses.

The Department of Police and Campus Safety, in accordance with the requirements of the Clery Act, compiles and publishes the annual security report by October 1 of each year. Statistics for the report are obtained from Victoria College's Police & Campus Safety Department, Victoria Police Department, Hallettsville Police Department, and the Gonzales Police Department.

Victoria College provides Vocational Nursing Training programs in Hallettsville and Gonzales and as such, incidents occurring on those sites must be included in the annual report.

A copy of the report may be obtained in the Police & Campus Safety Office (Academic Building, Room 210) during normal business hours or at www.VictoriaCollege.edu/StudentsRightsToKnow.

Reporting Sexual Assault and Other Sexual Misconduct

Students and employees are encouraged to report instances of sexual assault and sexual misconduct. The anonymous sexual assault and sexual misconduct form is available at <https://bit.ly/3iWLRPZ>.

Please Note: Completing the sexual assault and sexual misconduct anonymous reporting form does not constitute a police report. If you are experiencing an emergency, please call 911 or 9-911 from a campus telephone.

The Title IX Coordinator for Victoria College is Terri Kurtz. She can be reached at (361) 572-6463.

Illegal Drugs or Alcohol

Victoria College specifically prohibits the use, possession, or distribution of illegal drugs and alcohol on college property.

Disciplinary actions are described in the Victoria College Code of Student Conduct in the Student Handbook. VC may prosecute as allowed by state statutes.

Victoria College Police & Campus Safety strictly enforces all laws and College regulations pertaining to illegal drugs and alcohol beverages on campus.

Protections for Pregnant and Parenting Students (SB 412)

In compliance with SB 412, students who miss class for reasons related to pregnancy, childbirth, or resulting medical issues will be allowed

- to make up missed assignments or assessments,
- additional time to complete assignments in the same manner as is allowed for a student with a temporary medical condition, and
- access to materials and recordings or lectures for missed classes.

Students needing an incomplete-leave of absence (I) for parenting issues or pregnancy-related problems may receive up to 120 days to complete course work. Students requesting an incomplete-leave of absence should communicate this need to their instructor(s). An incomplete-leave of absence not completed within the date noted on the agreement form will be changed to an "F" or "UF".

The parenting liaison for Victoria College is Brittani Cervantez, Support Services Coordinator. She may be reached at Brittani.Cervantez@VictoriaCollege.edu or (361) 582-2452.

Tuition and Fees

Tuition and Fees

Residents of Texas

SEMESTER HOUR	TUITION	OUT-OF-COUNTY FEE	GENERAL FEE	TECHNOLOGY FEE	IN-COUNTY TOTAL	OUT-OF-COUNTY TOTAL
1	60	61	41	23	124	185
2	120	122	82	46	248	370
3	180	183	123	69	372	555
4	140	244	164	92	496	740
5	300	305	205	115	620	925
6	360	366	246	138	744	1,110
7	420	427	287	161	868	1,295
8	480	488	328	184	992	1,480
9	540	549	369	207	1,116	1,665
10	600	610	410	230	1,240	1,850
11	660	671	451	253	1,364	2,035
12	720	732	492	276	1,488	2,220
13	780	793	533	299	1,612	2,405
14	840	854	574	322	1,736	2,590
15	900	915	615	345	1,860	2,775
16	960	976	656	368	1,984	2,960
17	1,020	1,037	697	391	2,108	3,145
18	1,080	1,098	738	414	2,232	3,330
19	1,140	1,159	779	437	2,356	3,515
20	1,200	1,220	820	460	2,480	3,700
21	1,260	1,281	861	483	2,604	3,885

**ALL TUITION AND FEE RATES ARE SUBJECT TO CHANGE WITHOUT NOTICE.
ALL TUITION AND FEES MUST BE PAID BEFORE ATTENDING CLASS.**

Note: Certain programs may be subject to an additional per credit hour differential tuition. See page 52 for program-specific additional differential tuition rates.

Tuition and fees can be paid using the payment plan. There is a \$20 nonrefundable service fee to use the payment plan. Under this option, one-half of the tuition and fees must be paid at the time of registration with the balance due in one or two payments, depending on the semester. During certain early VIP registrations, the College will offer a payment plan that requires one-fourth down and three installment payments. The payment plan may be initiated online through the Pirate Portal or in person at the Payments Office located in the Student Services Building.

Courses taken for the third time or more will be subject to an additional fee of \$80 per credit hour. See page 53 for a listing of course fees. See page 57 for information regarding State of Texas tuition and fee exemptions.

Tuition and Fees

Nonresidents of Texas, Out-of-Country/Foreign

SEMESTER HOUR	TUITION*	GENERAL FEE	TECHNOLOGY FEE	TOTAL
1	200	41	23	264
2	316	82	46	444
3	474	123	69	666
4	632	164	92	888
5	790	205	115	1,110
6	948	246	138	1,332
7	1,106	287	161	1,554
8	1,264	328	184	1,776
9	1,422	369	207	1,998
10	1,580	410	230	2,220
11	1,738	451	253	2,442
12	1,896	492	276	2,664
13	2,054	533	299	2,886
14	2,212	574	322	3,108
15	2,370	615	345	3,330
16	2,528	656	368	3,552
17	2,686	697	391	3,774
18	2,844	738	414	3,996
19	3,002	779	437	4,218
20	3,160	820	460	4,440
21	3,318	861	483	4,662

*State law requires a minimum tuition charge of \$200.

Note: Certain programs may be subject to an additional per credit hour differential tuition. See page 52 for program-specific additional differential tuition rates.

Courses taken for the third time or more will be subject to an additional fee of \$80 per credit hour. See page 53 for a listing of course fees. See page 57 for information regarding State of Texas tuition and fee exemptions.

Tuition Fees

In-State Tuition Per Credit Hour	60.00
*Out-of-State Tuition Per Credit Hour.....	158.00
Differential Tuition by Program Per Credit Hour	
Electronics & Instrumentation	40.00
Emergency Medical Services	105.00
Nursing-Associate Degree	105.00
Nursing-Vocational	105.00
Physical Therapist Assistant	105.00
Process Technology	40.00
Respiratory Care.....	105.00
Welding.....	40.00

*State law requires a minimum charge of \$200.

High School Dual Enrollment Tuition & Fees (Per Credit Hour)

In-County	78.00
Approximate Allocation:	
Tuition	40.00
General Fee.....	24.00
Technology Fee	14.00
Out-of-County	121.00
Approximate Allocation:	
Tuition	40.00
Out-of-County Fee.....	43.00
General Fee.....	24.00
Technology Fee	14.00
Out-of-State/Foreign	137.00
Approximate Allocation:	
Tuition	56.00
Out-of-County Fee.....	43.00
General Fee.....	24.00
Technology Fee	14.00

Additional Fees

Out-of-County Fee Per Credit Hour	61.00
General Fee Per Credit Hour	41.00
Technology Fee Per Credit Hour.....	23.00
*Installation Service Charge.....	20.00
*Installation Late Fee.....	25.00
*Returned Check Fee	25.00
**Liability Insurance (per course) PTHA 1266, RNSG 1260, RNSG 1261, RNSG 2362, RSPT 1360, RSPT 2360, VNSG 1260	20.00
EMS programs.....	20.00
Liability Insurance (per course) MDCA 1091, NURA 1060, NURA 1013, PHRA 1001, PLAB 1023, VTHT 1008	20.00
Transcript Fee	10.00
American Heart Association (AHA) certification cards (per course) EMSP 1355, EMSP 2330, EMSP 2444.....	15.00

*Nonrefundable fees

**Students who enter any Allied Health Program in the fall, spring, or summer will pay a pro-rated fee.

Testing Fees

*Departmental Credit by Exam	40.00
*Testing Fees	
CLEP	95.00
Certificate Assessment Test.....	15.00
GED Test	145.00
ATI TEAS	75.00
Texas Success Initiative Assessment 2.0 (TSIA2)	12.00
EMSP 1438 and 1501 Standardized Computer Testing	30.00
EMSP 2243 Standardized Computer Testing	120.00
Correspondence Course Proctoring.....	25.00 fee for an exam up to 2 hours
Nursing-Associate Degree (Generic Student Curriculum) RNSG 1523, 2504, 2514, 2535 TEAS.....	316.25
Nursing-Associate Degree (Transition Program) RNSG 1327, 2514, 2535 TEAS	363.00
Nursing-Associate Degree (Generic Student Curriculum) RNSG 1523, 2504, 2514, 2535 NurseThink.....	66.25
Nursing-Associate Degree (Transition Program) RNSG 1327, 2514, 2535 NurseThink	44.17
Nursing-Associate Degree (Generic Student Curriculum) RNSG 1523, 2504, 2514, 2535 ExamSoft	45.74
Nursing-Associate Degree (Transition Program) RNSG 1327, 2514, 2535 ExamSoft	30.49
Nursing-Vocational VNSG 1260, 2260, 2461 Standardized Tests	363.00
Nursing-Vocational VNSG 1329, 1423, 1432 Nurse Think.....	31.67
Nursing-Vocational VNSG 1329, 1423, 1432 ExamSoft	29.77
Respiratory Care RSPT 2231 Standardized Computer Test.....	125.00
Respiratory Care RSPT 2361 NRP	45.00

*Nonrefundable fees

Course Fees

E-Book Course Fee

VC has an institutional digital course materials program in which selected courses are designated “e-book courses” by the faculty. For each designated e-book course, the college charges a mandatory course fee. All students who enroll in a course that requires a college e-book will be charged a course fee which will appear in their overall tuition and fees. Students enrolled in designated e-book courses may access required course materials within the college's online Learning Management System (i.e., Canvas). See course syllabus for details including opt-out information.

Courses with additional fees:

ARTS 2346	102.00
BIOL 0010	90.00
EMSP 1160 Web-based Clinical Documentation Fee	52.50
EMSP 1261, 2262, & 2363 Web-based Clinical Documentation Fee	84.00
ESLR 0016.....	90.00
ESLW 0016	90.00
INRW 0016	90.00
INRW 0017	90.00
ITCC 1344, 2320	24.00
ITSW 1307.....	24.00
MATH 0003, 0014, 0024, 0032, 0042	90.00
Nonstate Funded Course Fee per semester credit hour.....	80.00
Physical Education	
Archery (per course).....	36.00
Bowling (per course).....	36.00
Tennis (per course).....	12.00
Golf (per course).....	60.00
Swim Conditioning (per course).....	36.00
PTHA 1305 APTA Professional Association Fees.....	45.00
PTHA 1266	52.00

Laboratory Fees

ACCT (all courses)	24.00
ACNT 1303, 1311.....	24.00
BCIS 1305	24.00
BIOL (all courses except 1322, 2289, 2306, 2389).....	24.00
BMGT 1307, 2303.....	12.00
CHEM (all courses except 2323, 2325)	24.00
COSC 1301, 1436, 1437	24.00
COSC 1315	12.00
ELEC (CETT/EECT per course).....	30.00
EMSP 1355, 1356, 1438, 1501, 2330, 2434	24.00
EMSP 2243, 2444	150.00
ENTC 1301	24.00
GEOL 1401, 1402, 1403, 1404	24.00
INTC (all courses except 2680)	30.00
ITSE (all courses)	24.00
ITCC (all courses).....	24.00
ITNW (all courses)	24.00
ITSC (all courses)	24.00
ITSY (all courses)	24.00
MUAP (two Semester Hour Credit).....	200.00
MUSI 1116, 1117, 2116, 2117	8.00
MUSI 1181, 1182, 1183, 1192, 2181, 2182	24.00
PHYS (all courses except 1315)	24.00
PTAC 1302, 1354	18.00
PTAC 1410, 1432, 2314, 2420, 2438, 2446	30.00
PTHA 1305, 1413, 1431, 2201, 2409, 2435, 2531	24.00
RNSG 1219, 1260, 1261, 2361, 2362, 2363.....	48.00
RSPT 1240, 1410, 1411, 2135, 2139, 2147, 2310, 1137, 2231, 2414, 2258, 2453, 2325.....	55.00
VNSG 1423, 2331	48.00
WLDG (all courses except DFTG 1325, MCHN 1343)	48.00

Residency Definitions for Tuition & Fees Purposes

A Texas resident is defined as a US citizen (or dependent of a U.S. citizen for the current and preceding year) who has resided continuously in Texas for at least 12 months immediately preceding registration.

A. A **county resident** is a resident of the state of Texas who:

(1) has resided continuously in Victoria County for a period of at least six months immediately preceding registration and who was not claimed as a dependent for federal income tax purposes by the individual's parent or guardian for the current tax year or for the preceding year in which the individual registers. A residence change from Victoria County to outside of the county during the first 12 class days of the fall or spring semester (first four class days of the summer sessions) will result in the student being charged the additional out-of-county tuition fees.

OR

(2) is a dependent of a Texas resident (claimed as a dependent for federal income tax purposes by the individual's parent or guardian at the time of registration and for the preceding tax year) whose parent or guardian has resided continuously in Victoria County for a period of at least six months immediately preceding registration.

B. An **out-of-county resident** is a resident of the state of Texas who:

(1) has not resided continuously in Victoria County for a period of at least six months immediately preceding registration and is independent for income tax purposes for the current year and preceding tax year;

OR

(2) is a dependent of a Texas resident (claimed as a dependent for federal income tax purposes by the individual's parent or guardian at the time of registration and for the preceding tax year) whose parent or guardian has not resided continuously in Victoria County for a period of at least six months immediately preceding registration.

C. A **resident alien** is a student living in the United States under a visa permitting permanent residence and has the same privilege of qualifying for Texas resident status for tuition purposes as do United States citizens. Under this status, the Resident Alien card or appropriate documentation indicating that the student has filed an I-485 form with the Immigration and Naturalization Service must be submitted before the student may register. Students who fail to present the Resident Alien card or appropriate documentation during the registration process will be required to pay nonresident tuition. Resident aliens wishing to be classified as Texas residents must also verify that they have resided in the state at least 12 months prior to registration.

D. A **nonresident** is someone who does not live in Texas but is a citizen of the United States who:

(1) has not resided continuously in the state of Texas for a period of at least 12 months immediately preceding registration and is independent for income tax purposes for the current year and preceding tax year;

OR

(2) is a dependent (claimed as a dependent for federal income tax purposes by the individual's parent or guardian at the time of registration and for the preceding tax year) whose parent or guardian has not resided continuously in the state of Texas for a period of at least 12 months immediately preceding registration.

The Board of Trustees of Victoria College authorizes the waiver of the difference in the rate of tuition for the out-of-county or nonresident and in-county student or his/her dependent(s), who owns property purchased by or before time of enrollment which is subject to ad valorem taxation by the Victoria County Junior College District. The individual, or his/her dependents, applying for such waiver shall verify property ownership by presentation of an ad valorem tax statement or receipt, issued by the tax office of the district; or by presentation of a deed, property closing statement, or other appropriate evidence of ownership of property which is subject to ad valorem taxation by the district. This must be done prior to registration.

E. An **alien or foreign student** is defined as a student who is a citizen of any country other than the United States of America.

Residency Verification Requirements

New students, as well as returning students who were not enrolled the previous semester, are required to submit proof of their Texas residence and Victoria County residence (when applicable). For information regarding the appropriate documentation for verifying residency, contact the Welcome Center.

Verifications should be submitted when application is submitted or during registration. Failure to provide residence verification or failure to pay the additional fees owed will result in denial of future registrations as well as a hold being placed on the student record.

Students planning to apply for a partial tuition refund by providing residence documentation that will result in a residence status change must do so before the official reporting date (as set by the Coordinating Board of Texas) for the current semester. Such refunds will be made for the current semester only and not for prior semesters attended.

Official reporting dates are as follows:

- Fall and spring semesters: 12th class day
- Summer sessions: fourth class day
- Classes of varying lengths: pro-rated accordingly (See page 39 for more details)

If an error is detected in residency determination—either by administrative staff or by erroneous information on the residence portion of the application—additional tuition may be charged during the semester. Failure to pay the additional charges will result in a hold being placed on the student record.

Tuition Rebate

The following Tuition Rebate policy has been set by the Texas Higher Education Coordinating Board.

Sec. 54.0065. TUITION REBATE FOR CERTAIN UNDERGRADUATES.

- (a) A qualified student is eligible for a rebate of a portion of the undergraduate tuition the student has paid if the student:
- (1) is awarded a baccalaureate degree from a general academic teaching institution; and
 - (2) has attempted no more than three hours in excess of the minimum number of semester credit hours required to complete the degree, including transfer credits and course credit earned exclusively by examination.
- (b) The amount of tuition to be rebated to a student under this section is \$1,000, unless the total amount of undergraduate tuition paid by the student to the institution of higher education awarding the degree was less than \$1,000, in which event the amount of tuition to be rebated is an amount equal to the amount of undergraduate tuition paid by the student to the institution. However, a student who paid the institution awarding the degree an amount of undergraduate tuition less than \$1,000 may qualify for an increase in the amount of the rebate, not to exceed a total rebate of \$1,000, for any amount of undergraduate tuition the student paid to other institutions of higher education by providing the institution with proof of the total amount of that tuition paid to other institutions of higher education.
- (c) A student who has transferred from another institution of higher education shall provide the institution awarding the degree an official transcript from each institution attended by the student in order that the total number of hours attempted by the student can be verified.
- (d) To qualify for a rebate under this section, the student must have been a resident of this state and entitled to pay tuition at the rate provided by this chapter for a resident student at all times while pursuing the degree.
- (e) All institutions of higher education shall notify each first-time freshman student of the tuition rebate program.
- (f) The institution awarding the degree shall pay the rebate under this section from local funds.
- (g) If a student entitled to a rebate under this section has an outstanding student loan, including an emergency loan, owed or guaranteed by this state, including the Texas Guaranteed Student Loan Corporation, the institution shall apply the amount of the rebate to the student's loan. If a student has more than one outstanding loan, the institution shall apply the amount of the rebate to the loans as directed by the student or, if the student fails to provide timely instructions on the application of the amount, the institution shall apply the amount of the rebate to the loans according to priorities established by the Coordinating Board. If the amount of the rebate exceeds the amount of the loan indebtedness, the institution shall pay the student the excess amount.
- (h) The Legislature shall account in the General Appropriations Act for the rebates authorized by this section in a way that provides a corresponding increase in the general revenue funds appropriated to the institution. It is the intent of the Legislature that rebates authorized by this section shall be financed by savings to the state resulting from reductions in the number of courses taken by undergraduate students.
- (i) The Coordinating Board, in consultation with the institutions of higher education, shall adopt rules for the administration of this section.

Refund Policy

The 74th Legislature assigned the Coordinating Board the duty of establishing a uniform refund policy for public community and technical colleges in Texas. The following is the refund policy adopted by the Coordinating Board in January 1996.

I. REGULAR SEMESTER LENGTH COURSES

In order for a student withdrawing from regular semester length courses to be entitled to a refund, the student must officially withdraw from Victoria College by submitting the withdrawal request through the drop classes link in the Pirate Portal or by sending an email to Admissions@VictoriaCollege.edu. Students who drop a course(s) or totally withdraw from Victoria College will have their tuition and mandatory fees refunded according to the following schedule:

Total Withdrawals and Course Load Reductions for Fall and Spring Semesters

*Prior to the first class day 100%
 During the first 15 class days..... 70%
 During the 16th through 20th class days .. 25%
 After the 20th class dayNone

Total Withdrawals and Course Load Reductions for Summer Sessions

*Prior to the first class day 100%
 During the first five class days 70%
 During the sixth and seventh class days... 25%
 After seventh class day.....None

NOTE: State law requires Victoria College to apply refunds for tuition and fees paid by a sponsor, donor, or scholarship to the source rather than directly to the student who has withdrawn if the funds were made available through the institution.

NOTE: Not all fees are refundable.

All withdrawals or course load reductions must be processed through the proper office to be official. All refunds will be processed within three to four weeks after the last day to receive a refund for the semester. Any student who early registers and later withdraws will not receive a refund until refunds for the semester for which he/she registered are processed.

Direct deposit refunds are made to students who have designated a checking or savings account through their student portal. If no direct deposit profile has been established, a check is mailed to the student's mailing address of record on file with the registrar.

II. Non-Semester-Length and Flex Entry Courses

The student must officially withdraw from Victoria College by contacting the department with which he/she registered to be entitled to a refund.

Total Withdrawals for flex entry and non-semester-length courses

*Prior to the first class day 100%
 After classes begin, see table on the next page.

*Class days refer to the number of calendar days the institution normally meets for classes, not the days a particular course meets.

Total Withdrawal Refund Table (Non-semester-length)

Length of Class in Weeks	Last Day for 70% Refund	Last Day for 25% Refund
2 or less	2	n/a
3	3	4
4	4	5
5	5	6
6	5	7
7	7	9
8	8	10
9	9	11
10	9	12
11	10	14
12	12	15
13	13	16
14	13	17
15	14	19
16 or longer	15	20

Refunds for Noncredit Courses

Students will receive a 100% refund if a withdrawal request is received before the class begins, or if the class is cancelled by the College. No refund is issued after the class begins. Law Enforcement Academy students will receive an 80 percent refund if the withdrawal is completed during the first five calendar days following the first class meeting.

Federal Financial Aid Return of Title IV Funds Policy

The term "Title IV Funds" refers to the Federal Financial Aid Programs authorized under the Higher Education Act of 1965 and includes the following: Federal Family Education Loan Program, Federal Direct Loans, Federal Perkins Loans, Federal PLUS Loans, Federal Pell Grants, and Federal SEOG.

A federal refund policy will apply to all enrolled students receiving Federal Title IV funding and withdrawing from the College before 60 percent of the period of enrollment has been completed. Students earn their Title IV federal financial aid by attending class in person or participating in online classes. The law requires that when a student withdraws during a period of enrollment, the amount of financial aid that the student has earned up to that point is determined by a specific formula. A student's withdrawal date is the student's last date of attendance and for online classes, the last date of documented participation. Participation in an online class must be more than signing on. It can be assignment completions, group discussions, or discussions with the instructor. Based on the last date of attendance as determined by the instructor roster or by some type of participation in the class as noted by the instructor – if the student received less assistance than the amount that the student earned, the student will be able to receive those additional funds.

This is called a post-withdrawal disbursement. If the student received more assistance than the student earned, the excess funds must be returned. The amount of assistance that a student has earned is determined on a pro-rata basis. For example, if the student completed 30 percent of the payment period of enrollment – as determined by either attending class or participating in some manner that the instructor is able to document – the student earns 30 percent of the assistance the student was originally scheduled to receive. Once the student has completed 60 percent of the period of enrollment, the student earns all of the student's assistance. If a student received excess funds that must be returned, the College must return a portion of the excess equal to the lesser of the student's institutional charges multiplied by the unearned percentage of funds, or the entire amount of the excess funds.

If a student is eligible for any post-withdrawal disbursement, this will be made from available grant funds before available loan funds. Any amounts that have not been disbursed will be used in the Return to Title IV Calculation as the Amount that Could Have Been Disbursed.

Direct deposit refunds are made to students who have designated a checking or savings account through their student portal. If no direct deposit profile has been established, a check is mailed to the student's mailing address of record on file with the registrar.

Withdrawal Information: Please see information on withdrawal procedures and dropping classes, and their requirements. Students are subject to a limit for withdrawals and must contact the Advising & Counseling Services Office for procedures for and consequences of withdrawing from all classes. From a financial aid standpoint, students cannot earn all of their financial aid unless they attend and participate in class for at least 60 percent of the term. This calculation counts all calendar days, including the first and last day of each term, weekends and holidays. Breaks of one week or more are not included in the calculation. Students must stay in school through the 60 percent mark to avoid possible repayment of unearned financial aid.

Module Classes: Module classes are defined as any class that does not span the entire length of the term. These classes may also be referred to as "part of term," "fast track," or "short term" classes.

Federal regulation: *Any student who is enrolled in at least one class that is less than the length of the term is classified for that term as a "module student." This means that even if the student enrolls in and passes a module class or classes, then drops or stops attending remaining full-term classes, he/she may be subject to a Title IV Return calculation (a charge to the student's account for return of unearned tuition) if the total number of days attended in the term is less than 60 percent.*

Victoria College uses the Return to Title IV Calculation Freeze Date (RCFD). The use of an RCFD determines the number of days the student was scheduled to attend by using a fixed point in the payment period or period of enrollment. The Return to Title IV Calculation Freeze Date (RCFD) coincides with the institutions Pell recalculation date (PRD).

The portion of financial aid grants and loans funded, excluding Federal Work-Study, which must be returned to financial aid programs, will be based on the following components:

TUITION & FEES

Date of withdrawal as determined by the College based on the following:	<ul style="list-style-type: none"> The date the student last attended class as reported by the instructor. For online classes, the last date of documentable participation. This must be more than signing into the class. Submitting assignments, group discussions, and discussions with instructor may count as attendance. If the instructor has no documented attendance records, it will be determined the student never attended and will not have earned ANY Title IV funds.
Percentage of the enrollment period earned:	<ul style="list-style-type: none"> Divide the number of days attended by the number of days in the term (including weekends and holidays). If last date of attendance occurs after the 60 percent date, the student has earned all of the financial aid received and no refund will be required.
Subtract the percentage earned from 100 percent to determine the percentage unearned:	<ul style="list-style-type: none"> Multiply the total federal aid received by the calculated percentage unearned. This reflects the total amount of unearned federal aid.
Calculation of Institutional Return:	<ul style="list-style-type: none"> Multiply the percent unearned by the institutional costs to determine the unearned institutional return. Requires student repayment to Victoria College
Calculation of Student Return:	<ul style="list-style-type: none"> Subtract institutional return from the total amount of unearned federal aid. Requires student repayment to Department of Education or Lender.

Financial Aid implications:

Example of a student in module classes:

- Student enrolls in two module classes, both spanning the first five weeks of the term, and one full-term class.
 CLASS A
 3 credits MODULE Final grade: B
 CLASS B
 3 credits MODULE Final grade: A
 CLASS C
 4 credits FULL TERM
 Withdrew on the 33rd day of the term
- Student is paid financial aid based on attendance for the full term.
- Student finishes the module classes, but drops the full-term class the same day the module classes ended.
- Term length is 77 days x 60% = 47 days
- Module classes were 33 days in length ($33/77 = 42.9\%$)
- Earned tuition is 42.9%, unearned is 57.1%
- Student is subject to a TIV Return calculation because he or she earned less than 60% of his/her tuition.
- Satisfactory Academic Progress (SAP) status – will be reviewed at end of term, regardless of repayment of Title IV funds

Unearned Title IV funds are returned to Title IV programs based on a federally mandated formula. Under this formula, **institutions** are obligated to return unearned funds collected for institutional charges to the US Department of Education and/or the student loan lender. Students are obligated to return unearned funds beyond the institutional charges to the Department of Education.

When **institutions** have to return unearned Title IV funds from institutional charges, the money is returned to programs in the following order: Unsubsidized Stafford Loan, Subsidized Stafford Loan, PLUS Loans, Pell Grant, Academic Competitiveness Grant, and FSEOG. These unearned Title IV funds are posted to the student's Victoria College account and must be repaid.

When a **student** has to return unearned Title IV funds that he/she received beyond the institutional charges, the money is returned to programs in the following order: Unsubsidized Stafford Loan, Subsidized Stafford Loan, PLUS Loans, Pell Grant (50%), and FSEOG (50%). Note that student's responsibility for repayment of unearned Title IV **grant** money is reduced by half.

If a student owes unearned Title IV funds from a **federal loan**, the money is repaid to the lender in accordance with the terms and conditions of the promissory note.

The College is required to notify the student within 45 days of determining the student's withdrawal of any **student** portion of unearned Title IV funds from a **federal grant**. The student is allowed 45 days to repay the amount to Victoria College, which will forward the funds to the Department of Education. After that time, payment arrangements must be made with the US Department of Education or eligibility for federal financial aid at any higher education institution will be denied. The student also needs to repay to the **institution** the money that Victoria College is required to return to the Department of Education for the unearned institutional charges.

The institutional charges (tuition and fees) incurred by the student are considered to be paid by Title IV funds for the purpose of the formula, even if the institutional charges were directly paid by a source other than Title IV funds.

Students can repay the student portion of federal loans under the terms and conditions of the promissory note for the loan. However, the unearned portion of the loans that Victoria College must return is posted as a charge to the student account and must be repaid.

State of Texas Tuition Exemption/Waiver Program

Certain tuition exemption/waiver programs are available for reduced tuition and/or fees. For more information about the specific requirements to qualify for a program, review the list at the Texas Higher Education Coordinating Board website at www.CollegeForAllTexans.com or contact the Admissions & Records Office located in the Student Services Building. There are time limits for qualifying for certain exemptions or waivers. Texas Education Code 54.2001 requires that a student receiving a state exemption or waiver must meet the institution's minimum grade point average requirement for making Satisfactory Academic Progress (SAP) in accordance with the institution's eligibility for receiving financial aid. For Victoria College, that requirement is a cumulative Grade Point Average (GPA) of 2.0 or higher. Students with a cumulative GPA less than 2.0 and students who have exceeded maximum hours will not be eligible for a state exemption or waiver. Appeals may be made to the Satisfactory Academic Progress Appeals Committee.

(This page left blank intentionally)

Financial Aid

Financial Aid

The purpose of the Victoria College Financial Aid Office is to assist students in obtaining the financial aid necessary to attend college. Assistance is available in the form of grants, loans, student employment, and scholarships. All students who feel that they need financial assistance are strongly encouraged to visit the Financial Aid Office to learn about the various sources of funds and to determine their eligibility.

Students who wish to apply for any type of financial aid (except merit-based scholarships and non Work-Study student assistant positions) must:

1. be enrolled in classes that pertain toward their degree plan each semester.
2. complete and submit a Free Application for Federal Student Aid (FAFSA). The FAFSA application is available through the FAFSA web site located at <https://studentaid.gov/h/apply-for-aid/afsa>. After submission of the FAFSA to the Federal Processor, students will subsequently receive a FAFSA Submission Summary (FSS).

In order to complete their financial aid file, students must:

1. submit a copy of their high school transcript showing graduation date or submit verification of a GED to the Admissions & Records Office.
2. complete admissions application and be an admitted student to Victoria College.
3. submit ALL official transcripts from each college attended if they are transfer students.

Some student files are selected for verification. Students may be required to provide an IRS tax transcript, verification worksheets, or other miscellaneous forms as identified on the Financial Aid Requirements link in the Pirate Portal.

Federal Ability-to-Benefit Law

High School Graduates or GED Certificates

All students who apply for financial aid must submit a copy of their completed high school transcript or their GED certificate to the Admissions & Records Office. Placement tests will no longer be allowed in lieu of high school diploma or GED.

A student who enrolls for summer sessions and whose high school has not yet had the opportunity to issue transcripts will be allowed to temporarily substitute a letter from the high school registrar which states that the student has completed all requirements for graduation, including passing all sections of the high school exit test. This letter must be submitted in a sealed envelope and must include the following:

- Student's Social Security number
- Confirmation that the student has successfully completed all requirements for graduation, date of graduation, and type of program
- Date issued
- Original signature of the school official

Students who enroll using this type of verification must follow up and furnish the Admissions & Records Office with an official copy of their transcript. These regulations were developed to ensure compliance with federal law. Students who have not met these requirements will NOT be awarded Title IV federal financial aid. No exceptions will be made to this policy.

The Director of Financial Aid, under the direction of the Vice President of Student Services, administers the financial aid program. Financial Aid staff members are available to answer questions and to provide assistance with completing applications. Additional information may be obtained by visiting the Financial Aid Office or by calling or writing:

Office of Financial Aid
Victoria College
2200 E. Red River Street | Victoria, TX 77901
(361) 572-6415
www.VictoriaCollege.edu/FinancialAid

Leading The Way

Victoria College Foundation Board of Directors

Mike RivetPresident
Vee StraussVice President
Bill Gibbens Secretary
Gary Worsham..... Treasurer

Ben Galvan Past President
Luis A. Guerra..... Trustee Representative
Dr. Josie Rivera..... Trustee Representative
John Zacek..... Trustee Representative

Bruce Bauknight, M.D..... Member
Brian Billingsley Member
Bill Blackwell..... Member
Charla Borchers Leon..... Member
Brian Ferguson Member
Penni Gietz Member
Judge Beatriz Q. Gonzalez..... Member
Steve Hipes Member
Dr. Michael Hummel Member
Kathy Hunt..... Member
Clay Kolle..... Member
Jackie Mikesh Member
David Murphy..... Member
Kyle Noack..... Member
LuAnn O'Connor..... Member
Darrell Rangnow Member
Peter Paul Rojas, M.D..... Member
Robert Royer Member
Jake Srp Member
Blaine Warzecha..... Member

Amy Mundy.....Executive Director

Victoria College

Dr. Jennifer KentPresident

Scholarships

A wide variety of scholarships are available at Victoria College (VC). Scholarships include those awarded and administered by the Victoria College Foundation (VCF) as well as those awarded by community and civic organizations. In addition, Victoria College awards Institutional Scholarships for various programs of study and academic merit. The criteria for receiving a scholarship varies according to standards set by donors. Scholarships may be awarded based on GPA, financial need, or a combination of other criteria.

The Victoria College Foundation administers over 100 scholarships for students attending Victoria College. Students must apply and receive acceptance to VC prior to completing the VCF scholarship application. Once students have received acceptance to VC, they will have access to the VCF scholarship application in the Pirate Portal > Student Dashboard > Apply for VC Foundation Scholarships link. Change in GPA, major, Satisfactory Academic Progress (SAP), or other factors may affect the status of scholarship awards.

Additional scholarships are available for Dual Credit, Workforce & Continuing Education, Allied Health Continuing Education as well as Gonzales Center students. Scholarships are also available for other College initiatives.

Victoria College also advertises outside scholarships awarded by various community and civic organizations. These scholarships may require additional paperwork to be completed by the student and are submitted directly to the donor.

The following endowment and scholarship funds are administered by the Victoria College Foundation. Please contact the Victoria College Foundation for complete information.

Endowed Scholarships

Endowment listing as of April 25, 2024

Adam Sclafani Military Veteran Endowed Scholarship
 Alma Griner Endowed Scholarship
 Alvin & Annie Charbula Family Endowment
 Anne Elkowitz Levin Endowed Scholarship
 Aron & Willie Lee Kolle Endowed Scholarship
 Betsy Wright Endowment
 Bill & Nancy Blackwell Family Endowed Scholarship
 Billy Ruddock Endowed Scholarship
 Bob & Mary Ann Brezina/VISD Golf Tournament Endowed Scholarship
 Bruce & Vicki Bauknight Health Career Endowed Scholarship
 C. L. Thomas, Inc. Endowed Scholarship
 Carol Cannon & Darrell Rangnow Engineering Academy Endowment
 Chad A. Slavik Memorial Endowed Scholarship
 Charles & Mary M. Geryk Endowed Scholarship
 Charles D. & Patricia A. Spurlin Endowed Scholarship
 Daughters of the American Colonists - Daniel Braman Chapter
 Endowed Scholarship
 David B. Lack Endowed Scholarship
 Del Papa Distributing Endowed Scholarship
 Diana Giese Rhodes Endowed Scholarship
 Dick Koop Endowed Scholarship
 Dorothy T. Arnold Endowed Scholarship
 Dr. Bud & Kathryn Lee Endowed Scholarship
 Dr. Dale Pigott Memorial Endowed Scholarship
 Dr. Gyda Hallum Endowed Scholarship
 Dr. Marvin H. & Nadine Cheshire Endowed Scholarship
 Dr. Michael & Cora Jo Hummel Endowed Scholarship
 Dr. Roland E. Bing, Jr. Endowed Scholarship
 Drs. George & Ruth Constant Endowed Scholarship
 Edmund & Albina Skloss Endowed Scholarship
 Edwin W. & Diana M. Dentler Endowed Scholarship
 Eleanor Anderson Family Endowed Scholarship
 Elizabeth Killebrew Memorial Endowed Scholarship

Elton E. Calhoun, Jr. Memorial Endowment
 Esther, Glen & David Sunderman Endowed Scholarship
 Ethel Lee Tracy Endowed Scholarship
 Ethel Thurmond Art Endowed Scholarship
 Eunice M. Willis Memorial Endowed Scholarship
 Frank & Alma Lee Marshall Memorial Endowed Scholarship
 George & Ruth Bagnall Endowed Scholarship
 Gladys Bhatia - Excellence in Nursing Endowed Scholarship
 Grizzle Communications Endowed Scholarship
 H-E-B Endowed Scholarship
 Hallie & Beatrice Chinn Endowed Scholarship
 Harry C. & Frankie B. Smith LVN Endowed Scholarship
 Honoring Katie B. Nelson, LVN
 ICT Endowed Scholarship
 Jack R. Morrison, Jr. Endowment
 Jack R. Morrison, Sr. Endowed Scholarship
 Jacques D. Robinson Memorial Endowed Scholarship
 Jake A. Nelson, Jr. Endowed Scholarship
 Jim Lehrer Endowment, Honoring Charles Spurlin
 Jimmy & Michelle Goodson Endowed Scholarship
 John & Helen Newton Memorial Endowed Scholarship
 John W. Stormont Lectures - Texas Coastal Bend Endowment
 Josephine & Thomas Charbula Endowed Scholarship
 Judge Clarence Stevenson Memorial Endowment
 K. R. & Laura Miller Endowed Scholarship
 Kathryn O'Connor Endowment
 Kaye Krebs Memorial Endowed Scholarship
 Kiwanis Club of Suburban Victoria Endowed Scholarship
 Kucera Family Endowed Scholarship
 LeAnn Wendel Memorial Endowed Scholarship
 Lela Welder Cliburn Endowed Scholarship
 Leo & Virginia Welder Endowed Scholarship
 Leonard & Penni Gietz Music Endowed Scholarship
 Linda Dunn Medical Laboratory Technology Endowed Scholarship
 Lota M. Gibson Endowed Scholarship
 Louis & Evelyn Tittizer Endowed Scholarship
 Louise Hume Endowed Scholarship
 Lucille Marie Smith Endowment
 Lucy E. & Richard Crow Endowed Scholarship
 MBA Harold Cade Endowed Scholarship
 M. G. & Lillie A. Johnson Foundation Endowed Scholarship
 Madeline Fleming O'Connor Endowed Scholarship
 Margaret & David Sunderman Endowed Scholarship
 Maria Luisa Correa & Susie Hooks Vandervoort Endowed Scholarship
 Marie Tomforde Endowed Scholarship
 Marsha Shanklin Foundation Endowed Scholarship
 Marty Stockbauer Endowed Scholarship
 Marvin & Faye Brunner Endowed Scholarship
 Honoring Nurse Lori Ann Brunner
 Michael Scott Joy Memorial Endowed Scholarship
 Miguel & Emilia Rojas Endowed Scholarship
 Milton S. & Elizabeth A. Greeson Endowed Scholarship
 Morris & Camille Roberts Endowed Scholarship
 Munson Smith Endowed Scholarship
 Pilot Club of Victoria, Barbara M. Hanna Endowed Scholarship
 Prosperity Bank Endowed Scholarship
 RMA Architects & Interior Designers Endowed Scholarship
 Raymond Dickson Foundation Endowed Scholarship
 Regional Cattlemen's Heritage Society Endowment
 Regional Steel Endowed Scholarship
 Reuben & Connie Murray Endowed Scholarship
 Robert J. Hewitt, Sr. Endowed Scholarship
 Ronald B. Walker Endowed Scholarship
 Soroptimist Club International Endowed Scholarship
 South Texas Foundation for Excellence in Nursing Endowed Scholarship

Susan Windwehen Memorial Endowed Scholarship
 T. Michael O'Connor Endowment
 The Frank Pickens Club Sports Endowed Scholarship
 The Herbst Endowed Scholarship
 The Trull Foundation Endowed Scholarship
 The Victoria Area Nurses Endowed Scholarship
 Tim & Cherie Von Dohlen Endowed Scholarship for Disadvantaged Youth
 Victoria Area Restaurant Group Endowed Scholarship
 VC ADN SNA Endowed Scholarship
 Victoria College Endowed Scholarship
 Victoria College Foundation Endowed Scholarship
 Victoria College Transfer Student Endowed Scholarship
 Victoria Downtown Rotary Club
 Victoria Eye Center Endowed Scholarship
 Victoria Sembradores Educational Foundation Endowed Scholarship
 Victoria/Invista 50th Anniversary Community Appreciation
 Endowed Scholarship
 Victoria-Goliad-Jackson Counties Medical Alliance Endowed Scholarship
 Virginia C. Daniel Nursing Endowed Scholarship
 Vocational Nursing 50th Anniversary Celebration Endowed Scholarship
 in memory of Dr. J. D. Moore and Dr. John W. Stormont
 W. Henry Crain Endowed Scholarship
 Warren Young Memorial Endowed Scholarship
 Wells Fargo Bank Texas, N.A. Endowed Scholarship
 William L. & Anna Crawford Endowed Scholarship
 William Taylor & Mabel Markham Tipton Endowed Scholarship
 Winston L. & Nixie Zirjacks Endowed Scholarship
 Wood Family Endowed Scholarship
 Works of Mercy Endowed Scholarship
 Zac & Evelyn Lentz Endowed Scholarship

Scholarships

Scholarship listing as of April 25, 2024

Allied Health Continuing Education Scholarship
 Bettie Clarke Janda Memorial Scholarship
 Bj Peterson Distinguished ADN Graduate Award
 Chick-Fil-A Servant Leadership Scholarship Honoring Keith Morgan
 Daniel Blue House Welding Scholarship
 Darrell & Carol Rangnow Scholarship
 Debbie Parks Memorial Scholarship
 DeTar Hospital Volunteers Scholarship
 Donna G. Kiening Scholarship
 Donna Sue Machicek Clemmons Scholarship
 Empty Bowls Visual Arts Scholarship
 Gonzales Center Scholarship
 Karl E. "Ollie" Olson Scholarship
 Lewis Allen Scholarship
 Louis W. Chenault, Sr. Scholarship for Nursing
 Marthiljohni Memorial Scholarship
 Stanzel Family Foundation Scholarship
 Thomas A. & Grace E. Innes Scholarship
 TLC Staffing ADN Nursing Scholarship
 Ty Young Memorial Scholarship
 VASA POD Scholarship
 Victoria Civilian Fire Academy Alumni Association Scholarship
 Victoria College Faculty Memorial Scholarship
 Victoria College Police Academy Scholarship
 Victoria Fine Arts Association Scholarship
 Victoria Lions Club Scholarship
 What's Your Story Scholarship
 Workforce & Continuing Education Scholarship

Institutional Scholarship

Victoria College Music Scholarship

Valedictorian

A tuition scholarship is awarded to the highest-ranking graduate of each accredited high school in Texas. Exemption is valid for tuition during both semesters of the freshman year immediately following the student's high school graduation. Fees are not covered and funds may not be used to pay tuition for continuing education classes. The student should send the letter of certification from his/her high school indicating he/she is the highest ranking high school graduate for that high school to the registrar of the college he/she attends.

College for All Texans

Please refer to www.CollegeForAllTexans.com, Apply for Colleges and Financial Aid > Types of Financial Aid for a complete listing of financial aid offered through the state of Texas.

Grants

Victoria College participates in several need-based grant programs, which provide funds that do not have to be repaid. Students who wish to apply for any grant must submit a FAFSA. Proceeds from grants are intended to provide assistance with tuition, fees, books, and living expenses.

Federal Pell Grants

The Federal Pell Grant program is regulated by the federal government and is an important source of financial assistance for eligible students. It is recommended that students applying for a Federal Pell Grant be enrolled for six or more hours. However, a Federal Pell Grant may be available to students who enroll for less than half-time (please contact the Financial Aid Office for additional information concerning less-than-half-time Federal Pell Grants). The amount of the Federal Pell Grant award will vary with the number of semester hours carried and the financial need demonstrated by the student. Students who have demonstrated eligibility and have completed the review process with the Financial Aid Office may use Federal Pell Grant funds at registration. Any additional amount due to the student will be paid later in the semester. **If students are enrolled in courses that do not count toward their degree/certificate, those hours cannot be included in determining their enrollment status. Duration of Pell eligibility is reduced to the equivalent of 12 full-time semesters.**

Books and Supplies for Title IV (Pell Grant, SEOG, Direct Loans) Recipients

Students may charge at the Victoria College Bookstore for books and supplies once they have registered and the Pell Grant funds are authorized to the student account. The student's tuition and fees will be deducted from the authorized aid and the remaining balance will be available to charge against. There are cut-off dates for charging. Please contact the Bookstore for specific schedules. The Bookstore is located in the Library Building, and can be reached at (361) 572-6430. Any unused funds will be refunded to the student approximately 14 days after the term Official Reporting Date (ORD). Authorized Pell funds for bookstore charges for 2nd 8-week fast track courses will be available before classes begin, and the first two days thereafter. Remaining funds will be disbursed to students that same week.

Retaking Coursework

New federal regulations limit students' eligibility for federal aid with regards to repeated courses. Students may not receive federal aid (Pell Grant and Stafford Loans) for courses that were previously taken and passed beyond the first retake. Note: Repeat courses still count toward students' attempted hours for financial aid purposes.

For example, suppose a student takes a course and receives a grade of D. This student needs a C in this course to count for the requirements of the degree. The student takes the course again, receives aid, and earns another D. The student needs to retake the course again, but is no longer eligible for federal aid for that class. Additionally, the student cannot use that course toward enrollment for financial aid purposes. If the student is taking 12 credits, the repeated 3 credit course is no longer eligible. The student's actual enrollment for financial aid purposes must be listed as 9 credits.

Recalculating Pell Grant for changes to Student's Cost, Student Aid Index (SAI), or Enrollment Status.

Victoria College allows for recalculations of a student's Pell Grant after the initial calculation or disbursement, to account for changes to the student's costs, EFC, or enrollment status.

Change in the SAI

If the student's SAI changes due to corrections, updating, or an adjustment, and the SAI change would change the amount of the Pell award, the Financial Aid Office must recalculate the Pell award for the entire award year. If, as a result of the recalculation, the student has received more than his or her award amount, then the student has received an overpayment. In some cases, the Financial Aid Office may be able to adjust an award by reducing or canceling later payments to the student in the same award year.

Change in enrollment status between terms

In a term program that uses credit hours, the Financial Aid Office must calculate a student's payment for each term based on the enrollment status for that term. If a student attended full-time for the first term and then enrolled half-time in the second term, half-time enrollment status must be used to calculate the student's payment for the second term.

Student does not begin attendance in all classes within a term

If the student does not begin attendance in all of his or her classes, resulting in a change in the student's enrollment status, the Financial Aid Office will recalculate the student's award based on the lower enrollment status. A student is considered to have begun attendance in all of his or her classes if the student attends at least one day of class for each course in which that student's enrollment status was determined for Federal Pell Grant eligibility. A student is considered not to have begun attendance in any class in which the school is unable to document that attendance.

Change in enrollment status within a term

It is Victoria College policy to recalculate Pell awards only for enrollment changes that occur up to the Official Reporting Date (ORD) of a term.

The Financial Aid Office will use the student's effective enrollment status on the date of the initial calculation, and there will be no recalculations of the student's Pell Grant for the term due to a subsequent change in enrollment status, assuming the student began attendance in each class. If the student's payment for the term is being disbursed in a subsequent payment period, the Financial Aid Office will pay the student only for the coursework completed in the term. In the case of programs offered with compressed coursework or modules within the terms, Victoria College will not allow any subsequent adjustments to enrollment status once the ORD calculation has been determined.

For example, suppose a student was determined to be registered in 9 credit hours at ORD, and the Pell calculation was performed for three-quarter status. The student then registers during a subsequent registration period for another 3 credit hours. The student is still considered to have a three-quarter time enrollment status and is not eligible for any additional Pell for this term.

Federal Supplemental Educational Opportunity Grant (SEOG)

Federal SEOG is a federally funded program that provides additional grant funding for students receiving Federal Pell Grants. Students who have completed the application for financial aid by the priority deadlines will be given first consideration for these funds. After this deadline, funds will be awarded on a first-come, first-served basis until all monies are exhausted.

Texas Public Education Grant (TPEG)

The TPEG Grant is funded by Victoria College from tuition set aside. Awards are made to students who have completed their application for financial aid by the priority deadline. Funds will be awarded on a first-come, first-served basis until all monies are exhausted. Funds are awarded using a need-based formula of Federal Pell Grant applicants. Certain Continuing Education courses may also qualify for the TPEG award. Please contact the Financial Aid Office for more information.

Toward Excellence, Access & Success Grant (TEXAS Grant)

Beginning with the 2014-2015 year, institutions may not make initial year Texas Grant awards. Institutions may request renewal year Texas Grant funds for eligible students who received an initial year award prior to Fall

2014 either through Victoria College or another public institution. The Texas Higher Education Coordinating Board funds the TEXAS Grant. This grant is aimed at assisting students who have graduated from a Texas high school and completed the recommended high school program or the distinguished achievement program. Eligible students must have financial need and be enrolled either full-time or three-quarter time at an eligible institution within 16 months of high school graduation to receive this grant. Contact the Financial Aid Office for additional eligibility requirements.

Texas Educational Opportunity Grant (TEOG) (formerly known as TEXAS Grant II)

The Texas Higher Education Coordinating Board funds the Texas Educational Opportunity Grant. This grant is aimed at assisting students who have a high school diploma or GED. Eligible students must have financial need and be enrolled at least half-time at an eligible institution within the student's first 30 credit hours to receive this grant. Contact the Financial Aid Office for additional eligibility requirements. For a complete list of exemptions and grants, go to www.CollegeForAllTexans.com, Apply for Colleges and Financial Aid > Students > Financial Aid > Types of Financial Aid.

Loans

Federal Student Loan Programs

Victoria College participates in the William D. Ford Federal Direct Loan Program (DL). The program provides low-interest loans to eligible students enrolled at least half-time in an institution of higher education. Repayment may be deferred until a student ceases to be enrolled at least half-time in an institution of higher education.

All students who wish to apply for DL must meet the following requirements:

1. Students must be currently enrolled for at least 6 credit hours.
2. Students must declare a major with the Registrar's Office.
3. Students must be enrolled in courses that count toward their degree plan or certificate program.
4. Courses that do not count toward the degree plan or certificate program cannot be included in the enrollment status of students for the purpose of determining whether students are full-time or part-time. Repeat courses that are not part of the student's enrollment status (refer to Repeat coursework under Federal Pell Grant section) cannot be included for the purpose of determining whether students are full-time or part-time.
5. Students must meet the requirements of the Satisfactory Academic Progress (SAP) requirements to be eligible to receive any type of financial aid (loans, grants, work-study, etc.).
6. All students obtaining a Direct Loan from Victoria College for the first time will be required to complete entrance counseling on studentaid.gov.
7. Students must complete a loan request form each academic year and a separate summer loan request if needing loans for the summer. Forms can be found at www.VictoriaCollege.edu/FinancialAidForms.
8. Students must complete an MPN with the Department of Education at studentaid.gov. MPNs are good for 10 years.
9. Students must accept loans through the Pirate Portal > Financial Aid Dashboard > Award Offer..

Students' loan eligibility amount will be calculated based on financial need, the number of semester credit hours the student is enrolled in and eligible for (see Repeat Coursework section) each semester (as of the 12th class day during the fall and spring semesters and the fourth class day during summer semesters); the amount of other financial aid (grants, scholarships, work-study, WIA benefits, tuition waivers, etc.) the student may receive; and grade level.

Loan funds are available to cover initial payment of tuition/fees and purchase of books. The first disbursement of loan checks is mailed approximately 30-35 days after the first day of class during the fall and spring semesters and approximately 17-20 days after the first class day during the summer semesters (first-time borrowers must wait 30 days before loans can be disbursed, due to federal regulations.) The student's correct mailing address must be on file in the Admissions & Records Office. Loans will be disbursed in the form of a check or direct deposit to the student's bank account. The student is responsible for setting up direct deposit. It is not College policy to allow students to pick up their checks. Loans are disbursed in two equal payments in accordance with federal regulations. For loans covering one semester, the second disbursement cannot be made until at least 50 percent of the student's enrollment has elapsed.

If anything about the student's financial circumstances change (including the receipt of additional financial aid funds, such as scholarships, grants, work-study, WIA benefits, tuition waivers, etc.) the amount of his/her loan eligibility may change.

Loan recipients must complete Loan Exit Counseling before transferring to another college or university, graduating from Victoria College, dropping below half-time status, or withdrawing. Loan Exit Counseling is available at studentaid.gov.

PROVISIONS AFFECTING DIRECT LOANS ONLY:

- Interest subsidies during the six month grace period are eliminated for new Stafford Loans made on or after July 1, 2012. The repayment period still begins six months after the student is no longer enrolled at least half-time, but interest accrued during those six months will be payable by the student rather than subsidized by the federal government.
- The interest rates for Direct Loans can be found at this website: <https://studentaid.gov/>.
- First-time borrowers on or after July 1, 2013 have a limit on the maximum time period that they can receive Direct Subsidized Loans. This time limit does not apply to Direct Unsubsidized Loans or Direct PLUS Loans. A student may not receive Direct Subsidized Loans for more than 150 percent of the published length of a program. A two year associate degree program has a maximum period for which a student can receive Direct Subsidized Loans of three years. This includes Direct Subsidized Loans received from another program. Visit <https://studentaid.gov/understand-aid/types/loans/interest-rates> for more details.

Student Employment

Federal Work-Study Program

The Federal Work-Study Program (FWS) provides funding for campus jobs for students who demonstrate financial need. Students may work up to 19 hours per week. Interested students must complete an application for financial aid prior to being employed as a FWS student. All students interested in participating in the FWS for this year must first apply for the Federal Pell Grant and have received an award letter from the Victoria College Financial Aid Office. Applications for employment in the FWS Program are available in the Human Resources Office.

Student Assistant Employment Program

A limited amount of institutional funds are available for employing individuals who are not eligible for the Federal Work-Study Program. Students are encouraged to apply for the Student Assistant Employment Program as soon as possible. International students on an F-1 visa must meet with the Primary Designated School Official (PDSO) before applying for student employment. Please contact Human Resources for more information.

Satisfactory Academic Progress (SAP) Policy

Federal regulations mandate a student receiving financial assistance under Title IV programs must maintain satisfactory academic progress in his/her course of study regardless of whether or not financial aid is awarded each semester. Title IV funds include Pell Grant, SEOG, Direct Loans, and Federal Work Study.

Financial Aid SAP standards are not the same as the Victoria College Academic Standards.

Although students may be granted an Academic Fresh Start, the Financial Aid Office is required to include all prior credits completed or attempted, including prior grade point averages (GPA), when determining eligibility for financial aid. Student financial aid, as defined in this policy, specifically applies to all federal, state, and certain institutional aid programs. Federal guidelines stipulate that this policy applies to ALL enrollment periods, regardless of whether students have received financial aid.

NECESSARY REQUIREMENTS FOR SATISFACTORY ACADEMIC PROGRESS

Qualitative Standards – Students will be expected to maintain the minimum academic standards as outlined in the Academic Regulations in the *Victoria College Catalog* and established by the Admissions & Records Office. Students must maintain a cumulative GPA of at least 2.0. This will not include any developmental classes.

Quantitative Standard – Students must complete 67% of their cumulative attempted hours. This number will not be rounded up or down. The quantitative standard is used to measure a student's pace in a program. A student may be on pace for the semester but not be on pace when calculating the cumulative hours. Pace is measured by dividing the cumulative number of hours the student has successfully completed by the cumulative number of hours the student has attempted. Keep in mind attempted means all the hours a student registered for, even those for which he/she may have received any of the following grades: W, F, FX, S, SA, SB, SC, T, U, UD, UF, I and Q. Completed means those hours for which a student has registered and received a grade sufficient for graduation. Developmental coursework is included in this calculation as well as transfer credits accepted by Victoria College.

Maximum Time Frame – Victoria College is a two year public community college with certificate and associate degree programs. Students must complete their program of study within 150% of the length of the program. Maximum time frame is measured by dividing the number of credit hours the student has attempted by the number of credit hours required to complete the student's program of study. If the student will exceed 150% by the end of the program, the student will be placed on Financial Aid suspension. The time frame requirement applies to certificate programs, as well as associate degree and applied science degrees. Transfer course work accepted by Victoria College and courses with a grade of F, FX, W, S, SA, SB, SC, T, U, UD, UF, I and Q will be included in the calculation.

Some examples of maximum time frame are:

Program Requirement Hours	Maximum Time Frame Percentage	Attempted Hours Permitted
60	150%	90
45	150%	67
32	150%	48

FAILURE TO MEET MINIMUM REQUIREMENTS

Financial Aid Warning is a status assigned to a student who fails to make Satisfactory Academic Progress at the end of a payment period and will be allowed to continue to receive aid for one payment period. There is no warning period for maximum time frame.

Financial Aid Probation is a status assigned to a student who fails to make Satisfactory Academic Progress for a subsequent payment period and

FINANCIAL AID

who has appealed and has had eligibility for aid reinstated. A student on Financial Aid Probation may receive Title IV funds for one payment period. At that point, the student must meet the school's SAP standards or the requirements of the established individual academic plan to maintain Title IV eligibility.

Financial Aid Suspension is a status assigned to a student who has not met the requirements for Satisfactory Academic Progress and has not been granted an appeal or a student who was on Financial Aid Probation and failed to meet Satisfactory Academic Progress or the requirements of the established academic plan and will not be eligible to receive Title IV funds.

APPEAL PROCESS

Students who have not made satisfactory academic progress after being placed on warning status may file an appeal to the Satisfactory Academic Progress Appeals Committee (SAPAC).

A student can appeal if:

- There is a death of a relative
- An injury or illness occurred
- Other special circumstances

How to appeal:

- Complete a SAP appeal application available at www.VictoriaCollege.edu/FinancialAidForms
- Appeal is due to the Financial Aid Office the Friday prior to the committee's meeting. The Appeals Committee meets once a month. Contact the Financial Aid Office for specific meeting dates.
- Students receiving Financial Aid awards must have their academic plan updated and current within Degree Works to receive Financial Aid funds. All enrolled courses will be evaluated against the filed degree plan and any courses recognized as not necessary will not be funded. It is encouraged that all students create a Plan of Completion with their Advisor to ensure registration within only pertinent and fundable courses. All changes must be made before the completed prior to the Official Report Date of the active semester.

If the appeal is approved:

- The student will be placed on Financial Aid Probation/PLAN.
- The student must meet the Satisfactory Academic Progress minimum requirements as outlined above.
- The student must meet the minimum requirements EVERY semester.
- The student will be evaluated at the end of each semester to determine whether he/she will continue to be eligible for Title IV funds.

If the appeal is denied:

- A student has the right to appeal to the Vice President of Student Services. The Student Appeal and Complaint Form for the Vice President of Student Services can be accessed at www.VictoriaCollege.edu/VicePresidentOfStudentServices.
- The decision made by the Vice President of Student Services is final.

ADDITIONAL INFORMATION

- Financial Aid recipients who withdraw from classes or stop attending classes before completing at least 60 percent of the semester may have to pay back a portion of their grant and/or loan money. The 60 percent completion rate will be determined by the attendance as submitted by the instructors. This is known as a Return to Title IV calculation (R2T4). This includes all grades of W, Q, U, UD, UF, F, and FX. The amount of financial aid that the student has earned up to the last attendance date is determined by a specific federal formula.
- A maximum of 30 developmental hours may be taken and paid for with Title IV funds.
- Students may not receive federal aid for courses that were previously taken and passed beyond the first retake. Repeat courses still count toward the student's attempted hours for Financial Aid purposes. Other restrictions may apply in regard to repeat courses. Check with the Financial Aid Office for clarification.
- A student on Suspension will not be eligible to receive TPEG funds for Continuing Education (CE) courses.

- Pell Lifetime Limits – the Department of Education limits the student's eligibility for Pell Grant to 600 percent or 12 full-time awards.
- Loan Aggregate Limits – the Department of Education limits loan awards based on student status: dependent/independent, undergraduate/graduate.
- A student must be in Good, Warning, or Plan status to receive institutional scholarships or childcare assistance.

Repeating Courses - Procedures

A new federal regulation limits the number of times a student may repeat a course and receive financial aid for that course (Effective July 1, 2011).

If a student gets a W, Q, F, FX, UF, or U in a course, that student is allowed to repeat the course and receive financial aid (assuming he/she is meeting Satisfactory Academic Progress) until he/she receives a D or better. Once the student has received a D grade or better, he/she can repeat the course a second time and still receive federal aid. A student is allowed one repeat after passing a course. The third time the student repeats a course in which he/she has earned a D or better, the Financial Aid Office cannot provide federal funding for that repeated course.

Listed below are a few scenarios for example purposes:

Grades Received	
D, F	If the student repeats the course a third time, that course is not eligible for aid.
F, F, D, W, F	If the student repeats the course a sixth time, that course is not eligible for aid.
F, F, D, D	If the student repeats the course a fifth time, that course is not eligible for aid.
UF, W, C, D	If the student repeats the course a fifth time, that course is not eligible for aid.

This rule applies whether or not the student received aid for earlier enrollments in the course.

All repeated courses affect financial aid Satisfactory Academic Progress calculations. A repeated course, along with all the other attempts, must be counted as attempted credit hours. If the course replaces a previous course, such as a student retaking for a higher grade, only the included courses count in the completion ratio. All students must successfully complete 67 percent of cumulative attempted hours by the end of each term.

Veterans Benefits

Veterans are admitted on the same basis as other students. Victoria College is approved by the Texas Workforce Commission programs taken under Title 38 of the US Code. Veterans Services Certifying Officials are located in the Advising & Counseling Services Office. Students seeking veterans' educational benefits must contact a Veterans Services Academic Advisor six weeks prior to their registration period. All benefit recipients (excluding Chapter 31, 33, and Hazlewood) are **required to pay their educational costs up front**. Funding will be paid directly to students by the Department of Veterans Affairs.

Veterans Benefits and Transition Act of 2018, Section 103

For any students using VA Education Chapter 33 (Post-9/11 GI Bill®) or Chapter 31 (Vocational Rehabilitation) benefits, while payment to the institution is pending from the VA (up to 90 days), the school will not:

- Prevent their enrollment;
- Assess a late penalty fee;
- Require they secure alternative or additional funding;
- Deny their access to any resources (access to classes, libraries, or other institutional facilities) available to other students who have satisfied their tuition and fee bills to the institution.

To qualify for this provision, such students are required to:

- Produce a VA Certificate of Eligibility or an eBenefits GI Bill Statement of Benefits by the first day of class;
- Provide the school a request to be certified;
- Provide any additional information needed to properly certify the enrollment as described in the school's institutional policies.

Eligible veterans will receive monthly payments for their entitlement based on the coursework for which they enroll. Courses should be selected with care. Each course must be a requirement for graduation in the veteran's declared degree program or completion of a certificate program. A course for audit credit will not be certified for payment. Students who are enrolled in Victoria College and are certified to receive veterans' benefits are expected to earn a grade point average of 2.0 on all work attempted. Students who are enrolled for six or more semester hours and fail to make a 2.0 grade point average will be placed on scholastic probation which could affect future eligibility to receive benefits.

In addition to the academic progress, the following is also reviewed by the Department of Veterans Affairs:

- All withdrawals, enforced withdrawals, and reductions in class load will be reported to the Department of Veterans Affairs.
- Repeats of classes where D's or above were earned will not be covered for veterans' benefits.

The Montgomery GI Bill®

The Montgomery GI Bill® (Chapter 30) – Active Duty program provides up to 36 months of education benefits. These benefits may be used for degree and certificate programs, apprenticeship/on-the-job training, and correspondence courses. Developmental, deficiency, and refresher courses may be approved under certain circumstances. Generally, benefits are payable for 10 years following the student's release from active duty.

The Montgomery GI Bill® (Chapter 1606) – Selected Reserve program may be available to a student if he/she is a member of the Selected Reserve. The Selected Reserve includes the Army Reserve, Navy Reserve, Air Force Reserve, Marine Corps Reserve, Coast Guard Reserve, the Army National Guard, and the Air National Guard.

Students may use this education assistance program for degree programs, certificate or correspondence courses, cooperative training, independent study programs, or apprenticeship/on-the-job training. Developmental, refresher, and deficiency training are available under certain circumstances.

Eligibility for this program is determined by the Selected Reserve components. The student is responsible for paying tuition and fees at the time of registration. Department of Veterans Affairs makes the payment to the student for this program upon verification of enrollment certification, which must be completed each semester.

The student may be entitled to receive up to 36 months of education benefits. His/her benefit enrollment entitlement ends 10 years from the date of his/her eligibility for the program, or on the day he/she leaves the Selected Reserve.

The following documents are needed to apply for The Montgomery GI Bill® benefits:

- Copy of DD-214 for Active Duty Program
- Letter of eligibility from Selected Reserve Unit for Selected Reserve Program
- VA Form 22-1990 (Application for Veterans' Educational Benefits) or VA Form 22-1995 (Request for Change of Place of Training or Program) if the student has previously used VA benefits at another institution or has not attended for one semester
- Victoria College Veteran Benefits Certification Request Form
- All prior academic transcripts and military transcripts

GI Bill® is a registered trademark of the U.S. Department of Veterans Affairs (VA). More information about education benefits offered by VA is available at the official U.S. government Web site at <https://www.benefits.va.gov/gibill>.

Veterans' Educational Assistance Program (VEAP)

VEAP is available if the student elected to make contributions from his/her military pay to participate in this education benefit program. The government matches student contributions on a \$2 for \$1 basis. The student may use these benefits for degree, certificate, correspondence, or apprenticeship/on-the-job training programs. In certain circumstances, developmental, deficiency, and refresher courses may also be available.

Benefit entitlement is 1 – 36 months depending on the number of monthly contributions. The student has 10 years from his/her release from active duty to use VEAP benefits.

The following documents are needed to apply for VEAP benefits:

- Copy of DD-214 for Active Duty Program
- VA Form 22-1990 (Application for Veterans' Educational Benefits) or VA Form 22-1995 (Request for Change of Place of Training or Program) if the student has previously used VA benefits at another institution or has not attended for one semester
- Victoria College Veteran Benefits Certification Request Form
- All prior academic transcripts and military transcripts

Survivors and Dependents Educational Assistance Program (DEA-Chapter 35)

Dependents' Educational Assistance provides education and training opportunities to eligible dependents of certain veterans. The program offers up to 45 months of education benefits. These benefits may be used for degree and certificate programs, apprenticeship, and on-the-job training. Spouses may take a correspondence course. Developmental, deficiency, and refresher courses may be approved under certain circumstances.

The following documents are needed to apply for DEA benefits:

- Copy of DD-214 for qualifying veteran
- Copy of marriage certificate for spouse and birth certificate for children
- VA Form 22-5490 (Application for Veterans' Educational Benefits) or VA Form 22-5495 or VA Form 22-5495w (Request for Change of Place of Training or Program) if the student has previously used VA benefits at another institution or have not attended for one semester
- Victoria College Veteran Benefits Certification Request Form
- All prior academic transcripts

Hazlewood Act

Students interested in using Hazlewood benefits for registration are recommended to contact the VA Academic Advisor at Victoria College at least six weeks prior to their initial registration.

The Hazlewood Act information sheets and applications are available in the Advising & Counseling Services Office. Each Hazlewood Application must be completed before each new term registration. The Hazlewood Act provides a tuition waiver, so it must be used at the time of registration. It will not be retroactively applied.

The following documents are needed to apply for the Hazelwood Act benefits:

- Hazlewood Application
- Victoria College Veteran Benefits Certification Request Form
- Copy of the DD-214
- Certificate of Eligibility for GI Benefits

Veterans' Work-Study Program

Eligible veterans can apply for this benefit by contacting the Admissions & Records Office and filling out an application for Veterans' Work-Study. Positions are limited and an interview is required.

Veterans' Vocational Rehabilitation Program (Chapter 31)

The Vocational Rehabilitation Office in Houston, Texas determines eligibility for this veterans' benefit. Information on how to contact this office can be obtained in the Admissions & Records Office.

Additional information regarding Veterans' Benefits may be obtained by visiting the VA web site at: www.gibill.va.gov.

Workforce Solutions Golden Crescent

Workforce Solutions Golden Crescent provides financial assistance (cost of tuition, fees, books, and supplies) for economically disadvantaged adults, youth, and laid-off workers. Eligibility is determined on a case-by-case basis under the program.

Workforce Solutions Golden Crescent serves people of the seven county Golden Crescent region that includes Calhoun, DeWitt, Goliad, Gonzales, Jackson, Lavaca, and Victoria counties. Persons who reside in this service area should call (361) 578-0341 or write for more information:

Workforce Solutions Golden Crescent

120 S. Main Street, Suite 110
Victoria, TX 77901

Persons who reside outside of these counties should go to the nearest Workforce Center office, or consult the website at GCWorkforce.org.

Texas Workforce Solutions Vocational Rehabilitation Services

The Texas Workforce Solutions Vocational Rehabilitation Services assists eligible consumers with tuition and required nonrefundable fees when it is deemed necessary to achieve a vocational outcome. Eligibility is based on physical or mental disabilities that create severe impediments to employment. Applications for such assistance should be made to:

Texas Workforce Solutions Vocational Rehabilitation Services

120 S. Main Street, Suite 110
Victoria, TX 77901
361-578-0341 (Option 2)
361-237-3045 (fax)

(This page left blank intentionally)

Student Services

Student Services

Student Services is comprised of various offices that provide programs, services, and resources to promote a positive campus environment focused on enhancing student development and supporting learning. For the most up-to-date information, refer to the Victoria College website at www.VictoriaCollege.edu.

Admissions & Records and Welcome Center

Student Services Building, Room 107

(361) 485-6841

Admissions@VictoriaCollege.edu

www.VictoriaCollege.edu/AdmissionsRecords

The Admissions & Records Office and the Welcome Center provide services regarding admissions to Victoria College and the management of student information and academic records:

- Admissions information
- Credit by exam
- Grade information
- Graduation
- Noncredit & testing information
- Residency determination
- Transcript requests
- Student information changes (name, address, etc.)
- Verification of enrollment & graduation

Victoria College has identified Madelyne Tolliver and Brittani Cervantez to serve as foster care liaisons for students formerly in the conservatorship of the Texas Department of Family and Protective Services (DFPS) under Texas Education Code (TEC) section 51.9356. The foster care liaisons serve a critical role in bridging the gap between the students who want to pursue a college education and those who have the support needed to complete their degree.

Foster Care Liaisons

1. Provide information to foster care alumni regarding support services.
2. Inform foster care alumni of the resources available at Victoria College.
3. Provide any other relevant information to assist foster care alumni with meeting their educational goals.

Advising & Counseling Services

Student Services Building, Room 105

(361) 582-2400

AdvisorHelp@VictoriaCollege.edu

www.VictoriaCollege.edu/AdvisingCounselingServices

Advising & Counseling Services provides quality services to students in the areas of career counseling, academic advising, transfer planning, mental health counseling, veterans advising, services for students with disabilities, and support services for non-academic issues such as food and clothing needs.

Students are encouraged to become acquainted with the Advising & Counseling Services staff to take advantage of all available resources. These services are available to all currently enrolled students. This department is responsible for providing information regarding:

- Academic advising
- Career preparation
- Clothing closet
- Disability services
- Food pantry
- Mental health counseling
- Support services
- Transfer planning
- Veterans services

Additional Advising & Counseling Services:

Career Services

Student Services Building, Room 105

(361) 573-3291 ext. 3207

www.VictoriaCollege.edu/CareerServices

The goal of Career Services is to educate and assist students with decisions regarding their career and options available to them at Victoria College.

Students can receive assistance with:

- Exploring career options
- Deciding on a career
- Revising resumes and cover letters
- Preparing for interviews
- Job searching platform—Handshake

Victoria College also offers opportunities for employers such as:

- Recruitment events on campus
- Job shadowing, internships, and apprenticeship partnerships
- Annual career fair
- Job posting platform—Handshake

Counseling Services

Student Services Building, Room 102

(361) 582-2431

AdvisorHelp@VictoriaCollege.edu

www.VictoriaCollege.edu/CounselingServices

Victoria College strives to assist students by minimizing educational hurdles while maximizing personal development and success through a variety of student services. Counseling services are provided to our students in a private and confidential environment by a licensed counselor on a short-term basis for a variety of issues.

Victoria College's Counseling Services offer free mental health counseling by a licensed counselor to all currently enrolled students. A licensed counselor is a person that has the education and real-life experience to address mental or emotional distress for students.

These issues may include:

- Anxiety
- Chemical dependency
- Depression
- Family or relationship issues
- Grief and loss
- Other personal or college-related issues
- Eating disorders

Students who need long-term counseling or whose issues extend beyond the scope of the VC Counseling staff will be referred to an outside agency within the community. All costs incurred by referrals are the responsibility of the student. Victoria College and the Counseling staff are dedicated to students and their success.

STUDENT SERVICES

Disability Services

Student Services Building, Room 105
Disability Support Services (DSS)
Disability Support Specialist, Karen Friedel
(361) 572-6411
Karen.Friedel@VictoriaCollege.edu

Section 504/ADA Coordinator, Terri Kurtz
(361) 582-2459
Terri.Kurtz@VictoriaCollege.edu

www.VictoriaCollege.edu/DisabilityServices

Disability support services are arranged on an individual case-by-case basis for qualified students with a documented disability. Services may include:

- Information and referrals
- Note-taking assistance
- Reader services
- Special equipment and equipment adaptation
- Special parking provisions
- Testing accommodations

Prospective students who may qualify should contact Advising & Counseling Services at (361) 572-6411 at least one month prior to registration. Supporting documentation may be required. The Disability Support Services Student Handbook is available in the Advising & Counseling Services Office or at www.VictoriaCollege.edu/DisabilityServices. Students with disabilities who feel that their rights have been violated have the right to file a grievance. The procedure for doing so is outlined in the *Disability Support Services Student Handbook*.

Support Services

Student Services Building, Room 103A
(361) 582-2452
AdvisorHelp@VictoriaCollege.edu
www.VictoriaCollege.edu/SupportServices

The Advising & Counseling Services staff provides and coordinates non-academic student support services in an effort to assist students in completing their academic and professional goals.

The following services may be available, either on campus or through community partnerships:

- Assistance with application for federal programs (ACP, SNAP, TANF, WIC)
- Childcare assistance
- Citizens Convenient Care at Victoria College
- Clothing closet/ clothing vouchers
- Food pantry - JP's Market/food bank
- Foster care information
- Health, vision, dental, medication referral assistance
- Housing & utilities
- Mental health counseling referrals
- Personal hygiene resources
- Transportation assistance or referrals

Please note: Some services may have an associated cost.

CARE Team

The Campus Assessment Response and Education (CARE) Team engages in proactive and collaborative approaches to identify, assess, and mitigate risks associated with students exhibiting concerning behaviors or thoughts. The Victoria College CARE Team respects the autonomy of the campus community but also takes actions to preserve students' individual rights by intervening in the least intrusive manner in the presence of safety concerns. Finally, the safety of the campus community is a responsibility shared by CARE Team and all members of the Victoria College campus community.

Veterans Services

Student Services Building, Room 105
(361) 573-3291 ext 3207
Fax: (361) 582-2525
www.VictoriaCollege.edu/VeteransServices

Veterans Services is located in the Advising & Counseling Services Office in the Student Services Building. Victoria College is approved by the Texas Workforce Commission programs under Title 38 of the U. S. Code to train veterans for degree and certificate programs. Veterans' benefits are described in detail on page 66.

Veterans Resource Connection: Johnson Hall, Room 102

In a continued effort to support veterans and their dependents, Victoria College established the Veterans Resource Connection. Services provided in the Veterans Resource Connection include:

- Referral to veteran-specific community services to support civilian transition
- Workshops focused on career selection and degree planning, financial aid assistance, and transfer processes to support student success at Victoria College and beyond.
- Available meeting space for veteran clubs, initiatives, and community building efforts.
- Free laptop usage and available study space.
- Lounge area with entertainment options and access to amenities such as a microwave, refrigerator, and coffee maker.

Enrollment Services

Student Services Building, Room 106
(361) 582-2400
EnrollmentServices@VictoriaCollege.edu
www.VictoriaCollege.edu/EnrollmentServices

Enrollment Services is responsible for providing the following services:

- Information and assistance with admissions and financial aid forms for prospective students
- Classroom presentations at elementary, middle, and high schools
- Programs to assist students with college preparation
- Campus tours
- Informational booths and presentations at community events, organizations, and businesses
- Dual Credit /Early Admissions information

Enrollment provides college information and outreach services to all prospective students.

Financial Aid Office

Student Services Building, Room 108
(361) 572-6415
FinancialAid@VictoriaCollege.edu
www.VictoriaCollege.edu/FinancialAid

Students who need help paying for college are encouraged to visit the Financial Aid Office. The Financial Aid staff will make every effort to assist students in obtaining the necessary funds to attend college. A variety of federal and state funds are available to qualifying students.

Steps for obtaining financial aid include:

- Apply for admissions
- Complete a Free Application for Federal Student Aid at <https://studentaid.gov/>
- Supply additional documentation if selected for verification
- Submit an official high school transcript with graduation date to the Admissions & Records Office
- Receive financial aid award notification
- Log in to the Pirate Portal and accept the terms and conditions for the financial aid award.

Scholarships and grants can be used for tuition, fees, books, and supplies. If loan funds will be required, an additional form can be obtained from the Financial Aid Office. When the file is processed, the student can use the loan funds for tuition, fees, books, and supplies.

STUDENT SERVICES

Child Care Assistance

Student Services Building, Room 108
(361) 572-6415
FinancialAid@VictoriaCollege.edu
www.VictoriaCollege.edu/ChildcareAssistance

To apply for assistance with child care costs, students must:

- Apply every academic year to be considered for child care assistance.
- Have completed the Victoria College financial aid process.

Information and applications for the academic year are available in the Financial Aid Office. Assistance is based on the availability of Victoria College funds, student financial need, individual student assessment, program of study, and number of hours.

Victoria College and The YMCA of the Golden Crescent have teamed up to offer discounted childcare to Victoria College students. For more information, please contact the YMCA at (361) 575-0511.

KEY Center- Student Support Services

Johnson Hall, Room 101
(361) 582-2414
KEY@VictoriaCollege.edu
www.VictoriaCollege.edu/KeyCenter

KEY stands for Knowledge, Exploration, and You — these will be the “keys” that unlock great opportunities for a Victoria College student’s education and life. The goal of the KEY Center, a Federal TRIO program, is to retain, motivate, and graduate income-eligible, first generation students, and/or students with disabilities. The mission of the KEY Center is to promote participation in postsecondary education by providing an academically enriching and supportive environment that encourages intellectual growth and social development for qualified individuals.

The services provided by the KEY Center include:

- Academic advising and degree planning
- Career counseling and exploration through job shadowing, career planning, and other resources
- Computer and study area designated for KEY Center members
- Financial Aid Assistance to help guide students through steps to secure grants and scholarships
- Financial literacy programs to empower students with information on money management
- Mentoring program pairing a student with a VC faculty, staff, or student to help establish a solid support system
- Resources and equipment for successful study habits
- Transfer assistance for students who plan to continue their education beyond Victoria College
- Tutoring program designated for KEY Center members which includes individual and group assistance

Payments Office

Student Services Building, Room 104
(361) 485-6840
Payments@VictoriaCollege.edu
www.VictoriaCollege.edu/Payments

The Payments Office is responsible for providing the following services:

- Payments
- Test registration & payments
- Payment plans
- Student identification cards

Testing Center

Continuing Education Center, Room 202
(361) 582-2589
TestingCenter@VictoriaCollege.edu
www.VictoriaCollege.edu/TestingCenter

The Testing Center provides academic skills assessment and testing for online courses and administers selected licensure and/or certification examinations. Special testing accommodations are available for students who meet eligibility criteria.

Information on testing times are available at
www.VictoriaCollege.edu/TestingCenter.

Please contact the Testing Center if additional information is needed.

Victoria College is a testing center for the following:

- ACT
- ALEKS
- ATI TEAS
- CLEP
- Correspondence Exams
- Departmental Exams
- DSST Credit By Exam
- GED
- PearsonVUE IT bundle (Amazon Web Services, Cisco, Microsoft, Oracle, etc.)
- SAT
- TCOLE Testing
- TCFP Certification
- Testing for Online Courses
- TExES Certification
- TSI Assessment 2.0 (TSIA2)

ASE Certification Testing is being offered at VC’s Emerging Technology Complex. For more details, call (361) 582-2528.

Student Life & Student Success Center (under construction)

VC Library, Basement
(361) 485-6838
StudentLife@VictoriaCollege.edu
www.VictoriaCollege.edu/StudentLife

Campus student activities are designed to:

- Give the students the opportunity for self-expression
- Increase interest in academic courses
- Provide recreation

Amenities provided to students include:

- Board Games
- Football
- Frisbee
- Giant Jenga
- Horseshoes
- Ping Pong
- Pool
- Wii
- X-Box
- Yard-size Dominoes
- Yard-size Yahtzee

These are all available in the Student Life Office located in the Library Building, Basement. A valid driver’s license or state issued ID is required to check out items.

Clubs and Student Organizations

The Student Life Office in the Library Building, Basement is the central location for information concerning campus organizations. All students are invited to visit the Student Life Office website at www.VictoriaCollege.edu/StudentLife or to stop by the office and pick up a current listing of campus organizations and decide which club or organizations best suit their interests.

Club Membership Information

To be a member of an officially sanctioned extracurricular organization in the student life of Victoria College, an individual must be registered in good standing as a student in the College. Specific prerequisites for membership and holding office are determined by the constitution and bylaws of the organization, which have been approved by the Vice President of Student Services, Student Life Committee, and the Student Life Director of Victoria College. Copies of each organization's constitution are maintained in the Student Life Office.

Phi Theta Kappa

The Zeta Gamma Chapter of Phi Theta Kappa, the national honorary scholarship society for junior colleges, was chartered in February 1947. The purposes of the society are to promote scholarship, develop character, and cultivate fellowship among the students of the junior colleges of the United States. Each semester, a faculty advisor and the registrar survey all available candidates and recommend for membership those students whose grade point average indicates superior scholastic achievement (grade point average of 3.50 or higher on 12 or more hours of associate degree coursework), who have demonstrated qualities of leadership and integrity, and are pursuing an associate or higher degree. To graduate with the Phi Theta Kappa honors, students must maintain a 3.0 cumulative GPA.

National Society of Leadership and Success (NSLS)

The NSLS is the nation's largest leadership honor society. Students are selected by their college for membership based on either academic standing or leadership potential. Candidacy is a nationally recognized achievement of honorable distinction.

In addition to honorable distinction, the NSLS provides a step-by-step program for members to build their leadership skills through participation at their campus or online. Upon completion of the program, members receive their leadership certificate and take their place among the top student leaders at their campus and across the country. Members are able to list their affiliation on all statements of personal accomplishment, including their resume.

Membership provides access to benefits including scholarships and awards, exclusive on-campus events, employer recruitment through an online job bank and discounts on computers, textbooks, grad school prep courses, insurance and much more. Each semester, invitations are sent out to students with a grade point average of 2.75 or higher and 6-36 credit hours.

Student Government

Victoria College's Student Government Association (SGA) is an elected body whose purpose is to represent the entire student body in all aspects of student life. The Student Life Director serves as an advisor to the Association. The primary responsibilities of the Association are to conduct a student body election, plan student activities, and be involved in issues concerning the welfare of the students.

Role in Institutional Decision Making

The Student Government Association serves as the official liaison between the student body and college administration. It serves as the mechanism for student participation in institutional decision making. Please see the *Victoria College Student Handbook* for a complete description of the role of the Student Government Association.

Officers and Club Representatives

To be eligible for an officer position, a student must have attended VC for one semester and completed 12 hours, except two of the four at-large representatives, who may have less than 12 hours. In addition, one representative from each official campus club or organization shall select a Student Government Representative at the beginning of the school year. The club representative may be a freshman or a sophomore.

Student Resources

Student Computer Access

Victoria College provides computers for student use and offers a variety of computer network capabilities, including Internet access, email, and a wide selection of applications.

There are several computer labs located across the campus:

- Health Sciences Center
- Johnson Hall - Learning Labs
- Technology Center
- Library Building, 2nd Floor

These buildings offer wireless network access:

- Academic Building
- Allied Health Building
- Betsy Wright Building
- College Services & Training Building
- Continuing Education Center
- Fine Arts Building
- Health Sciences Center
- Johnson Hall
- Language Building
- Sports Center
- Student Services Building
- Student Success Center (under construction)
- Technology Center
- William Wood Building

Each student is automatically issued an email address. Students can access their login and password for the Pirate Portal at <https://HelpDesk.VictoriaCollege.edu/Bansam/>. Information concerning email access and student computer support may be obtained by contacting the Help Desk at HelpDesk@VictoriaCollege.edu or (361) 582-2509.

Student Identification Cards & Badges

General use identification (ID): To obtain a student ID to use at campus events, in the Testing Center, Library, Sports Center, and Bookstore, and to receive discounts at local establishments, students should take their ~~tuition receipt~~ and photo ID to the Payments Office in the Student Services Building. ID cards must be re-validated each semester.

Special Admission Program Badges: Students enrolled in the Law Enforcement Academy, Emergency Medical Services, Vocational Nursing, Associate Degree Nursing, Physical Therapist Assistant, and Respiratory Care programs and those taking continuing education allied health-related courses should take their ~~tuition receipt~~ and photo ID to the Allied Health Building, Room 100 to obtain a student badge. Badges must be re-validated every academic year.

To replace an ID or badge, students will be charged a Card Replacement Fee of \$5.00.

STUDENT SERVICES

Success Coaching

Johnson Hall, Room 100
(361) 582-2438
www.VictoriaCollege.edu/SuccessCoaching

In Success Coaching, students and coaches develop working relationships through scheduled meetings or the Student Success Course (SDEV 0012). Coaches use a variety of tools to help students improve their time management, study strategies, focus, and motivation.

Success coaches provide the following services to students:

- Help facilitate a successful transition to Victoria College
- Help students establish priorities and set goals
- Demonstrate various study strategies
- Demonstrate strategies for organizational management
- Encourage use of daily schedules and routines
- Support students through various decision-making processes
- Increase awareness of procrastination and identify ways to get back on track
- Identify strategies for breaking down projects into manageable and achievable tasks
- Assist with exam preparation and test-taking strategies
- Introduce campus resources

Success Coaching is a requirement for all Victoria College students who are on academic warning, academic probation, or academic suspension.

To find out more information and sign up for success coaching, please call (361) 582-2438 or stop by Johnson Hall suite 100. Walk-ins are welcome.

Learning Labs

(361) 572-6473
LearningLab@VictoriaCollege.edu
www.VictoriaCollege.edu/BELL

Mathematics & Accounting Lab

Johnson Hall, Room 208

Humanities Lab

Johnson Hall, Room 106

Science Lab

Health Sciences Center, Room 116

Gonzales Center, Room 100B

Reading Room

Johnson Hall, Room 104

Learning Assistance Sessions

Learning assistance sessions are designed to promote a supportive environment by providing Learning Assistants (LAs) and a variety of resources to help students meet their educational goals.

Schedules are posted in the centers and online at www.VictoriaCollege.edu/BELL. The Learning Labs offer face-to-face and virtual assistance. Additional resources include computers and printers, copy machines in Johnson Hall, Room 106, handouts, textbooks, and an online Treasure Trove, which provides videos and downloadable handouts to students needing assistance after hours or to students unable to come to campus. Students who wish to work as LAs are encouraged to apply early each semester for these paid positions.

For additional information, please contact the Learning Lab by phone or email. LAs must have two instructor's recommendation and achieve College Reading and Learning Association (CRLA) Certification in the first two semesters they assist to ensure the quality of support services offered.

Code of Student Conduct

The Code of Student Conduct is reviewed annually and is updated as required. Updates to the Code of Student Conduct are published annually in the *Victoria College Student Handbook*. Students are subject to the most current Code of Student Conduct as printed in the *Handbook*, which may or may not be identical to the Code in this catalog.

Programs of Study

Credit Offerings

Business Management
 Criminal Justice
 Electronics Technology
 Emergency Medical Services
 Instrumentation
 Network Engineering Technology and Cloud Computing
 Nursing (Associate Degree and Vocational)
 Physical Therapist Assistant
 Process Technology
 Respiratory Care
 Welding

Degrees & Certificates

Two-Year Associate of Applied Science Degrees

Business Management
 Criminal Justice – Law Enforcement
 Electronics Technology/Instrumentation-Electronics Technology Specialization
 Electronics Technology/Instrumentation-Instrumentation Technician Specialization
 Emergency Medical Services
 Network Engineering Technology and Cloud Computing
 Nursing
 Physical Therapist Assistant
 Process Technology
 Respiratory Care

Certificates (Indicates Level 1 Certificate)*

Advanced EMT
 Basic Peace Officer*
 Cloud Core Technology*
 Electronics Technology/Instrumentation-Instrumentation*
 Instrumentation/Measurement Technician*
 Office Management*
 Paramedic
 Personal Computer & Local Area Network Support Technician*
 Process Technology*
 Vocational Nursing
 Welding – Basic*
 Welding – Advanced*

Occupational Skills Awards

Accounting Technician
 Business Relationship
 Cisco Networking Associate Technology
 IT Support Specialist
 LAN Administration
 Office Support Staff
 Project Management
 Welding

NOTE: All programs of study are subject to change. Please refer to the Victoria College website at VictoriaCollege.edu for current programs of study.

Business Management

The Business Management Program will prepare the student for a variety of entry-level management positions or entry into business training programs and will provide educational and career mobility for those students already employed in business and/or industry. For more information, call (361) 582-2579.

Degree

Associate of Applied Science Degree

Total credit hours: 60

Students who successfully complete the freshman and sophomore years of the program may apply for an Associate of Applied Science degree.

Certificates

Office Management Level 1 Certificate

Total credit hours: 15

Students who successfully complete this certificate will use business communications and technology to demonstrate understanding of the multiple elements of a business environment and effective procedures.

Block Schedule is available for students pursuing the Level 1 Office Management Certificate.

Accounting Technician Occupational Skills Award

Total credit hours: 9

Students who successfully complete this certificate will employ and demonstrate generally accepted accounting principles and internal controls when conducting general accounting and payroll processes using a manual or computerized accounting system.

Business Relationship Occupational Skills Award

Total credit hours: 9

Students who successfully complete this certificate will employ and demonstrate generally accepted interpersonal skills, team dynamics, and leadership in a business environment.

Office Support Staff Occupational Skills Award

Total credit hours: 9

Students who successfully complete this certificate will employ and demonstrate generally accepted accounting, management, team dynamics, and software operations principles in an office environment.

Business Management

Associate of Applied Science Degree

Accounting Technician Occup. Skills Award ²	Business Relationship Occup. Skills Award	Office Support Staff Occup. Skills Award	Project Management Occup. Skills Award	Office Management Level 1 Certificate ³
X		X		X
		X ⁴⁵	X ⁴⁵	X
	X	X	X	X
	X			X
	X			X

Freshman Year		
Fall Semester		
ACNT 1303 or ACCT 2301	Introduction to Accounting I Principles of Financial Accounting	3
BCIS 1305 or ITSC 1309 or COSC 1301	Business Computer Applications Integrated Software Applications Introduction to Computing	3
BMGT 1327*	Principles of Management	3
BMGT 1307	Team Building	3
EDUC 1300	Learning Frameworks	3

Spring Semester		
MATH 1324 ¹	Mathematics for Business & Social Sciences	3
ACCT 2301 or ACCT 2302	Principles of Financial Accounting Principles of Managerial Accounting	3
ENGL 2311	Technical Writing	3
BUSI 1301	Business Principles	3
Creative Arts or Language, Philosophy & Culture Elective from Core Curriculum		3

Sophomore Year		
Fall Semester		
ACNT 1329	Payroll & Business Tax Accounting	3
MRKG 1311	Principles of Marketing	3
BMGT 1309	Information and Project Management	3
BUSI 2301	Business Law	3
ECON 2301 or ECON 2302	Principles of Economics (Macro) Principles of Economics (Micro)	3

X				
			X	

Spring Semester		
ACNT 1311	Introduction to Computerized Accounting	3
BMGT 1341	Business Ethics	3
BMGT 2303*	Problem Solving and Decision Making	3
BUSG 1307	Entrepreneurship & Economic Development	3
BUSG 1303	Principles of Finance	3

X				

¹ Any higher level math elective from the core curriculum is accepted - MATH 1324 preferred

² Accounting Technician Occupational Skills Award with ACNT 1303 is TSI Exempt.

³ Office Management Level 1 certificate with ACNT 1303 and ITSC 1309 is TSI Exempt.

⁴ Student can choose to take ITSC 1309 or BCIS 1305 or COSC 1301.

⁵ Office Support Staff and Project Management Occupational Skills Awards with ITSC 1309 is TSI Exempt.

* Capstone course

Criminal Justice

The Criminal Justice Program at Victoria College prepares students for a career in the law enforcement field. The Program provides learning opportunities which introduce, develop, and reinforce academic and occupational knowledge, skills, and attitudes required for job acquisition, retention, and career advancement. Victoria College offers both a Basic Peace Officer Certification Course, as well as an Associate of Applied Science Degree in Criminal Justice-Law Enforcement.

Program curriculum, course identifications, titles, and descriptions are subject to change with approval of the Texas Higher Education Coordinating Board. For current curriculum or more information, visit VictoriaCollege.edu, or contact the Criminal Justice Program Office at (361) 572-6426.

Degree

Associate of Applied Science Degree

Total credit hours: 60

The Associate of Applied Science Degree in Criminal Justice-Law Enforcement is designed to provide students with foundational skills in law enforcement. The degree also serves law enforcement professionals seeking enhanced skills and a broad spectrum of knowledge in the field of criminal justice.

Admission Requirements

1. The student must meet the admission requirements for Victoria College as stated in the current College catalog, to include high school and all college transcripts. Contact Admissions & Records Office for more information.
2. TSI (Texas Success Initiative) must be satisfied. Contact Admissions & Records Office for more information.
3. Overall GPA of 2.0 or above on all college hours attempted.
4. Must meet the requirements for the Basic Peace Officer course.

Certificate

Police Academy Certificate “Continuing Education Program”

Total credit hours: 0

The Certificate Program was developed to prepare students for a career as a Texas Peace Officer. The Victoria College Law Enforcement Academy meets the curriculum requirements for certification as a Basic Peace Officer from the Texas Commission on Law Enforcement (TCOLE). Students who successfully complete the program will be eligible to take the TCOLE licensing exam.

Admission Requirements

The Law Enforcement Academy is a selective admission program with a maximum enrollment of 24 students. The following are the minimum requirements to be qualified for admission into the program.

1. Meet the admission requirements for Victoria College as stated in the current College catalog. Contact Admissions & Records Office for more information.
2. Meet the minimum reading, writing and math requirement on the National Police Officer Selection Test (POST).
3. Complete the Law Enforcement Academy Program application.
4. Satisfactory completion of the physical fitness test, psychological exam, physical exam, and criminal history check.
5. Provide a copy of driver license record (Type 3A).
6. Interview with the Law Enforcement Academy Director.

Criminal Justice-Law Enforcement

Associate of Applied Science Degree

Summer Session		
SDEV 0301 ¹	Learning Frameworks	0

Freshman Year		
Fall Semester ²		
CJLE 1506*	Basic Peace Officer I	5
CJLE 1512*	Basic Peace Officer II	5
CJLE 1518*	Basic Peace Officer III	5
CJLE 1524*	Basic Peace Officer IV	5
CJLE 1329*	Basic Peace Officer V	3
CJLE 1132*	Physical Fitness for Law Enforcement	1

Spring Semester		
CRIJ 1301	Introduction to Criminal Justice	3
CRIJ 2313	Correctional Systems & Practices	3
ENGL 1301	Composition I	3

Sophomore Year		
Fall Semester		
GOVT 2305	Federal Government	3
CRIJ 2314	Criminal Investigation	3
CRIJ 1310	Fundamentals of Criminal Law	3
MATH Elective from Core Curriculum		3
Language, Philosophy & Culture/Creative Arts Elective from Core Curriculum		3

Spring Semester		
CRIJ 1306	Court Systems and Practices	3
CRIJ 2328 ⁺	Police Systems and Practices	3
DAAC 1317	Basic Counseling Skills	3
ENGL 2311	Technical Writing	3

Police Academy Certificate

X
X
X
X
X
X
X

WORK/LIFE EXPERIENCE POLICY

The Criminal Justice Program has developed the following mechanism to assist those persons employed in the criminal justice field to satisfy degree requirements for their work/life experience and in-service training.

Students who wish to obtain an Applied Science Degree in Criminal Justice-Law Enforcement from Victoria College and are certified peace officers from the Texas Commission on Law Enforcement (TCOLE) may satisfy degree requirements for Basic Peace Officer courses by meeting the following criteria. Students must have taken and successfully completed 15 hours of general education courses that are included in the Texas core curriculum from Victoria College prior to receiving credit for the Peace Officer courses. Director of Public Services Academies approval is required for permission to satisfy degree requirements in this manner.

The prerequisites for work/life and in-service training credit are as follows:

1. The applicant must be currently employed with a criminal justice agency and have at least six months experience, and
2. The applicant must submit a résumé and all supporting documentation to the program coordinator for evaluation, and
3. The applicant must secure a letter of verification from the chief administrator of the employing agency attesting to the information contained in the applicant's résumé and supporting documentation regarding the prerequisites and criteria required by this policy.

Credit	Noncredit		
CJLE 1506	CJLE 1006	Basic Peace Officer I	5
CJLE 1512	CJLE 1012	Basic Peace Officer II	5
CJLE 1518	CJLE 1018	Basic Peace Officer III	5
CJLE 1524	CJLE 1024	Basic Peace Officer IV	5
CJLE 1329	CJLE 1029	Basic Peace Officer V	3
CJLE 1132	CJLE 1032	Physical Fitness for Law Enforcement	1

¹ Required for all first-time-in-college students. EDUC 1300 may be substituted for SDEV 0301.

² Fall Semester can be taken anytime during the degree plan, as long as the attendee is 21 years of age upon completion of the Academy. Please see Program Director for more information.

*May be taken as noncredit CJLE 1006, CJLE 1012, CJLE 1018, CJLE 1024, CJLE 1029, and CJLE 1032-See Work/Life Experience Policy

⁺ Capstone course

Electronics Technology/Instrumentation

ELECTRONICS TECHNOLOGY SPECIALIZATION

This program of study is designed to provide a certificate of completion or associate degree with the knowledge and skills necessary for a graduate to pursue entry-level positions as an electronics technician. Electronics technicians install, maintain, troubleshoot, repair, and replace electronic equipment to maintain quality products and ensure environmental protection, safety, and cost-effective operations. They may work in a variety of industries, such as manufacturing, radio & television, medical equipment, research and development, and many others.

Degree

Associate of Applied Science Degree – Electronics Technology

Total credit hours: 60

Students who successfully complete the freshman and sophomore years of the program may apply for an Associate of Applied Science degree.

INSTRUMENTATION SPECIALIZATION

This program of study is designed to provide a certificate of completion or associate degree with the knowledge and skills necessary for a graduate to pursue entry-level positions as an instrumentation technician. Instrumentation and controls technicians install, maintain, troubleshoot, repair, and replace process control equipment to produce quality products and ensure environmental protection, safety, and cost-effective operations. Most instrumentation & control technicians are skilled workers that work five days a week on straight-day shifts. Instrument technicians are employed locally and globally in many types of industries, such as chemical, petrochemical, power generation, manufacturing, hospital/medical equipment, construction, and many others.

Degree

Associate of Applied Science Degree – Instrumentation

Total credit hours: 60

Students who successfully complete the freshman and sophomore years of the program may apply for an Associate of Applied Science degree.

Certificates

Instrumentation Level 1 Certificate

Total credit hours: 24

Students who successfully complete the required courses may apply for a Certificate in Instrumentation Technology.

Instrumentation/Measurement Technician Certificate

Total credit hours: 21

Block Schedule is available for students pursuing the Level 1 Instrumentation Certificate.

Program curriculum, course identifications, titles, and descriptions are subject to change and approval of the Texas Higher Education Coordinating Board. For current curriculum or more information, visit VictoriaCollege.edu, contact the Electronics Technology/Instrumentation Program Office at (361) 572-6467, or email Mark.Olsovsky@VictoriaCollege.edu.

Electronics Technology

Associate of Applied Science Degree – Electronics Technology

Summer Session		
SDEV 0301 ¹	Learning Frameworks	0
Freshman Year		
Fall Semester		
CETT 1302	Electricity Principles	3
CETT 1325	Digital Fundamentals	3
MATH 1314 ²	College Algebra	3
COSC 1315	Fundamentals of Programming	3
ENGL 2311 ³	Technical & Business Writing	3
Spring Semester		
MATH 1316 ²	Plane Trigonometry	3
COSC 1436	Programming Fundamentals I	4
CETT 1329	Solid State Devices	3
CETT 1349	Digital Systems	3
Sophomore Year		
Fall Semester		
INTC 1357	AC/DC Motor Control	3
INTC 1350	Digital Measurement and Control	3
EECT 1303	Introduction to Telecommunications	3
PHYS 1401 ⁴	College Physics I	4
SCH 1311 or SPCH 1315 or SPCH 1318	Introduction to Speech Communications	3
	Fundamentals of Public Speaking	
	Interpersonal Communication	
Spring Semester		
CETT 2339 [*]	Amplifier Analysis	3
Language, Philosophy & Culture/Creative Arts Elective from Core Curriculum		3
American History, Government/Political Science, or Social and Behavioral Sciences Elective from Core Curriculum		3
INTC 2336	Distributed Control & Programmable Logic	3
PHYS 1402 ⁴	College Physics II	4

¹ Required for all first-time-in-college students. EDUC 1300 may be substituted for SDEV 0301.

² Any higher level math elective from the core curriculum is accepted excluding MATH 1324.

³ Will accept ENGL 1301 if taken before Fall 2020

⁴ Any higher level PHYS is accepted

^{*} Capstone course

Instrumentation

Associate of Applied Science Degree – Instrumentation

Summer Session			Certificate in Instrumentation	Instrumentation/Measurement Technician Certificate
SDEV 0301 ¹	Learning Frameworks	0		
Freshman Year				
Fall Semester				
CETT 1302	Electricity Principles	3	X	X
MATH 1332 or MATH 1314 ²	Contemporary Mathematics	3		
	College Algebra			
CETT 1325	Digital Fundamentals	3	X	X
PTAC 1302	Introduction to Process Technology	3		X
ENGL 2311 ³	Technical & Business Writing	3		
Spring Semester				
CETT 1329	Solid State Devices	3	X	X
INTC 1301	Principles of Industrial Measurements I	3	X*	X*
Language, Philosophy & Culture/Creative Arts Elective from Core Curriculum		3		
American History, Government/Political Science, or Social and Behavioral Sciences Elective from Core Curriculum		3		
CETT 1349	Digital Systems	3	X	
Sophomore Year				
Fall Semester				
EECT 1303	Introduction to Telecommunications	3		
INTC 1357	AC/DC Motor Control	3		X
INTC 1343	Application of Industrial Automatic Control	3	X	
INTC 1356	Instrumentation Calibration	3		X
INTC 1350	Digital Measurement and Control	3		
Spring Semester				
CETT 2339 ⁴	Amplifier Analysis	3		
INTC 1355	Unit Operations	3	X	
INTC 2330	Instrumentation Systems Troubleshooting	3		
INTC 2336 ⁴	Distributed Control & Programmable Logic	3	X	
PHYS 1310 ⁴	Elementary Physics	3		

¹ Required for all first-time-in-college students. EDUC 1300 may be substituted for SDEV 0301.

² Will accept any mathematics from the core curriculum except MATH 1324

³ Will accept ENGL 1301 if taken before Fall 2020

⁴ Will accept PHYS 1401 and PHYS 1402

⁺ Capstone course for degree

^{*} Capstone course for certificates

Emergency Medical Services

The Emergency Medical Services (EMS) Program offers courses that lead to Emergency Medical Technician (EMT), Advanced EMT* (AEMT) (formerly EMT-Intermediate), and Paramedic certification, as well as an Associate of Applied Science degree which leads to Paramedic licensure. Certificate courses are approved by the Texas Department of State Health Services (DSHS), and students completing all requirements are eligible to seek certification, by written examination, from DSHS and the National Registry of EMTs (NREMT).

Students taking additional technical and general academic courses may earn an Associate of Applied Science (AAS) Degree in Emergency Medical Services and are eligible to apply for paramedic licensure from the Texas Department of State Health Services. When minimum entry requirements are met, admission to EMT courses is on a first-come, first-served basis. EMS is a selective-admissions program and requires a department application. Program curriculum, course identifications, titles, and descriptions are subject to change and approval of the Texas Higher Education Coordinating Board. For current curriculum or more information, visit VictoriaCollege.edu, or contact the EMS Program Coordinator at (361) 572-6447.

Degree & Certificates

Associate of Applied Science Degree

Total credit hours: 60

Students completing the entire curriculum are eligible to apply for an Associate of Applied Science Degree in Emergency Medical Services from Victoria College and are eligible to apply for Paramedic licensure from DSHS.

Paramedic Certificate

Total credit hours: 41

Students completing all required courses with a final grade of C or better are eligible to apply for a Paramedic Certificate from Victoria College and are eligible to apply for DSHS and NREMT certification as a paramedic.

Advanced EMT Certificate (formerly EMT-Intermediate)

Total credit hours: 18

Students who successfully complete this certificate for EMT, upon certification, are entry-level prehospital healthcare providers with specialized skills in advanced life support and may obtain employment with an EMS, industry, or hospital.

Admission Requirements – AAS, Paramedic Certificate & AEMT Certificates

1. The student must meet the admission requirements for Victoria College as stated in the current College catalog. Contact Admissions & Records Office for more information.
2. TSI (Texas Success Initiative) must be satisfied. Contact Advising & Counseling Services for further explanation, if necessary.
3. The student must complete an EMT assessment Challenge Exam.
4. The student must complete the Paramedic Program application.
5. The student must have validation of current EMT level knowledge by: 1) successful completion of Victoria College's EMT courses within one year of application to the Paramedic Program, 2) passing a NREMT certification exam or CE evaluation within one year of application to the Paramedic Program, or 3) scoring at least a 70% on the Victoria College EMSP challenge exam within one year of application to the Paramedic Program.
6. The student must have documentation of current EMT certification.
7. The student must submit official college transcripts indicating a grade of C or better in EMSP 1501 and EMSP 1160, or noncredit equivalent.
8. Interview with program coordinator.
9. The interview must be completed and all admission documents must be in the EMS Program office prior to the start of the program. Late applicants will be considered on a space-available basis.
10. Some clinical agencies require criminal background checks and drug screens prior to clinical learning experiences. Any student who does not have a clear criminal background check and drug screen may not be able to meet all course objectives.

Prior to enrollment, qualified applicants who have been accepted into the AEMT/Paramedic Program must meet the following requirements:

- a. Two-step TB skin test or chest x-ray
- b. Tetanus-diphtheria toxoid (TD) within the last 10 years
- c. Measles/Mumps/Rubella vaccinations or serological confirmation of immunity
- d. Varicella vaccinations or proof of disease, including serological confirmation of immunity
- e. Three injection hepatitis B vaccination series or serological confirmation of immunity to hepatitis B virus
- f. Current flu vaccine
- g. American Heart Association (AHA) Basic Life Support for Healthcare Provider certification
- h. Criminal background check and drug screen conducted by the EMS Program approved provider

PROGRAMS OF STUDY

Emergency Medical Services

Associate of Applied Science Degree

Prerequisites ¹			Paramedic Certificate	Advanced EMT Certificate
EMSP 1501	Emergency Medical Technician	5		
EMSP 1160	Clinical, Emergency Medical Technology/Technician	1	X	X
SDEV 0301 ²	Learning Frameworks	0	X	X
EMSP 2206 ³	Emergency Pharmacology	2	X	
Freshman Year				
Summer I and/or II Session ⁴				
EMSP 1438	Introduction to Advanced Practice	4	X	X
EMSP 1356	Patient Assessment & Airway Management	3	X	X
EMSP 1355	Trauma Management	3	X	X
EMSP 1261	Clinical, Emergency Medical Technology/Technician (EMT Paramedic) I	2	X	X
Fall Semester				
EMSP 2444	Cardiology	4	X	
EMSP 2434	Medical Emergencies	4	X	
EMSP 2262	Clinical, Emergency Medical Technology/Technician (EMT Paramedic) II	2	X	
EMSP 2330	Special Populations	3	X	
Spring Semester				
EMSP 2243 ⁺	Assessment Based Management	2	X	
EMSP 2305	EMS Operations	3	X	
EMSP 2363 ⁺	Clinical, EMS Capstone	3	X	
Sophomore Year				
Fall Semester				
COSC 1301 ⁵	Introduction to Computing	3		
BIOL 2404 ^{5*}	Introductory Anatomy & Physiology	4		
ENGL 1301 or ENGL 2311	Composition I or Technical & Business Writing	3		
EMSP 2352 or EMSP 2358	Emergency Medical Service Research or Critical Care Paramedic	3		
Spring Semester				
Language, Philosophy & Culture/Creative Arts Elective from Core Curriculum		3		
PSYC 2301	General Psychology	3		

CREDIT FOR NON-CREDIT COURSES

Students who wish to obtain an Associate of Applied Science Degree in EMS and are EMTs or Paramedics currently certified by the Texas Department of State Health Services or National Registry may satisfy degree requirements by meeting the following criteria and successfully completing 15 hours of general education courses that are included in the Texas core curriculum from Victoria College prior to receiving credit for EMS courses. EMS Coordinator approval is required for permission to satisfy degree requirements in this manner.

The prerequisites for work/life and in-service training credit are as follows:

The applicant must show proof of current certification either through Texas Department of State Health Services (TDSHS) or National Registry (NR) certification, and be in good standing.

Credit for the following courses may be awarded under this policy:

EMSP 1501	Emergency Medical Technician	5
EMSP 1160	Clinical, Emergency Medical Technology/Technician	1
EMSP 2206	Emergency Pharmacology	2
EMSP 1438	Introduction to Advanced Practice	4
EMSP 1356	Patient Assessment & Airway Management	3
EMSP 1355	Trauma Management	3
EMSP 1261	Clinical, Emergency Medical Technology/Technician (EMT Paramedic) I	2
EMSP 2444	Cardiology	4
EMSP 2434	Medical Emergencies	4
EMSP 2262	Clinical, Emergency Medical Technology/Technician (EMT Paramedic) II	2
EMSP 2330	Special Populations	3
EMSP 2243	Assessment Based Management	2
EMSP 2305	EMS Operations	3
EMSP 2363	Clinical, EMS Capstone	3

¹ Courses can be taken at any time as prerequisite. Students completing EMSP 1501 and 1160 with a final grade of C or better are eligible to apply for DSHS & NREMT Certification as an EMT-Basic.

² Required for all first-time-in-college students. EDUC 1300 may be substituted for SDEV 0301.

³ EMSP 2206 is recommended for the Advanced EMT Certificate.

⁴ AEMT also offered in Spring Semester

⁵ It is recommended that these courses be completed before applying to the Paramedic Program.

⁶ Students who complete summer courses are eligible for NR-AEMT testing.

⁺ Capstone course

*Note: BIOL 2401 and BIOL 2402 are recommended instead of BIOL 2404 if student plans to pursue a higher degree.

Network Engineering Technology and Cloud Computing

The degree and certificate plans listed below prepare students for a variety of entry-level networking and information technology (IT) support jobs in the information technology field by providing job skills of installation, configuration, and support of PCs and local area networks (LAN); maintenance of PC and network hardware and software; monitoring the network to ensure availability for all system users; administration of a small to mid-sized network as well as hands-on training in new technologies such as cloud support. Students completing the AAS degree acquire a greater level of skill and instruction in areas such as cloud computing, server management, and security. The coursework emphasizes hands-on, skill-building labs and provides knowledge necessary to pass industry standard certifications, such as A+, Network+, Server+, Cloud+, Amazon Web Services (AWS) Cloud Practitioner, Fundamentals of Azure, and CCNA (Cisco Certified Network Associate), which lead to greater employment opportunities and benefits. Practice testing opportunities for the CCNA, AWS Cloud Practitioner, Fundamentals of Azure, and CompTIA A+ certification exams are provided at no cost to students enrolled in the program. This program is designed as a flex program, providing most courses in a combination of face-to-face, online, and hybrid formats to allow enrollment for working students. All courses emphasize active learning and student engagement. Information about this program can be obtained by calling (361) 572-6478.

Degree

Associate of Applied Science Degree*

Total credit hours: 60

The coursework emphasizes hands-on, skill-building labs and provides knowledge necessary to pass industry standard certifications, such as A+, Network+, Server+, Cloud+, AWS Cloud Practitioner, Fundamentals of Azure, and CCNA (Cisco Certified Network Associate), which lead to greater employment opportunities and benefits. Practice testing opportunities for the CCNA, AWS Cloud Practitioner, Fundamentals of Azure, and CompTIA A+ certification exams are provided at no cost to students enrolled in the program.

Certificates

Personal Computer & Local Area Network Technician Certificate (Level I Certificate)

Total credit hours: 27

Students who successfully complete this certificate will be prepared to work in an IT repair or helpdesk environment and will have learned the skills to complete the CompTIA A+ industry certification.

Block Schedule is available for students pursuing the Level 1 Personal Computer and Local Area Network Technician Certificate.

Cloud Core Technology Certificate (Level I Certificate)*

Total Credit hours: 24

Students who successfully complete this certificate are prepared to work in a business utilizing cloud concepts and services, including basic cloud services, hybrid cloud technology and migration to a cloud environment. Students learn hands-on skills for use in the cloud including certified AWS Cloud Practitioner training and Fundamentals of Azure training.

IT Support Specialist Occupational Skills Award

Total credit hours: 12 (offered fall semester)

Students who successfully complete this certificate will be prepared to work in an IT repair or helpdesk environment.

CISCO Networking Associate Technology Occupational Skills Award

Total credit hours: 9

Students who successfully complete this certificate will be prepared to work in a small to medium-sized networking environment and will gain the knowledge and skills required to successfully install, operate, and troubleshoot the network. As members of the Cisco Networking Academy program, students will perform extensive routing and switch configuration. Topics such as IP addressing, IP Services, LAN switching, IP routing technologies, network device security, and Wide Area Network (WAN) technologies will be covered. Students will have gained the knowledge base necessary to take certification exams to earn the Cisco CCNA certification. CCNA practice exams are available to students enrolled in the program.

LAN Administration Occupational Skills Award

Total credit hours: 12

Students who successfully complete this certificate will be prepared to work in a networking environment configuring routers, switches, Microsoft servers, and other networking devices.

Network Engineering Technology and Cloud Computing

Associate of Applied Science Degree (AAS)

Freshman Year		
Summer Session		
SDEV 0301 ¹	Learning Frameworks	0
COSC 1301 ² or ITSC 1309	Introduction to Computers (Required for students pursuing an AAS)	3
	Integrated Software Applications I (For Non-TSI Certificates and Occupational Skills Awards)	
ENGL 1301 or ENGL 2311 ³	Composition I	3
	Technical & Business Writing	

PC & LAN Support Technician Certificate (Level 1) ⁶	Cloud Core Technology Certificate (Level 1) ⁶	IT Support Specialist Occupational Skills Award	LAN Administration Occupational Skills Award	Cisco Networking Associate Technology Occupational Skills Award
X	X	X	X	X
X				

Fall Semester		
ITCC 1314	CCNA1: Introduction to Networks	3
ITSY 1342	Information Technology Security	3
ITSC 1325	Personal Computer Hardware & OS (A+)	3
ITSC 2339	Personal Computer Help Desk Support	3

X	X	X		X
X	X	X		
X		X		
X		X		

Spring Semester		
ITCC 1344	CCNA2: Switching, Routing, and Wireless Essentials	3
ITNW 2305	Network Administration (Microsoft)	3
ITSC 1316	Linux Installation and Configuration	3
ITSY 2345	Network Defense and Countermeasures	3

X				X
X	X		X	
X	X			
X				

Sophomore Year		
Summer Session		
Mathematics Elective from Core Curriculum ⁴		3
Social and Behavioral Science Elective from Core Curriculum ⁵		3

Fall Semester		
ITCC 2320	CCNA3: Enterprise Networking, Security & Automation	3
ITSE 1359	Introduction to Scripting Languages	3
ITNW 1309	Fundamentals of Cloud Computing	3
ITNW 1354	Implementing and Supporting Servers	3

				X
	X		X	
	X		X	
			X	

Spring Semester		
Creative Arts or Language, Philosophy & Culture Elective from Core Curriculum		3
ITSW 1307	Introduction to Database (MySQL)	3
ITNW 1336	Cloud Deployment & Infrastructure Management	3
ITNW 2335	Network Troubleshooting	3

	X			
	X			

Total Credit Hours: 60

¹ Required for all first-time-in-college students. EDUC 1300 may be substituted for SDEV 0301.

² COSC 1301 required for students pursuing an AAS degree

³ ENGL 2311 (will substitute ENGL 1301)

⁴ MATH 1314 preferred

⁵ PSYC 2301 preferred

⁶ No TSI Assessment requirements

Level 1 Certificates (No TSI Requirements)

PC & LAN Support Technician Certificate (Level 1)

Summer Session		
ITSC 1309	Integrated Software Applications I	3

Fall Semester		
ITCC 1314	CCNA 1: Introduction to Networks	3
ITSY 1342	Information Technology Security	3
ITSC 1325	Personal Computer Hardware & OS (A+)	3
ITSC 2339	Personal Computer Help Desk Support	3

Spring Semester		
ITCC 1344+	CCNA 2: Switching, Routing, and Wireless Essentials	3
ITNW 2305	Network Administration (Microsoft)	3
ITSC 1316	Linux Installation and Configuration	3
ITSY 2345	Network Defense and Countermeasures	3

Total Credit Hours: 27

+ Capstone course

Cloud Core Technology Certificate (Level 1)

Fall Semester		
ITCC 1314	CCNA 1: Introduction to Networks	3
ITSY 1342	Information Technology Security	3
ITSE 1359	Introduction to Scripting Languages	3
ITNW 1309	Fundamentals of Cloud Computing	3

Spring Semester		
ITNW 2305	Network Administration (Microsoft)	3
ITSC 1316	Linux Installation and Configuration	3
ITNW 1336+	Cloud Deployment & Infrastructure Management	3
ITSW 1307	Introduction to Database (MySQL)	3

Total Credit Hours: 24

+ Capstone course

Nursing-Associate Degree (Generic Student)

Victoria College offers a two-year Associate of Applied Science degree-nursing. Upon successful completion of the program, the graduate is eligible to apply to take the National Council Licensure Examination for Registered Nurses (NCLEX-RN). Satisfactory achievement on the examination will qualify the graduate for licensure as a registered nurse.

The Associate Degree Nursing (ADN) Program is fully approved by the Texas Board of Nursing and accredited by the Accreditation Commission for Education in Nursing (ACEN), 3390 Peachtree Road NE, Suite 1400, Atlanta, Georgia 30326 or call (404) 975-5000.

Degree

Associate of Applied Science Degree – Nursing

Total credit hours: 60

Admission Requirements

Admission requirements for the ADN Program differ from general admission to Victoria College. Additional information may be found at www.VictoriaCollege.edu/ProfessionalNursing. The ADN Program is a selective admission program, which accepts a limited number of students each semester. All qualified applicants will be selected based on the program point system and selection process which may be explained during the advising interview.

In order to be considered an eligible applicant, it is the responsibility of the applicant to ensure that all necessary documentation as stated below is in the ADN Office by June 1 for fall admission and by September 1 for spring admission.

1. The student must meet the admission requirements for Victoria College as stated in the current College catalog. Contact the Admissions & Records Office.
2. High school graduate via official high school transcript or General Education Development (GED) equivalency is required for admission. Submit all official transcripts to the Admissions & Records Office.
3. Completed student ADN program application dated within the last year; must also have a Victoria College student application (www.VictoriaCollege.edu/GettingStarted).
4. A complete Licensure Eligibility Question (LEQ) form must be submitted to the respective ADN Office and dated within the last year. It can take up to four months or longer for the Texas Board of Nursing (BON) to complete this process. Without resolution of all licensure eligibility issues, an applicant is not eligible for admission to the ADN Program. Once a clear Criminal Background Check (CBC) result is received from the Texas BON, it is the applicant's responsibility to submit original documentation to the respective ADN Office and also upload to the CastleBranch/ViewPoint website. A clear Texas BON CBC must be on file in the ADN Office by application deadline (faxed or scanned copies will not be accepted). The date on the document (postmark date on blue card or date on letter) cannot be more than one year old.
5. A qualifying ATI TEAS test composite score of 68% or higher to be eligible for admission to the ADN Program for the June 1, 2025 deadline. Additional points will be awarded for admission scores above a 68%. The applicant will be able to test three times in a 12-month period, with the most recent score being considered. The ATI TEAS score is good for two years from the testing date. Contact the VC Testing Center at (361) 582-2589 for further information regarding the ATI TEAS.
6. A qualifying ATI TEAS test composite score of 68% or higher is required to be eligible for admission to the ADN Program. Additional points will be awarded for admission scores above 68%. The applicant will be able to test three times in a 12-month period, with the most recent score being considered. The ATI score is good for two years from the testing date. Contact the VC Testing Center at (361) 582-2589 for further information regarding the ATI TEAS
7. TSI (Texas Success Initiative) must be satisfied. Please contact Advising & Counseling Services and the Admissions & Records Office to validate TSI status.
8. A grade of C or better by June 1 for fall applicants or by September 1st for spring applicants in each of the following prerequisite courses:
BIOL 2401 BIOL 2420 HPRS 2300 PYSC 2301
Please note: Science courses (BIOL 2402 & BIOL 2420) completed more than five years ago must be repeated. HPRS 2300 (Pharmacology) will be within three years of completion. Psychology courses (PYSC 2301 & 2314) completed more than seven years prior must be repeated.
9. Official college transcripts from all colleges or universities attended on file in Admissions & Records Office.
10. Overall GPA of 2.0 or above on all Victoria College hours attempted and GPA of 2.25 or higher in the ADN program of study. Any student whose cumulative GPA falls below 2.0 will not graduate.
11. ADN Program Advising interview is required no more than one year prior to program admission. Call (361) 572-6435 for more information.
12. Immunizations a) Measles, Mumps, and Rubella (MMR), b) Varicella (Chicken pox), c) Tetanus, Diphtheria, and Pertussis, (Tdap), and d) Hepatitis B series (takes 6 months to complete) are to be completed prior to the application deadline. Proof of serological immunity is acceptable. Prior to application deadline, the applicant will upload the required documentation into CastleBranch/ViewPoint website and ensure acceptance by CastleBranch/ViewPoint.
13. Prior to enrollment, qualified applicants who have been accepted into the ADN program must submit a) current American Heart Association Healthcare provider CPR card or a current American Heart Association or American Red Cross Healthcare Provider CPR card, b) TB screening test c) completed VC physical examination form, d) submit a 10-panel drug screen test, e) influenza vaccination (required for spring admissions only), and (f) COVID Vaccine or Exemption Status: At the discretion of the healthcare facility, proof of COVID vaccination or exemption may be required. All exemptions will be reviewed and handled on an individual basis by VC's Advising & Counseling Services office. The required documents will be uploaded by the applicant into the CastleBranch/ViewPoint website by the date indicated on the acceptance letter.
14. The second attempt of repeated course work (non-nursing courses) will count towards the nursing program admission scores. A waiver is required on second failed attempt from the ADN Program Chair.
15. Students admitted to the nursing program who are unsuccessful with any course work will be allowed only one additional opportunity. After two unsuccessful attempts, students are not eligible to apply for readmission.
16. Students who are unsuccessful in the program and/or desire to reenter the program must repeat all concurrent nursing courses for that semester. This includes successful coursework which the student received a grade of C or higher. Grade waivers will not be granted. Readmission must occur within two years of a prior admission.

Readmission and Transfer

Readmission and transfer students are considered on a space-available basis by readmission or transfer from outside the Victoria College system. Readmission must occur within two years of a prior admission. However, students can be admitted twice. Preference will be given as follows:

1. READMISSION OF PREVIOUSLY ENROLLED VICTORIA COLLEGE ADN STUDENTS

Students' course work and clinical performance will be evaluated by the ADN Program Chair. Students who wish to be considered for readmission must meet all current admission requirements as listed in the VC catalog. The student will need to meet with the ADN Program Chair to discuss all readmission criteria. The student will need to submit a letter to the program chair two months prior to the beginning of the semester that the student is considering to reenter. Any special circumstances involved in a students' withdrawal/dismissal from the program will be reviewed by the ADN Program Chair and Dean of Allied Health. Before registration, the Selection and Retention Committee will review the records and rank candidates seeking re-entry into Levels (semesters) I, II, III, IV based on the criteria in the Nursing Programs Handbook. The number of individuals selected for readmission is based on availability of seats per semester in the ADN Program. Students' coursework and clinical performance will be evaluated by the ADN program chair. Readmission students will be selected based on current GPA. Any special circumstances involved in a students' withdrawal/dismissal from the program will be reviewed by the ADN Program Chair and the Dean of Allied Health. Readmission must occur within two years of prior admission.

2. TRANSFER FROM OUTSIDE VICTORIA COLLEGE ADN SYSTEM

Transfer students are considered on a space available basis. Students who have successfully completed nursing courses at other accredited schools are evaluated on an individual basis by the ADN Program Chair to determine their entry level in the Victoria College ADN program. The transfer student must furnish a copy of each nursing course syllabus with course description to the ADN Program Chair so each course can be evaluated. Transfer students must meet the same admission and progression criteria as the Victoria College students. Completing at least 25% of the program of study including the capstone course at Victoria College is necessary to meet the requirements for graduation. It is the responsibility of the applicant to furnish all necessary documentation to the ADN office at least two months prior to the semester the student is seeking entry. Immunizations a) Measles, Mumps, and Rubella (MMR), b) Varicella (Chicken pox), c) Tetanus, Diphtheria, and Pertussis, (Tdap), and d) Hepatitis B series are to be completed prior to the application deadline. Proof of serological immunity is acceptable. Prior to acceptance, the applicant will upload documents into the CastleBranch/ViewPoint website. Prior to enrollment, qualified applicants, who have been accepted into the ADN Program must submit a) current American Heart Association American or Red Cross Healthcare Provider CPR card, b) completed VC physical examination form, and c) submit a 10-panel drug screen test, d) TB screening test, and e) COVID Vaccine or Exemption Status: At the discretion of the Healthcare facility, proof of a COVID vaccination or an exemption maybe required. All exemptions will be reviewed on an individual basis by VC's Advising & Counseling Services office. These documents will be uploaded by the applicant into the CastleBranch website. Students are allowed two attempts for the duration of the program. After two unsuccessful attempts, students are not eligible to apply. Students wishing to transfer to the VN program that are deemed eligible must make an appointment with the VC ADN and VN Program Chair.

Nursing-Associate Degree

(Generic Student Curriculum)

Associate of Applied Science Degree – Nursing

Prerequisites		
SDEV 0301 ¹	Learning Frameworks	0
BIOL 2401 ²	Anatomy & Physiology	4
BIOL 2420 ²	Microbiology for Non-Science Majors	4
PSYC 2301	General Psychology	3
HPRS 2300	Pharmacology for Health Professions	3
LEVEL I		
Semester I		
RNSG 1219 ³	Integrated Nursing Skills I	2
RNSG 1523	Intro to Professional Nursing for Integrated Programs	5
RNSG 1260 ³	Clinical I–Registered Nursing/Registered Nurse	2
PSYC 2314	Lifespan Growth & Development	3
BIOL 2402 ²	Anatomy & Physiology II	4
LEVEL II		
Semester II		
RNSG 2504	Integrated Care of the Patient with Common Health Needs	5
RNSG 2361	Clinical II–Registered Nursing/Registered Nurse	3
ENGL 1301	Composition I	3
LEVEL III		
Semester III		
RNSG 2514	Integrated Care of the Patient with Complex Health Needs	5
RNSG 2362	Clinical III–Registered Nursing/Registered Nurse	3
LEVEL IV		
Semester IV		
RNSG 2535 ⁺	Integrated Patient Care Management	5
RNSG 2363 ⁺	Clinical IV–Registered Nursing/Registered Nurse	3
Language, Philosophy & Culture/Creative Arts Elective from the Core Curriculum*		3

¹ Required for all first-time-in-college students. EDUC 1300 may be substituted for SDEV 0301.

² Students that take these courses at Victoria College will receive extra admission points toward their admission score.

³ Students who successfully complete RNSG 1219 with a C or better and RNSG 1260 with an S may apply for a Nurse Aide Certificate of Completion and are eligible to take the exam to become a Certified Nurse Aide.

⁺ Capstone course

* Students must choose a course from the VC Language, Philosophy & Culture/ Creative Arts Core Curriculum courses. Contact Advising & Counseling Services or program chair for specific course considerations.

- HPRS 2300 can be no more than three years old prior to acceptance. BIOL 2420, BIOL 2401, and BIOL 2402 can be no more than five years old. If BIOL 2401 and BIOL 2402 are over five years old, the applicant only will need to repeat BIOL 2402 by selection deadline. Psychology courses (PSYC 2301 & PSYC 2314) completed more than seven years prior must be repeated.

NOTE: Students that have completed BSN core courses will receive points toward their admission score.

NOTE: A minimum grade of C is required in all nursing and general education courses. All support courses must be taken during or before the semester designated on the degree plan.

Due to the continual change in clinical facilities, some alternate clinical learning experiences may be required in some semesters.

Nursing-Associate Degree (LVN-ADN Transition Program)

Victoria College offers the LVN-ADN Transition Program. Upon successful completion of RNSG 1327 and RNSG 1261, 12 hours equivalency credit for RNSG 1523, RNSG 1260, RNSG 1219 and RNSG 2361 will be granted. Upon successful completion of the program, the graduate is eligible to apply to take the National Council Licensure Examination for Registered Nurses (NCLEX-RN). Satisfactory achievement on the examination will qualify the graduate for licensure as a Registered Nurse.

The Associate Degree Nursing (ADN) program is fully approved by the Texas Board of Nursing and accredited by the Accreditation Commission for Education in Nursing (ACEN). Direct inquiries to 3390 Peachtree Road NE, Suite 1400, Atlanta, Georgia 30326, call (404) 975-5000.

Degree

Associate of Applied Science Degree – Nursing

Total credit hours: 60

Admission Requirements

Admission requirements for the Associate Degree Nursing (ADN) Program differ from general admission to Victoria College. Additional information may be found at www.VictoriaCollege.edu/ProfessionalNursing. The ADN Program is a selective admission program, which accepts a limited number of students each semester. All qualified applicants will be selected based on the program point system and selection process, which may be explained during the advising interview.

In order to be considered an eligible applicant, it is the responsibility of the applicant to ensure that all necessary documentation as stated below is in the ADN Office by March 1 for the summer transition program admission.

1. The student must meet the admission requirements for Victoria College as stated in the current College catalog. Contact the Admissions & Records Office.
2. High school graduate via official high school transcript or General Education Development (GED) equivalency is required for admission. Submit all official transcripts to the Admissions & Records Office.
3. Completed student ADN program application dated within the last year must have a Victoria College student application also (www.VictoriaCollege.edu/GettingStarted).
4. Graduation from an accredited VN program and current unencumbered Texas VN license. Students graduating from the Victoria College Vocational Nursing program and immediately transitioning to the ADN program must have a current unencumbered Texas VN license prior to admission into the transition program.
5. A complete Licensure Eligibility Question (LEQ) form must be submitted to the respective ADN Office and dated within the last year. It can take up to four months or longer for the Texas Board of Nursing (BON) to complete this process. Without resolution of all licensure eligibility issues, an applicant is not eligible for admission to the ADN Program. Once a clear Criminal Background Check (CBC) result is received from the Texas BON, it is the applicant's responsibility to submit original documentation to the respective ADN Office and also upload to the CastleBranch/ViewPoint website. A clear Texas BON CBC must be on file in the ADN Office by March 1 (faxed or scanned copies will not be accepted). The date on the document (postmark date on blue card or date on the letter) cannot be more than one year old.
6. A qualifying ATI TEAS test composite score of 68% or higher to be eligible for admission to the ADN Program. Additional points will be awarded for admission scores above a 68%. The applicant will be able to test three times in a 12-month period, with the most recent score being considered. The ATI TEAS score is good for two years from the testing date. Contact the VC Testing Center at (361) 582-2589 for further information regarding the ATI TEAS.
7. TSI (Texas Success Initiative) must be satisfied. Please contact Advising & Counseling Services and the Admissions & Records Office to validate TSI status.
8. A grade of C or better by March 1 for applicants in each of the following prerequisite courses:

BIOL 2401	BIOL 2420	HPRS 2300 (Pharmacology)	PSYC 2301
-----------	-----------	--------------------------	-----------

 Please note: Science courses (BIOL 2402 & BIOL 2420) completed more than five years ago must be repeated. HPRS 2300 (Pharmacology) will be within three years of completion. Psychology courses (PSYC 2301 & 2314) completed more than seven years prior must be repeated.
9. Official college transcripts from all colleges or universities attended must be on file in the Admissions & Records Office.
10. Overall GPA of 2.0 or above on all Victoria College hours attempted and GPA of 2.25 or higher in the ADN program of study. Any student whose cumulative GPA falls below 2.0 will not graduate.
11. ADN Program Advising interview is required no more than one year prior to program admission. Call (361) 572-6435 for more information.
12. Immunizations a) Measles, Mumps, and Rubella (MMR), b) Varicella (Chicken pox), c) Tetanus, Diphtheria, and Pertussis, (Tdap), and d) Hepatitis B series (takes 6 months to complete) are to be completed prior to the application deadline. Proof of serological immunity is acceptable. Prior to application deadline, the applicant will upload the required documentation into the CastleBranch/ViewPoint website and ensure acceptance by CastleBranch/ViewPoint.
13. Prior to enrollment, qualified applicants, who have been accepted into the ADN program must submit a) current American Heart Association Healthcare Provider CPR card or a current American Heart Association or American Red Cross Healthcare Provider CPR card, b) TB screening test, c) completed VC physical examination form, d) submit a 10-panel drug screen test, e) influenza vaccination, and f) COVID Vaccine or Exemption Status: At the discretion of the healthcare facility, proof of COVID vaccination or exemption may be required. All exemptions will be reviewed and handled on an individual basis by VC's Advising & Counseling Services office. The required documents will be uploaded by the applicant into the CastleBranch/ViewPoint website by the date indicated on the acceptance letter.
14. The last attempt of repeated course work (non-allied health courses) will count towards the allied health programs admission scores.
15. Students admitted to the nursing program who are unsuccessful with any course work will be allowed only one additional opportunity. After two unsuccessful attempts, students are not eligible to apply for readmission.
16. Students who are unsuccessful in the program and/or desire to reenter the program must repeat all concurrent nursing courses for that semester. This includes successful course work which the student received a grade of C or higher. Grade waivers will not be granted. Readmission must occur within two years of a prior admission.

Readmission and Transfer

Readmission and transfer students are considered on a space-available basis by readmission or transfer from outside the Victoria College system. However, students can be admitted twice. Readmission must occur within two years of a prior admission. Preference will be given as follows:

1. READMISSION OF PREVIOUSLY ENROLLED VICTORIA COLLEGE ADN STUDENTS

Students' course work and clinical performance will be evaluated by the ADN Program Chair. Students who wish to be considered for readmission must meet all current admission requirements as listed in the VC catalog. The student will need to meet with the ADN Program Chair to discuss all readmission criteria. The student will need to submit a letter to the program chair two months prior to the beginning of the semester that the student is considering to reenter. Any special circumstances involved in a students' withdrawal/dismissal from the program will be reviewed by the ADN Program Chair and Dean of Allied Health. Before registration, the Selection and Retention Committee will review the records and rank candidates seeking re-entry into Levels (semesters) I, II, III, IV based on the criteria in the Nursing Programs Handbook. The number of individuals selected for readmission is based on availability of seats per semester in the ADN Program. Students' coursework and clinical performance will be evaluated by the ADN program chair. Readmission students will be selected based on current GPA. Any special circumstances involved in a students' withdrawal/dismissal from the program will be reviewed by the ADN Program Chair and the Dean of Allied Health. Readmission must occur within two years of prior admission.

2. TRANSFER FROM OUTSIDE VICTORIA COLLEGE ADN SYSTEM

Transfer students are considered on a space available basis. Students who have successfully completed nursing courses at other accredited schools are evaluated on an individual basis by the ADN Program Chair to determine their entry level in the Victoria College ADN program. The transfer student must furnish a copy of each nursing course syllabus with course description to the ADN Program Chair so each course can be evaluated. Transfer students must meet the same admission and progression criteria as the Victoria College students. Completing at least 25% of the program of study, including the capstone course at Victoria College, is necessary to meet the requirements for graduation. It is the responsibility of the applicant to furnish all necessary documentation to the ADN office at least two months prior to the semester the student is seeking entry. Immunizations a) Measles, Mumps, and Rubella (MMR), b) Varicella (Chicken pox), c) Tetanus, Diphtheria, and Pertussis, (Tdap), and d) Hepatitis B series are to be completed prior to the application deadline. Proof of serological immunity is acceptable. Prior to acceptance, the applicant will upload documents into the CastleBranch website. Prior to enrollment, qualified applicants, who have been accepted into the ADN Program must submit a) current American Heart Association American or Red Cross Association Healthcare provider CPR card, b) completed VC physical examination form, c) submit a 10-panel drug screen test, and d) TB screening test, and e) COVID Vaccine or Exemption Status: The healthcare agencies may require students to provide verification of COVID vaccine or an exemption status. All exemptions will be reviewed on an individual basis by VC's Advising & Counseling Services office. These documents will be uploaded by the applicant into the CastleBranch website. Students are allowed two attempts for the duration of the program. After two unsuccessful attempts, students are not eligible to apply.

Nursing-Associate Degree (LVN-ADN Transition Program)

LVN Transition Curriculum

Prerequisites		
SDEV 0301 ¹	Learning Frameworks	0
BIOL 2401 ²	Anatomy & Physiology	4
BIOL 2420 ²	Microbiology for Non-Science Majors	4
PSYC 2301	General Psychology	3
HPRS 2300	Pharmacology for Health Professions	3

Semester I		
RNSG 1327	Transition from Vocational to Professional Nursing	3
RNSG 1261	Clinical – Transition – Nursing (RN Training)	2
PSYC 2314	Lifespan Growth & Development	3
BIOL 2402 ²	Anatomy & Physiology II	4

Upon successful completion of RNSG 1327 and RNSG 1261, 12 hours equivalency credit for RNSG 1523, RNSG 1260, RNSG 1219 and RNSG 2361 will be granted.

Semester II		
RNSG 2514	Integrated Care of the Patient with Healthcare Needs	5
RNSG 2362	Clinical III-Nursing (RN Training)	3
ENGL 1301	Composition I	3

Semester III		
RNSG 2535 ⁺	Integrated Patient Care Management	5
RNSG 2363 ⁺	Clinical IV – Registered Nursing/Registered Nurse	3
Language, Philosophy & Culture/Creative Arts Elective*		3

¹ Required for all first-time-in-college students. EDUC 1300 may be substituted for SDEV 0301.

² Students that take these courses at Victoria College will receive extra points towards their admission score.

* Capstone courses

* Student must choose a course from the VC Language, Philosophy & Culture/ Creative Arts Core Curriculum courses. Contact Advising & Counseling Services or program chair for specific course considerations.

- HPRS 2300 can be no more than three years old prior to acceptance. BIOL 2420, BIOL 2401, and BIOL 2402 can be no more than five years old. If BIOL 2401 and BIOL 2402 are over five years old, the applicant only will need to repeat BIOL 2402 by selection deadline. Psychology courses (PSYC 2301 & PSYC 2314) completed more than seven years prior must be repeated.

- It is strongly recommended that BIOL 2402 be taken prior to being accepted to the transition program.

NOTE: Students that have completed BSN core courses will receive points toward their admission score.

NOTE: A minimum grade of C is required in all nursing and general education courses. All support courses must be taken during or before the semester designated on the degree.

Due to the continual change in clinical facilities, some alternate clinical learning experiences may be required in some semesters.

Nursing-Vocational

Victoria College offers a 12-month certificate program in vocational nursing in Gonzales, Hallettsville, and Victoria. The program of study is designed to enable students to acquire knowledge, skills, and competencies related to enhancing the health and well-being of individuals. Vocational nursing graduates are prepared to function as members of the health care team under the supervision of registered nurses and physicians in varied health care settings. Completion of the program entitles the learner to apply to take the National Licensure Exam for Practical Nurses (NCLEX-PN). The Vocational Nursing Program is fully approved by the Texas Board of Nursing. Vocational Nursing Program graduates who have met all of the Associate Nursing Degree (ADN) admission requirements are eligible for summer admission into the ADN Transition Nursing Program following graduation.

Certificate

Certificate – Vocational Nursing

Total credit hours: 41

Admission Requirements

Admission requirements for the Vocational Nursing (VN) Program differ from general admission to Victoria College. Additional information may be found at VictoriaCollege.edu/VocationalNursing. The VN Program is a selective admission program, which accepts a limited number of students at each location. Applicants will be ranked based on the ATI TEAS Composite score.

In order to be considered eligible, all required documents relating to program admission must be in the respective VN Office by October 1 prior to spring admission.

The following are required for enrollment in the Vocational Nursing Program:

- The student must meet the admission requirements for Victoria College as stated in the current college catalog. Contact the Admissions & Records Office for more information.
- High School Graduate via official high school transcript or a General Education Development (GED) equivalency is required for admission. Submit all official transcripts to the Admissions & Records Office.
- Completion of the VN Program application for the year of enrollment and Victoria College student application (www.VictoriaCollege.edu/GettingStarted).
- A completed Licensure Eligibility Requirement (LER) form submitted to the respective VN Office. It can take up to four months or longer for the Texas Board of Nursing (BON) to complete this process. Without resolution of all licensure eligibility issues, an applicant is not eligible for admission to the Vocational Nursing Program. Once a clear Criminal Background Check (CBC) result is received from the Texas BON, it is the applicant's responsibility to submit original documentation to the respective VN Office and also upload to the CastleBranch/ViewPoint website. A clear Texas BON CBC must be on file in the VN Office by October 1 (faxed or scanned copies will not be accepted). The date on the BON document (blue card or letter) cannot be more than one year old.
- TSI (Texas Success Initiative) must be satisfied. Please contact Advising & Counseling Services and the Admissions & Records Office to validate TSI status.
- A qualifying ATI TEAS test composite score of 60% or higher. Applicants will be ranked based on the ATI TEAS Composite score. The applicant will be able to test three times in a twelve-month period with the most recent score being considered. The ATI TEAS score is good for two years from the testing date. Contact the Victoria College Testing Center at (361) 582-2589 for further information regarding the ATI TEAS. If a currently enrolled VN student is interested in entering into the Associate Degree Nursing (ADN) Transition program, an ATI TEAS score of 68% or higher is required.
- The following courses may be substituted for VNSG courses if completed with a C or better and taken prior to admission into the VN Program:

Substitute Course	VNSG Course
BIOL 1322 Nutrition & Diet Therapy	VNSG 1116 Nutrition
BIOL 2404 Introductory Anatomy & Physiology	VNSG 1420 Anatomy & Physiology for Allied Health
BIOL 2401 Anatomy & Physiology I and BIOL 2402 Anatomy & Physiology II	VNSG 1420 Anatomy & Physiology for Allied Health
PSYC 2301 General Psychology	VNSG 1136 Mental Health
PSYC 2314 Lifespan Growth & Development	VNSG 1133 Growth & Development

Please note: Science courses (BIOL 1322, BIOL 2404, & BIOL 2402) completed more than five years ago must be repeated. HPRS 2300 (Pharmacology) will be accepted within three years of completion. Psychology courses (PYSC 2301 & 2314) completed more than seven years prior must be repeated.

- Official college transcripts from **all** colleges or universities attended must be on file in the Admissions & Records Office by October 1.
- To be admitted into the nursing program, a student must have an overall GPA of 2.0 or above on all Victoria College courses. To maintain good standing in the program and be allowed to continue, a student must pass all required courses with a C or better. Any student whose cumulative GPA falls below a 2.0 will not graduate.
- Each applicant must schedule an appointment within two weeks of submitting the application to the VN Program. Schedule the appointment by calling your first choice campus VN Program's Administrative Assistant for guidance and direction on completing the application process. This appointment is mandatory to ensure all program requirements are met in a timely manner.
- Immunizations a) Measles, Mumps, and Rubella (MMR), b) Varicella (Chicken pox), c) Tetanus, Diphtheria, and Pertussis (Tdap), and d) Hepatitis B series (takes 6 months to complete) are to be completed prior to the application deadline. Proof of serological immunity is acceptable. Prior to application deadline, the applicant will upload the required documents into the CastleBranch/ViewPoint website and ensure acceptance by CastleBranch/ViewPoint.
- Prior to enrollment, qualified applicants who have been accepted into the VN Program must submit a) current American Heart Association Healthcare Provider CPR card or a current American Heart Association or American Red Cross Healthcare Provider CPR card, b) TB screening test, c) completed VC physical examination form, d) submit a 10-panel drug screen test, e) influenza vaccination for the current season, and f) COVID Vaccine or Exemption Status: At the discretion of the healthcare facility, proof of COVID vaccination or exemption may be required. All exemptions will be reviewed on an individual basis by VC's Advising & Counseling Services Office. The required documents will be uploaded by the applicant into theCastleBranch/ViewPoint website by the date indicated on the acceptance letter.
- Students who are unsuccessful in the program and/or desire to reenter the program must repeat all concurrent nursing courses for that semester. This includes successful coursework in which a student received a grade of "C" or higher. Readmission must occur within three years of a prior admission.
- Students interested in transferring into the VC ADN Program that are deemed eligible must make an appointment with the ADN Program Chair. All ADN prerequisite courses need to be completed by March 1 deadline.

PROGRAMS OF STUDY

Students can join the current VN class on a space-available basis by readmission, transfer within, transfer from ADN, or transfer from outside the Victoria College system. However, students can only be admitted into the VN Program twice. Preference will be given as follows:

1. READMISSION OF PREVIOUSLY ENROLLED VICTORIA COLLEGE VN STUDENTS

The number of individuals selected for readmission is based on availability of seats per semester in the VN Program. Students' coursework and clinical performance will be evaluated by the VN program chair. The student will need to meet with the VN Program Chair to discuss all readmission criteria. The student will need to submit a letter to the Program Chair two months prior to the beginning of the semester that the student is considering to reenter. Readmission students will be selected based on current GPA. Any special circumstances involved in a students' withdrawal/dismissal from the program will be reviewed by the VN Program Chair and the Dean of Allied Health. Students who desire to be readmitted into the program must repeat all unsuccessful courses from prior admission in the VN Program. Successful completion of some VNSG courses do not have to be repeated in which a C or higher was achieved. However, the following courses must be repeated in the respective semester of readmission: Semester I- VNSG 1260 Clinical and VNSG 1423 Basic Nursing Skills; Semester II-VNSG 1329 Medical Surgical Nursing I, VNSG 2260 Clinical, & VNSG 2331 Advanced Nursing Skills; Semester III- VNSG 1105 NCLEX-PN Review, VNSG 1432 Medical Surgical Nursing II, & VNSG 2461 Clinical. Readmission must occur within two years of a prior admission.

2. TRANSFER WITHIN VICTORIA COLLEGE SYSTEM

The student may seek transfer within the Victoria College Vocational Nursing system at the end of any semester by submitting a written request to the coordinator and VN Program Chair of each program involved two months prior to the end of the semester. Transfer students will be selected based on current GPA.

3. TRANSFER FROM OUTSIDE VICTORIA COLLEGE VOCATIONAL NURSING SYSTEM

Students who have successfully completed nursing courses at an approved school in good standing with the Texas Board of Nursing are evaluated on an individual basis by the VC Vocational Nursing Program Coordinator, Program Chair, and Dean of Allied Health to determine their entry level into the Victoria College Vocational Nursing Program. Transfer students must meet the admission, progression, and graduation requirements of Victoria College. The transfer student must furnish a copy of each nursing course syllabus with course description to the VN Program Chair so each course can be evaluated. Completing at least 25% of the program of study including the capstone course at Victoria College is necessary to meet the requirement for graduation. It is the responsibility of the applicant to furnish all necessary documents to the respective VN Office at least two months prior to the semester in which the student is seeking entry.

Students that have submitted a transfer request will be selected based on GPA.

Nursing-Vocational

Vocational Nursing Curriculum

Semester I Spring		
SDEV 0301 ¹	Learning Frameworks	0
VNSG 1116	Nutrition	1
VNSG 1133	Growth & Development	1
VNSG 1136	Mental Health	1
VNSG 1122	VN Concepts	1
VNSG 1423 ²	Basic Nursing Skills	4
VNSG 1420	Anatomy & Physiology for Allied Health	4
VNSG 1260 ²	Clinical-Licensed Practical/Licensed Vocational Nurse	2
Semester II Summer		
HPRS 2300	Pharmacology for Health Professions	3
VNSG 2331	Advanced Nursing Skills	3
VNSG 1329	Medical Surgical Nursing I	3
VNSG 2260	Clinical-Licensed Practical/Licensed Vocational Nurse	2
Semester III Fall		
VNSG 1234	Pediatric Nursing	2
VNSG 1432	Medical Surgical Nursing II	4
VNSG 1230	Maternal-Neonatal Nursing	2
VNSG 1238	Mental Illness	2
VNSG 1105	NCLEX-PN Review	1
VNSG 1119	Leadership and Professional Development	1
VNSG 2461 ⁺	Clinical-Licensed Practical/Licensed Vocational Nurse	4

1 Required for all first-time-in-college students. EDUC 1300 may be substituted for SDEV 0301.

2 Students who successfully complete VNSG 1423 with a C or better and VNSG 1260 with a S may apply for a Nurse Aide Certificate of Completion and are eligible to take the exam to become a Certified Nurse's Aide.

+ Capstone course

For the student who is a Certified Nurse Aide, completion of Semester II of the program allows the student to apply for the Texas Medication Aide Certification Exam.

If Biology courses taken prior to acceptance, note that BIOL 1322, BIOL 2401, and BIOL 2402 expire after five years.

HPRS 2300 can be no more than three years prior to acceptance.

Psychology courses (PSYC 2301 & 2314) completed more than seven years prior must be repeated.

Note: Students interested in direct admission into the ADN Transition Program are strongly recommended to complete BIOL 2401, BIOL 2402, and BIOL 2420 prior to VN admission. VNSG 1420 is not accepted by the ADN Program.

NOTE: A minimum grade of C is required in all nursing and general education courses. All support courses must be taken during or before the semester designated on the degree.

To assure quality clinical learning experiences for all students, some evening and weekend clinical experiences may be required. Due to the continual change in clinical facilities, some alternate clinical learning experiences may be required in some semesters.

VN students may be required to travel to other learning sites.

Physical Therapist Assistant Program

Victoria College offers a two-year program in physical therapist assisting, which leads to an Associate of Applied Science degree. The program of study is designed to enable students to acquire knowledge, skills, and competencies related to restoring function and well-being of individuals. Physical therapist assistants are prepared to function as members of the health care team. Upon successful completion of the program, the graduate will be eligible to take the National Physical Therapist Assistant licensing examination.

The Victoria College's Physical Therapist Assistant Program is accredited by the Commission on Accreditation in Physical Therapy Education of the American Physical Therapy Association (3030 Potomac Ave. Suite 100 Alexandria, VA 22305-3085, accreditation@apta.org; (703) 684-2782 or (800) 999-2782.

Degree

Associate of Applied Science Degree – Physical Therapist Assistant

Total credit hours: 66

Students completing the entire curriculum are eligible to apply for an Associate of Applied Science Degree in Physical Therapist Assistant from Victoria College and will be eligible to take the National Physical Therapist Assistant licensing examination.

Admission Requirements

Admission requirements for the Physical Therapist Assistant (PTA) Program differ from general admission to Victoria College. Additional information may be found at www.VictoriaCollege.edu/PhysicalTherapistAssistant. The PTA Program is a selective admission program with a limited number of available student slots.

1. The student must meet the admission requirements and complete the general admission application for Victoria College as stated in the current College catalog.
2. Complete the PTA Program application by May 15 for summer admission.
3. Complete 30 hours of observation, volunteer work, or work experience in the field of physical therapy. These hours must be a combination of at least two different settings in physical therapy (i.e. inpatient, outpatient, rehabilitation clinic, skilled nursing facility, home health, or pediatric), and one setting must have a minimum of eight hours. These hours must be documented on the form provided in the application (application forms can be obtained at www.VictoriaCollege.edu/PhysicalTherapistAssistant or from the PTA Program Office).
4. Overall GPA of 2.0 or better on all college hours attempted. Submission of all official college transcripts from any college attended other than Victoria College to the Admissions & Records Office.
5. TSI (Texas Success Initiative) must be satisfied. Contact Advising & Counseling Services for further explanation, if necessary.
6. There are no prerequisite courses for the PTA Program. HOWEVER, selective admission into the Program is based on a point system. The student is given points based on completion of any of the general academic courses listed in the PTA Degree Plan (i.e., BIOL 2404, ENGL 1301, etc.); and the amount of points awarded is also based on the grade made in each course (i.e., an A in BIOL 2404 = 16 points out of a possible 16 points, a C in BIOL 2404 = 8 points out of a possible 16). Completion of the general education courses enhances the student's selection to the Program. To be awarded points, the course(s) MUST BE COMPLETED, with a grade given, by May 15. General education courses not completed before Program entry must be completed BEFORE entering the final semester in the PTA Program (Spring II semester). The Anatomy/Physiology course(s) must be taken within five years of application date.
Please note: The last attempt of repeated course work (non- PTA courses) will count towards the allied health programs admission scores.
7. Official college transcripts must be turned in to the Admission & Records Office from all colleges and universities attended. Students should make sure they are the most current transcripts. All general education courses already taken in the program of study must be verified with official transcripts indicating the course has been completed with a grade of C or better.
8. Two recommendation letters (forms enclosed in application forms packet): One from an academic instructor and one from an employer. If a student has not had an employer, they may submit both recommendation letters from instructors. (See PTA forms online at www.VictoriaCollege.edu/PhysicalTherapistAssistant.)
9. Scores will be tabulated and ranked in order. Further information regarding the scoring process may be obtained from the Program Director.
10. A criminal background check and drug screen will be required after acceptance, prior to entrance to the program. The cost is at the applicant's expense and is approximately \$70. Total cost of View Point is \$90 which includes \$70 required for background test and drug screen. An applicant with an unsatisfactory criminal background check must complete the Criminal History Evaluation Form on the Physical Therapy Board Website at <https://www.ptot.texas.gov/page/home>, as mandated by the Legislature to determine if they will be eligible to take the licensing examination after graduation. It will cost the individual with the criminal history \$50 for this review. It is highly recommended this review of a negative background check be completed before entering the program, but MUST be completed before starting the first clinical education experience after beginning the program. Students who do not have clear background checks or negative drug tests may not be able to meet all course objectives, which will result in unsuccessful completion of the program.
11. Qualified applicants who have been accepted into the PTA Program must submit a current American Red Cross CPR for Professional Rescuers or American Heart Association-BLS provider, a completed physical examination form, and a current immunization record showing they have met all the required immunizations (see PTA Application Information Guide at www.VictoriaCollege.edu/PhysicalTherapistAssistant). A COVID Vaccine or Exemption Status: At the discretion of the healthcare facility, proof of COVID vaccination or exemption may be required. All exemptions will be reviewed and handled on an individual basis by VC's Advising & Counseling Services office. The required documents will be uploaded by the applicant into the ViewPoint website by the date indicated on the acceptance letter. This documentation MUST be submitted prior to the first day of the first class in the PTA Program.

Physical Therapist Assistant

Associate of Applied Science Degree

Summer Session I		
SDEV 0301 ¹	Learning Frameworks	0
PTHA 1301	Profession of Physical Therapy	3
BIOL 2404 ² or BIOL 2401 and BIOL 2402	Introductory to Anatomy & Physiology	4
	Anatomy & Physiology I	
	Anatomy & Physiology II	
Summer Session II		
PTHA 1321	Pathophysiology for the PTA	3
ENGL 1301	Composition I	3
Fall I		
PTHA 1305	Basic Patient Care Skills	3
PTHA 1413	Functional Anatomy	4
PTHA 2201	Essentials of Data Collection	2
ENGL 2311	Technical Writing	3
SPCH 1311 or SPCH 1318	Introduction to Speech Communication	3
	Interpersonal Communication	
Spring I		
PTHA 1191	Special Topics in Physical Therapy Assistant	1
PTHA 1431	Physical Agents	4
PTHA 2409	Therapeutic Exercise	4
PSYC 2301	General Psychology	3
MATH 1332 or MATH 1314 ³	Contemporary Mathematics	3
	College Algebra	
Summer Session I		
PTHA 1266	Practicum I – Physical Therapist Assistant	2
Fall II		
PTHA 2435	Rehabilitation Techniques	4
PTHA 2531	Management of Neurological Disorders	5
PSYC 2314	Lifespan Growth and Development	3
Language, Philosophy & Culture/Creative Arts Elective from the Core Curriculum		3
Spring II		
PTHA 2339	Professional Issues	3
PTHA 2366	Practicum II – Physical Therapist Assistant	3

¹ Required for all first-time-in-college students. EDUC 1300 may be substituted for SDEV 0301.

² BIOL 2404 can be replaced by the completion of both BIOL 2401 and 2402.

³ Any higher-level mathematics elective from core curriculum is accepted

Process Technology

The Process Technology Program at Victoria College prepares students for a career as a process technician or operator. Process technicians are trained to operate, analyze, and troubleshoot industrial processes to produce products safely and efficiently. They gather information using instrumentation that monitors process conditions such as pressure, temperature, level, and flow rates. They operate various types of mechanical equipment, such as pumps, valves, and compressors, and apply quality principles to produce products that meet customer specifications.

Process technicians may work both indoors and outdoors alongside chemical engineers, maintenance personnel, and other professionals. They will be expected to use their knowledge of computers, math, physics, and chemistry to monitor and troubleshoot plant operations. Skills that are taught that are necessary to succeed as a process technician include effective communication, reading and writing clearly and concisely, how to give oral presentations, and techniques to exercise effective listening.

Upon successful completion of the Process Technology Program, students will be prepared to work as a process technician in any of the various local industries, including petrochemical plants and refineries, oil and gas production, and power generation.

Students are encouraged to concentrate on obtaining a certificate during the first year (fall/spring semesters) to ensure a solid technical foundation should an employment opportunity become available that will accept a certificate instead of an AAS. To complete a certificate in two semesters, students MUST take PTAC 1302, 1410, and 1432 in the Fall and PTAC 2438, 2420, and 2446 in the Spring.

Program curriculum, course identifications, titles, and descriptions are subject to change and approval of the Texas Higher Education Coordinating Board. For current curriculum or more information visit www.VictoriaCollege.edu/ProcessTechnology, call (361) 573-3291 ext. 3289, or email Lawrence.Wick@VictoriaCollege.edu.

Degree

Associate of Applied Science Degree – Process Technology

Total credit hours: 60

Students who successfully complete the program may apply for an Associate of Applied Science degree. It is highly recommended that motivated students earn their certificate the first year and then return to finish the AAS. To complete the certificate in two semesters, students MUST take PTAC 1302, 1410, and 1432 in the Fall and PTAC 2438, 2420, and 2446 in the Spring.

Certificate

Process Technology Certificate

Total credit hours: 23

Students who successfully complete the required courses may apply for a Certificate in Process Technology.

The required courses for a certificate are PTAC 1302, 1410, and 1432 that must be taken in the Fall and PTAC 2438, 2420, and 2446 which are taken in the Spring.

Block Schedule is available for students pursuing the Process Technology Certificate. Block Scheduled programs allow for predictability of course scheduling from semester to semester-allowing students to arrange work/family schedules.

Process Technology

Associate of Applied Science Degree

Freshman Year		
Summer Session		
SDEV 0301 ¹	Learning Frameworks	0

Fall Semester		
PTAC 1302	Introduction to Process Technology	3
PTAC 1432	Process Instrumentation I	4
PTAC 1410	Process Technology I – Equipment	4
CHEM 1406	Introductory Chemistry I	4

Spring Semester		
CETT 1302	Electricity Principles	3
PTAC 1308	Safety, Health, and Environment I	3
PTAC 2438	Process Technology III – Operations	4
MATH 1332 or MATH 1314	Contemporary Mathematics College Algebra	3

Sophomore Year		
Fall Semester		
PTAC 2348	Safety, Health, and Environment II	3
PTAC 2314	Principles of Quality	3
PTAC 1354 or PTAC 2386*	Industrial Processes Internship-Process Technology	3
PHYS 1310 ²	Elementary Physics	3
Language, Philosophy & Culture/Creative Arts Elective from Core Curriculum		3

Spring Semester		
PTAC 2420*	Process Technology II – Systems	4
PTAC 2446	Process Troubleshooting	4
ECON 2301 ³	Principles of Macroeconomics	3
ENGL 2311 ⁴	Technical & Business Writing	3
BMGT 1307	Team Building	3

Process Technology
Certificate

X
X
X

X

X
X

X
X

¹ Required for all first-time-in-college students. EDUC 1300 may be substituted for SDEV 0301.

² Any higher-level PHYS will be accepted

³ American History, Government/Political Science, or Social and Behavioral Sciences Elective from Core Curriculum

⁴ Will accept ENGL 1301

* Capstone course

*PTAC 2386 can be taken only once. Enrollment is contingent upon instructor approval and commitment of employer for an internship position. PTAC 2386 can be substituted for PTAC 1354 with approval from the department chair.

All courses with the exception of PTAC 1302 will be offered only during the semester listed.

Respiratory Care Program

Victoria College offers a two-year associate degree program in respiratory care. Upon successful completion of the AAS degree program, the graduate will be eligible to take a series of national board exams to become a registered respiratory therapist (RRT).

Respiratory therapists are the health specialists who evaluate, treat, and care for patients with breathing disorders. They work under the direction of a physician and assist in the diagnosis, treatment, and management of patients with pulmonary disorders.

The program is designed with great attention to the professional standards and requirements outlined by our regulating agencies. Students will be engaged in didactic, laboratory, and clinical instruction each week. The program faculty is committed to student success and professional integrity. The program has multiple clinical affiliates where students will receive clinical training.

The program is designed to offer students a comprehensive learning experience with didactic, laboratory, and clinical instruction and also is committed to the growth of the student as a professional. To that end, the program has a student service organization, SCOPE, in which students are required to hold membership during their enrollment in the program. During the final semester of the program, students can become eligible for induction in the Lambda Beta Society, which is the profession's national honor society. Students are required to become members of the state society (TSRC) and the national association (AARC) while in the program as a part of their integration into the profession.

Victoria College's Respiratory Care Program is accredited by the Commission on Accreditation for Respiratory Care, 264 Precision Blvd Telford, TN 37690 USA; (817) 283-2835 (www.coarc.com). The program has received a Certificate of Accreditation valid until 11/30/2027.

For more information, visit www.VictoriaCollege.edu/RespiratoryCare or call (361) 572-6460.

Degree

Associate of Applied Science Degree – Respiratory Care

Total credit hours: 66

Students who successfully complete the program may apply for an Associate of Applied Science degree.

Application Requirements

Students who apply to the Respiratory Care Program for the fall semester **MUST** have their first hepatitis B injection no later than January 15. Students who have not completed the hepatitis B series by August 1 will not be able to enroll in the Respiratory Care Program.

It should be noted that as a respiratory therapist you must be able to walk at a fast pace, climb stairs rapidly, have good peripheral vision, and lift objects weighing over 25 pounds. Applicants must meet all technical standards.

Admission Requirements

Applicants must meet special entrance requirements and complete a department application.

For more information about the program and course schedule assistance, contact the Program Chair. Additional information may be found at www.VictoriaCollege.edu/RespiratoryCare.

- Students must meet the admission requirements for Victoria College as stated in the current college catalog. Contact the Admissions & Records Office. Applicants must have a high school diploma or GED.
- Complete general admission application as required by the Admissions & Records Office.
- Complete the Respiratory Care Program application by May 1 for fall admission. Three letters of recommendation must be included with the application.
- An interview with the Program Chair is required. Applicants will be selected for the program based on compliance with all requirements, interview performance, and reference letters and/or conversations held during the reference inquiry.
- Submit a one-page typed/written essay as to why the applicant should be considered for acceptance into the Respiratory Care Program.
- It is the responsibility of the applicant to furnish all necessary documentation to the Respiratory Care Department (including the interview by May 1 for fall admission). Late applications are considered if spaces are available.
- TSI (Texas Success Initiative) must be satisfied. Contact Advising & Counseling Services for further explanation if necessary.
- Overall GPA of 2.25 or above on all college hours attempted. Students with less than a 2.25 GPA will be evaluated on an individual basis.
- The following courses **must** be completed with a grade of C or better prior to enrolling in the program:
 - ENGL 2311 Technical & Business Writing
 - PSYC 2301 General Psychology or SOCI 1301 Introduction to Sociology
 - BIOL 2404 Intro to Anatomy & Physiology or BIOL 2401 and BIOL 2402
 - Mathematics – Select one course from the Victoria College Core Curriculum
 - Creative Arts – Select one course from the Victoria College Core Curriculum
- A minimum grade of C is required in all respiratory care and general education courses.
- Official high school and college transcripts must be on file in the Admissions & Records Office and Respiratory Care Department.
- Transfer students will be accepted on an individual basis.
- Previous respiratory care students who received a certificate from Victoria College and are currently registered therapists may receive equivalency credit toward an AAS degree. See Program Chair for specific procedure.
- Science courses taken more than five years ago will be evaluated on an individual basis and may have to be repeated.
- Clear criminal background and drug testing are required prior to admission.
- Prior to enrollment, qualified applicants who have been accepted into the Respiratory Care Program must submit a current CPR Health Care Provider card, a completed physical examination form, and must meet the program immunization requirements. A COVID Vaccine or Exemption Status: At the discretion of the healthcare facility, proof of COVID vaccination or exemption may be required. All exemptions will be reviewed and handled on an individual basis by VC's Advising & Counseling Services office. The required documents will be uploaded by the applicant into the CastleBranch/ViewPoint website by the date indicated on the acceptance letter.

Respiratory Care

Associate of Applied Science Degree

Prerequisites		
SDEV 0301 ¹	Learning Frameworks	0
ENGL 2311	Technical & Business Writing	3
PSYC 2301 or SOC1 1301	General Psychology	3
	Introduction to Sociology	
BIOL 2404 or BIOL 2401 and BIOL 2402	Introductory Anatomy & Physiology	4
	Anatomy & Physiology I	
	Anatomy & Physiology II	
Mathematics – Select 1 course from Victoria College Core Curriculum		3
Language, Philosophy & Culture/Creative Arts Elective from the Core Curriculum		3

¹ Required for all first-time-in-college students. EDUC 1300 may be substituted for SDEV 0301.

First Year		
Fall Semester		
RSPT 1113	Respiratory Care Pharmacology	1
RSPT 1240	Advanced Cardiopulmonary Anatomy Physiology	2
RSPT 1410	Respiratory Care Procedures I	4
RSPT 1360	Clinical–Respiratory Therapy I	3
Spring Semester		
RSPT 1411	Respiratory Care Procedures II	4
RSPT 1361	Clinical–Respiratory Therapy II	3
RSPT 2243	Resource in Respiratory Care	2
RSPT 2310	Cardiopulmonary Disease	3
Summer Session		
RSPT 2258	Respiratory Care Patient Assessment	2
RSPT 1141	Respiratory Home Care/Rehabilitation	1
RSPT 1137	Basic Dysrhythmia Interpretation	1
RSPT 1163	Clinical–Respiratory Therapy III	1
RSPT 2135	Pediatric Advanced Life Support	1
RSPT 2139	Advanced Cardiac Life Support	1
Second Year		
Fall Semester		
RSPT 2414	Mechanical Ventilation	4
RSPT 2453	Neonatal/Pediatric Cardiopulmonary Care	4
RSPT 2360	Clinical–Respiratory Therapy IV	3
Spring Semester		
RSPT 2133	Respiratory Care Case Management	1
RSPT 2147	Specialties in Respiratory Care	1
*RSPT 2231	Simulations in Respiratory Care	2
RSPT 2361	Clinical-Respiratory Therapy V	3
RSPT 2325	Cardiopulmonary Diagnostics	3

* Capstone course

NOTE: Some evening and weekend clinical learning experiences may be required in some semesters.

Welding

Welding is the most common way of permanently joining metal parts. In this process, heat is applied to metal pieces, melting and fusing them to form a permanent bond. Because of its strength, welding is used in shipbuilding, automobile manufacturing and repair, aerospace applications, and thousands of other manufacturing activities. Welding also is used to join beams when constructing buildings, bridges, and other structures, and to join pipes in pipelines, power plants, and refineries. Welders use many types of welding equipment set up in a variety of positions, such as flat, vertical, horizontal, and overhead.

In the VC Welding Program, courses focus on specific welding processes including Shielded Metal Arc Welding, Gas Tungsten Arc Welding, Flux-Cored Arc Welding, and Gas Metal Arc Welding. Students' welds are tested for quality assurance in accordance with national welding codes. Welding is performed on carbon steel, stainless steel, and aluminum plate and pipe. Additional skills include blueprint reading, as well as product design, fabrication, and layout. Graduates have the option to apply for national welding certification. Upon completion of the program, students will possess the knowledge and technical skills necessary to pursue a welding career in a variety of jobs.

Program curriculum, course identifications, titles, and descriptions are subject to change and approval of the Texas Higher Education Coordinating Board. For current curriculum or more information, visit www.VictoriaCollege.edu/Welding, contact the Welding Program office at (361) 572-6471, or email Wade.Vrana@VictoriaCollege.edu.

Certificates

Basic Welding Certificate

Total credit hours: 34

Students who successfully complete the basic certificate requirements may apply for a Certificate of Completion in Basic Welding. CNBT 1091 is required only for students pursuing NCCER Certification.

Advanced Welding Certificate

Total credit hours: 42

Students who successfully complete the advanced certificate courses and basic certificate requirements may apply for a Certificate of Completion in Advanced Welding. CNBT 1091 is required only for students pursuing NCCER Certification.

Welding Occupational Skills Award

Total credit hours: 12

Students who successfully complete the Occupational Skills Award requirements may apply for a Certificate of Completion. CBNT 1091 is required only for students pursuing NCCER Certification.

Block Schedule is available for students pursuing each certificate.

PROGRAMS OF STUDY

Welding

Summer Session			Basic Welding Certificate	Advanced Welding Certificate	Welding Occupational Skills Award
SDEV 0301 ¹	Learning Frameworks	0			
CNBT 1091 ^{2 3}	NCCER Core Skills for Construction Trades	0	X	X	X
Fall Semester					
WLDG 1421 ^{2 3}	Welding Fundamentals	4	X	X	X
WLDG 1417	Intro to Layout and Fabrication	4	X	X	
WLDG 2443 ^{2 3}	Adv Shielded Metal Arc Welding	4	X	X	X
Spring Semester					
WLDG 2435	Advanced Layout and Fabrication	4	X	X	
WLDG 2406 ^{+ 3}	Intermediate Pipe Welding	4	X	X	X
WLDG 1434 ³	Intro to Gas Tungsten Arc Welding	4	X	X	
Fall Semester					
MCHN 1343	Machine Shop Mathematics	3	X	X	
DFTG 1325 ³	Blueprint Reading and Sketching	3	X	X	
WLDG 1430 ³	Intro to Gas Metal Arc Welding	4	X	X	
Spring Semester					
WLDG 2451 ^{+ 3}	Advanced Gas Tungsten Arc Welding	4		X	
WLDG 2452 ³	Advanced Flux Cored Arc Welding	4		X	

¹ Required for all first-time-in-college students. EDUC 1300 may be substituted for SDEV 0301.

² Completion of these courses will enable students to apply for NCCER Level 1 Welding Certificate.

³ Completion of these courses will enable students to apply for NCCER Level 1-3 Welding Certification. Additional lab and classroom testing is required. Testing will be conducted during hours outside of regular class time. Additional fees apply.

+ Capstone course

(This page left blank intentionally)

Workforce & Continuing Education

Workforce & Continuing Education (Noncredit)

Victoria College Workforce & Continuing Education Mission Statement

Continuing education that effectively fulfills business, industry, and individual needs for quick response to preparatory, supplemental, or professional development training.

Industrial Trades Courses

Automotive Service Excellence (ASE) Certification Testing
 Carpentry
 Construction Site Safety Technician (CCST)
 Electrical
 Fiber Optics Technician
 Fiber Optics Specialist
 Heating, Ventilation & Air Conditioning (HVAC)
 Millwright
 NCCER Core Curriculum: Introductory Craft Skills
 Pipefitting
 Plumbing
 Power Line Worker
 Scaffold Worker
 Truck Driving
 Warehouse Vehicle Operation
 Welding

Certifications

Industrial Electrical Certified Plus Performance Verifications
 Millwright Certified Plus Performance Verifications
 Scaffold Certified Plus Performance Verifications

Completion of these courses, in addition to the knowledge verification, allows the student to become NCCER Certified Plus, which is the highest NCCER credential available.

Professional Continuing Education

EPA Technician Certification
 Law Enforcement – Basic Peace Officer
 Real Estate

Courses

Business and Customer Service
 Computer Applications
 Language Skills
 Legal Support Personnel
 Motorcycle Safety
 Personal Enrichment
 Real Estate

Allied Health Continuing Education (Noncredit)

Programs

Electrocardiogram (EKG) Technician
 Medical Assisting
 Medical Coding
 Medication Aide
 Mental Health Technician
 Nursing Assistant (Aide)
 Pharmacy Technician
 Phlebotomy
 Veterinary Assistant

Professional Continuing Education

Emergency Medical Services
 Medication Aide Update

NOTE: All programs of study are subject to change. Please refer to the Victoria College website at VictoriaCollege.edu for current programs of study.

Workforce & Continuing Education (Noncredit)

Academy of Lifelong Learning

The Academy of Lifelong Learning (ALL) is a member-driven organization for active adults. ALL offers members with common interests the opportunity to participate in lectures, discussions, social outings, and a variety of different classes. Members have access to a variety of classes and activities each year. The Academy of Lifelong Learning is available in both Victoria and Gonzales.

Victoria, TX: Academy of Lifelong Learning

Membership is \$80 per year (\$55 for those joining after January 1).

For more information:

www.VictoriaCollege.edu/AcademyOfLifelongLearning
(361) 582-2520
WCE@VictoriaCollege.edu

Gonzales, TX: Academy of Lifelong Learning

Membership is \$50 per year

www.VictoriaCollege.edu/AcademyOfLifelongLearning
(830) 857-6254
Melissa.Robinson@VictoriaCollege.edu

Computer Applications

Courses vary from the most basic computer literacy courses to advanced courses in web design and programming.

Short Courses –

Minimum time. Maximum learning.

Excel, Internet & Email, Outlook, PowerPoint, QuickBooks, Windows, Word

Online Courses –

A world of choices.

Your schedule. Your location.

Education to Go – www.ed2go.com/victoria

For more information:

www.VictoriaCollege.edu/WCE
(361) 582-2528
WCE@VictoriaCollege.edu

Employee Training

Victoria College is your partner for innovative learning solutions for you and your business. We can provide the highest quality, customized training to meet the needs of the changing workforce. Our customized training services are designed to respond to your organization's development needs quickly and affordably. We have courses tailored to the needs of your employees at all levels and from all backgrounds.

For more information:

www.VictoriaCollege.edu/WCE
(361) 582-2590
Nicole.Uresti@VictoriaCollege.edu

Environmental Protection Agency (EPA) Technician Certification

Enrolled participants will receive instruction in compliance with the Federal Clean Air Act, Section 608, and will take the EPA Technician Certification Exam. Certification cards will be issued from ESCO Group to individuals who pass the exam. Exam fees are included in tuition. HVAC 1 and/or prior HVAC experience recommended. Workbook is included in tuition and will be provided upon registration.

For more information:

www.VictoriaCollege.edu/WCE
(361) 582-2528
WCE@VictoriaCollege.edu

Industrial Training

Victoria College's Workforce & Continuing Education Department, in partnership with the Industrial Merit Shop Education Foundation (IMSEF), offers nationally accredited craft training. Training consists of multiple levels for each craft area. These courses are taught in progressive levels using the nationally recognized National Center for Construction Education and Research (NCCER) curriculum. NCCER's industry-recognized credentials provide students and craft professionals with national portability of skills. Victoria College partners with IMSEF to provide NCCER certification to all students who successfully complete our Carpentry, and Construction Site Safety Technician (CSST), Electrical, HVAC, Millwright, NCCER Core Curriculum: Introductory Craft Skills, Pipefitting, Plumbing, Power Line Worker, Scaffolding, or Welding training.

Unless otherwise noted, tuition includes all course materials, including textbooks.

Automotive Service Excellence (ASE) Certification Testing

Are you certified? ASE Certification verifies student's technical knowledge in the automotive service industry.

Carpentry Level 1*

Prerequisite: NCCER Core Curriculum: Introductory Craft Skills

This course provides an introduction to the carpentry trade. Topics include:

- Orientation to the Trade Building Materials, Fasteners, and Adhesives
- Hand and Power Tools
- Introduction to Construction Drawings, Specification, and Layout
- Floor Systems
- Wall Systems
- Ceiling Joist and Roof framing
- Basic Stair Layout

Carpentry Level 2*

Prerequisite: Carpentry Level 1

This intermediate course provides study in the installation of exterior and interior finish systems and components including the placement and installation of cornice, windows, doors, siding, flashing, trim, floor, wall, and ceiling finishes. Emphasis on safe work practices and the use, and maintenance of tools and equipment.

Construction Site Safety Technician (CSST)*

This course is designed for industry safety professionals, company safety officers, current site safety coordinators, or foremen seeking to improve safety knowledge and skills.

Topics include:

- Introduction to Safety
- Confined spaces and excavations
- Work-zone safety
- Electrical safety
- Introduction to safety technology
- Positive safety communication
- Hazard recognition, environmental awareness, and occupational health
- Job safety analysis and pre-task planning
- Safety data tracking and trending
- Site-specific safety plans
- Safety orientation and safety meetings
- Permits and policies
- Incident investigations, policies, and analysis
- OSHA inspections and record-keeping

NCCER Core Curriculum: Introductory Craft Skills*

Prerequisite: None

Core Curriculum: Introductory Craft Skills is common to all NCCER Training Programs and is required for NCCER Certification for all Level 1 courses. No prior experience necessary. Students will not receive NCCER certifications for any industrial course unless this course has been successfully completed. Topics include:

- Introduction to basic safety
- Communication and basic employability skills
- Blue prints and construction math
- Hand and power tools

Electrical Level 1*

Prerequisite: NCCER Core Curriculum: Introductory Craft Skills

This course provides an introduction to the electrical trade. Topics include:

- Introduction to electrical circuits, theory, and safety
- Introduction to the National Electrical Code®
- Conductors and cable, device boxes, hand bending
- Residential electrical services

Electrical Level 2*

Prerequisite: Electrical Level 1

A study in alternating current, motors, theory, and application. Topics include:

- Circuit breakers and fuses
- Conductor installations, terminations, and splices
- Conduit bending
- Grounding and bonding
- Pull and junction boxes

Electrical Level 3*

Prerequisite: Electrical Level 2

This course is a study of the principles of operation of single- and three-phase motors and transformers. Topics include:

- Ground fault
- Protective devices
- Short circuit and size overcurrent
- Transformer banking
- Wye and Delta connections

Electrical Level 4*

Prerequisite: Electrical Level 3

This course provides an advanced study in load calculations – feeders and services, health care facilities, standby, and emergency systems. Topics include:

- Advanced controls and fire alarm systems
- HVAC controls
- Heat tracing and freeze protection
- Motor operation and maintenance
- Medium-voltage terminations/splices
- Specialty transformers

Fiber Optics Technician*

Prerequisite: Basic working knowledge of computers, the ability to see and identify small items, and the ability to speak the English language.

This introductory fiber optics technician course, which is offered in partnership with BDI DataLynk, is designed for anyone interested in becoming a Certified Fiber Optic Technician. The course combines theory and 85% hands-on activities to prepare the student to take the CFOT (Certified Fiber Optic Technician) exam that is sanctioned by the FOA (Fiber Optics Association).

Fiber Optics Specialist*

Prerequisite: Successful completion of Fiber Optic Technician; the ability to see, manipulate, and hold small tools and test equipment; and ability to read and speak the English language.

This comprehensive fiber optics course, which is offered in partnership with BDI DataLynk, explains the variety of testing standards, equipment, and technological approaches used in fiber network testing and splicing and how to choose among them. This course combines theory and 85% hands-on activities to prepare the student to take two certification exams, including the CFOS/T (Certified Fiber Optics Testing & Maintenance Specialist), and CFOS/S (Certified Fiber Optic Specialist in Splicing) tests that are sanctioned by the FOA (Fiber Optics Association).

Heating, Ventilation & Air Conditioning (HVAC) Level 1*

Prerequisite: NCCER Core Curriculum: Introductory Craft Skills

This introductory course covers heating, ventilation, and air conditioning (HVAC) principles. Topics include:

- Introduction to cooling, heating, and basic electricity
- Air distributing systems
- Copper and plastic piping practices, soldering and brazing
- Trade mathematics
- Ferrous metal piping practices

Heating, Ventilation & Air Conditioning (HVAC) Level 2*

Prerequisite: HVAC Level 1

This is an intermediate HVAC course. Topics include:

- Basic installation and maintenance practices, basic electronics
- Introduction troubleshooting control circuit, gas heating and cooling
- Commercial airside systems chimneys, vents, and flues
- Air quality equipment
- Leak detection, evacuation, recovery, and charging
- Fiberglass and flexible duct systems

Heating, Ventilation & Air Conditioning (HVAC) Level 3*

Prerequisite: HVAC Level 2

This is an intermediate HVAC course and is a continuation of HVAC Level 2. Topics include:

- A study of refrigerants and oils
- Compressors and metering devices
- Retail refrigeration systems and commercial hydronic systems
- Planned maintenance
- Troubleshooting electronic controls, oil heating, heating pumps, and accessories

Heating, Ventilation & Air Conditioning (HVAC) Level 4*

Prerequisite: HVAC Level 3

This course is an advanced study of HVAC. Topics include:

- Construction drawings and specifications
- System balancing
- Energy conservation equipment and building management systems
- System startup and shutdown
- Commercial and industrial refrigeration systems
- Alternative heating and cooling systems

EPA Technician Certification

Prerequisite: HVAC Level 1 or prior HVAC experience

This course will provide the student with instruction in compliance with the Federal Clean Air Act, Section 608 and is designed to permit the certification of technicians as required by this act. Topics include:

- Type 1 Certification - working on small appliances
- Type 2 Certification - working on medium, high, and very-high pressure appliances
- Type 3 Certification - working on low pressure appliances

Industrial Electrician Certified Plus Performance Verification

NCCER's Certified Plus certification requires both knowledge and performance verification. Participants will be tested on hands-on skills associated with their craft.

Industrial Electrical Certified Plus Performance Verifications will be scheduled on an as needed basis. Please contact (361) 582-2528 for scheduling options.

This course is offered at the VC Emerging Technology Complex, Industrial Training Center, Room 121. Course length will depend on experience level, with a maximum of 4 hours allowable.

To take the written exam for Industrial Electrician Knowledge Verification, contact Shelley Callaway, Director of Education for IMSEF, at (361) 485-6839 or Shelley.Callaway@VictoriaCollege.edu.

*After successful completion of this course, you will receive an Institutional Certificate.

Millwright Level 1/2 Combo*

Prerequisite: NCCER Core Curriculum: Introductory Craft Skills

This course provides an introductory study of millwright. Topics include:

- Orientation to the trade
- Millwright hand tools
- Fasteners and anchors, gaskets, and O-rings
- Basic layout
- Oxy-fuel cutting
- Intermediate trade math
- Field sketching
- Intermediate blueprint reading
- Millwright power and specialty tools
- Setting base and soleplates
- Introduction to bearings

Millwright Level 3*

Prerequisite: Millwright Level 2

This course provides an advanced study of millwright. Topics include:

- Advanced trade math
- Precision measuring tools
- Installing packing and mechanical seals
- Removing and installing bearings and couplings
- Fabricating shims, alignment fixtures, and specialty jigs
- Pre-alignment for equipment installation
- Installing belt and chain drives
- Installing fans and blowers

Millwright Level 4*

Prerequisite: Millwright 3

This course provides an advanced study of millwright. Topics include:

- Conveyors
- Troubleshooting and repairing conveyors
- Conventional alignment
- Pumps
- Troubleshooting and repairing pumps
- Compressors and compressor maintenance
- Basic pneumatic systems
- Troubleshooting and repairing pneumatic equipment
- Basic hydraulic systems
- Troubleshooting and repairing hydraulic equipment
- Troubleshooting and repairing gearboxes.

Millwright Level 5*

Prerequisite: Millwright Level 4

This course provides an advanced study of millwright. Topics include:

- Performing reverse alignment
- Performing laser alignment
- Advanced blueprint reading
- Performing optical alignment
- Turbines
- Maintaining and repairing turbine equipment
- Installing electric motors
- Preventative and predictive maintenance
- Vibration analysis

Millwright Certified Plus Performance Verification

NCCER's Certified Plus certification requires both knowledge and performance verification. Participants will be tested on hands-on skills associated with their craft.

Millwright Certified Plus Performance Verifications will be scheduled on an as needed basis. Please contact (361) 582-2528 for scheduling options.

This course is offered at the VC Emerging Technology Complex, Industrial Training Center, Room 125. Course length will depend on experience level, with a maximum of 10 hours allowable.

To take the written exam for Millwright Knowledge Verification, contact Shelley Callaway, Director of Education for IMSEF, at (361) 485-6839 or Shelley.Callaway@VictoriaCollege.edu.

Pipefitting Level 1/2 Combo*

Prerequisite: NCCER Core Curriculum: Introductory Craft Skills

This course provides a beginner/intermediate study of pipefitting and combines certifications of both level 1 and 2. Topics include:

- Orientation to the trade
- Pipefitting hand tools
- Pipefitting power tools
- Oxyfuel cutting
- Ladders and scaffolds
- Motorized equipment
- Piping systems
- Drawings and detail sheets
- Identifying and installing valves
- Pipefitting trade math
- Threaded pipe fabrication
- Socket weld pipe fabrication
- Butt weld pipe fabrication
- Excavations
- Underground pipe installation

Pipefitting Level 3*

Prerequisite: Pipefitting 1/2 Combo

This intermediate course provides study in piping systems. Topics include:

- Rigging equipment
- Rigging practices
- Standards and specifications
- Advanced trade math
- Motorized equipment II
- Introduction to aboveground pipe installation
- Field routing and vessel trim
- Pipe hangers and supports
- Testing piping systems and equipment

Pipefitting Level 4*

Prerequisite: Pipefitting Level 3

This course provides an advanced study of pipefitting. Topics include:

- Advanced blueprint reading
- Advanced pipe fabrication
- Stress relieving and aligning
- Steam traps
- In-line specialties
- Special piping
- Hot taps
- Maintaining valves
- Introduction to supervisory roles

Plumbing Level 1*

Prerequisite: NCCER Core Curriculum: Introductory Craft Skills

This entry level course provides a study in plumbing systems. Topics include:

- Introduction to plumbing
- Safety
- Tools
- Plumbing math and drawings
- Plastic and copper pipe and fittings
- Cast iron and carbon steel pipe and fittings
- Fixtures and faucets
- DWV systems
- Water distribution systems

*After successful completion of this course, you will receive an Institutional Certificate.

Plumbing Level 2*

Prerequisite: Plumbing Level 1

This course provides an intermediate study in plumbing systems. Topics include:

- Plumbing math two
- Reading commercial drawings
- Structural penetrations
- Insulation and fire stopping
- Installing and testing DWV piping
- Installing roof, floor, and area drains
- Installing and testing water supply piping
- Types of valves
- Installing fixtures and valves
- Installing water heaters
- Basic electricity
- Fuel gas and fuel oil systems

Plumbing Level 3*

Prerequisite: Plumbing Level 2

This course provides an intermediate study of the plumbing trade. Topics include:

- Applied math
- Sizing water supply piping
- Potable water treatment
- Backflow preventers
- Types of venting
- Sizing DWV and storm systems
- Sewage pumps and sump pumps
- Corrosive-resistant waste piping
- Compressed air

Power Line Worker Level 1**

Prerequisite: NCCER Core Curriculum: Introductory Craft Skills

This course provides an introduction to the Power Line Worker trade.

Topics include:

- Power line worker safety
- Introduction to electrical circuits
- Introduction to electrical theory
- Climbing wooden poles
- Climbing structures other than wood
- Tools of the trade
- Aerial framing
- Utility service equipment
- Rigging
- Setting and pulling poles
- Trenching, excavating, and boring equipment
- Introduction to electrical test equipment.

**This class has additional admission requirements. Students will also need to purchase some tools.*

Power Line Worker Level 2*

Prerequisite: Power Line Worker Level 1

This course is an intermediate study of the Power Line Worker trade.

Topics include:

- Alternating current and three-phase systems
- Introduction to aerial distribution equipment
- Cable and conductor installation and removal
- Underground residential distribution systems (URDs)
- Overhead and URD service installations
- Distribution line maintenance

Power Line Worker Level 3*

Prerequisite: Power Line Worker Level 2

This course is an advanced study of the Power Line Worker trade.

Topics include:

- Introduction to substations
- Live line work
- Three-phase URD systems
- System protection and monitoring
- Troubleshooting
- Introduction to smart grid
- Fundamental skills for the crew leader

Scaffold Worker**

Prerequisite: NCCER Core Curriculum: Introductory Craft Skills

Topics include:

- Introduction to the trade
- Trade safety
- Trade tools and equipment
- Trade math
- Stationary scaffolds
- Mobile scaffolds
- Suspension scaffolds

Note – tuition includes the following tools: scaffold-builder ratchet, hammer, level, wire cutter, and tape measure.

**Students will need to purchase some tools for this class.*

Scaffolding Certified Plus Performance Verification

NCCER's Certified Plus certification requires both knowledge and performance verification. Participants will be tested on hands-on skills associated with their craft. Participants will need to provide a valid ID and will be required to bring their own tools and harnesses.

Scaffolding Certified Plus Performance Verifications will be scheduled on an as needed basis. Minimum class size is 2 participants. Please contact (361) 582-2528 for scheduling options.

This course is offered at the VC Emerging Technology Complex, Industrial Training Center, Room 121. Course length will depend on experience level, with a maximum of 7 hours allowable.

To take the written exam for Scaffolding Knowledge Verification, contact Shelley Callaway, Director of Education for IMSEF, at (361) 485-6839 or Shelley.Callaway@VictoriaCollege.edu.

Warehouse Vehicle Operations

This course will provide safety and operational training as well as hands-on practice in the use of forklifts, order pickers, reach trucks, and tuggers in a mock warehouse training environment. Successful trainees will be qualified by Health & Safety Training in the operation of these warehouse vehicles.

Topics include:

- Vehicle types
- Health & safety related to the operation of each type of equipment
- How to perform pre-user checks
- Maneuvering exercises
- Testing vehicle controls
- Lifting loads
- Operator risk assessment
- Safe operating procedures

Welding Level 1**

Prerequisite: NCCER Core Curriculum: Introductory Craft Skills

The course provides an introductory study of basic welding processes.

Students will demonstrate machine setup and complete welds and cutting operations. Topics include:

- Basic shop safety
- Identification of types of electrodes used in welding process
- Identifying various welding and cutting standards
- Oxy-fuel welding (OFW) and cutting
- Plasma arc cutting
- Air carbon arc cutting and gouging
- Shielded metal arc welding (SMAW)

**Students will need to purchase some Personal Protection Equipment (PPE) for this class.*

**After successful completion of this course, you will receive an Institutional Certificate.*

Welding Levels 2/3 Combo**

Prerequisite: Welding 1

This course is an intermediate study of welding and combines certifications for both Level 2 and 3. Students will demonstrate machine setup and complete welds and cutting operations. Topics include:

- Reading details drawings and welding symbols
- Stainless steel groove and pipe welds
- Air carbon arc cutting
- Plasma arc cutting (PAC)
- Gas metal arc welding (GMAW)
- Flux-cored arc welding (FCAW)
- Gas tungsten arc welding (GTAW)
- SMAW - open-root pipe welds
- GMAW - pipe
- FCAW - pipe
- GTAW - carbon steel pipe
- GTAW - low alloy and stainless steel pipe
- SMAW: stainless steel groove welds

*Students will need Personal Protection Equipment (PPE) required for level 1 plus additional PPE for levels 2 and 3.

Students who successfully complete NCCER Core Curriculum: Introductory Craft Skills, Welding Level 1, and Welding Levels 2/3 Combo will receive a CE Certificate

For more information:

www.VictoriaCollege.edu/WCE
(361) 582-2528
WCE@VictoriaCollege.edu

Law Enforcement Basic Peace Officer Course

(This course may be taken as credit or noncredit.)

The Certificate Program was developed to prepare students for a career as a Texas Peace Officer. The Victoria College Law Enforcement Academy meets the curriculum requirements for certification as a Basic Peace Officer from the Texas Commission on Law Enforcement (TCOLE). Students who successfully complete the program will be eligible to take the TCOLE licensing exam.

Admission Requirements

The Law Enforcement Academy is a selective admission program with a maximum enrollment of 24 students. The following are the minimum requirements to be qualified for admission into the Program:

1. The student must meet the admission requirements for Victoria College as stated in the current College Catalog. Contact Admissions & Records Office with questions.
2. The student must meet the minimum Reading, Writing and Math requirement on the National Police Officer Selection Test (POST).
3. Complete the Law Enforcement Academy Program application.
4. Satisfactory completion of the physical fitness test, psychological exam, physical exam, and criminal history check.
5. Provide a copy of Driver License Record (Type 3A).
6. Interview with Director of Law Enforcement Academy.

For more information:

www.VictoriaCollege.edu/LawEnforcement
(361) 572-6426

Motorcycle Safety**Basic Motorcycle Safety**

The Motorcycle Basic *RiderCourse* is designed with the beginner in mind, but experienced riders can also benefit from this course. Students will learn:

- how to operate a motorcycle
- best protective clothing to wear
- how to avoid dangerous situations

Students will finish the course at the two-year rider level, and the motorcycle is furnished. Successful completion of the Basic *RiderCourse* should waive the written and driving portions of the Texas DPS test for those 18 and over. Students less than 18 years of age will still need to take the TX DPS driving exam. All students are required to take a vision exam at the DPS office.

Prior to class, students are required to complete the MSF online eCourse. Cost of the eCourse is included in tuition.

For more information:

www.VictoriaCollege.edu/MotorcycleSafety
(361) 485-6830
Mary.Hardy@VictoriaCollege.edu

Real Estate

Victoria College offers courses, in partnership with The CE Shop, that can get you started in a career as a real estate sales agent or broker. Successful completion will enable you to apply for a Real Estate Salesperson License with the state of Texas.

To be eligible to apply for a real estate Salesperson License, an individual must be a citizen of the United States or a lawfully admitted alien, 18 years of age or older, and a legal resident of Texas. He/she must also furnish the Texas Real Estate Commission (TREC) satisfactory evidence of successfully completing the following education:

- Principles of Real Estate core real estate course (60 classroom hours)
- Law of Agency core real estate course (30 classroom hours)
- Law of Contracts core real estate course (30 classroom hours)
- An additional 3 related courses (90 classroom hours) acceptable to the Texas Real Estate Commission

Texas Real Estate Commission (TREC) now requires exams to be taken in the presence of a qualified, eligible Proctor to qualify for a certificate of completion. Additional fees may apply. Students are responsible for making their own arrangements for testing. For VC Testing Center services, please call (361) 582-2589.

TREC requires students with any criminal offenses, with unpaid judgment, who have had discipline taken against a professional or occupational license, or who have performed unlicensed activity to consider submitting a completed Moral Character Determination Form before applying for a license.

Both core and related courses are available through online instruction.

For more information:

www.VictoriaCollege.edu/RealEstate
(361) 582-2528
WCE@VictoriaCollege.edu

*After successful completion of this course, you will receive an Institutional Certificate.

Truck Driving*

Prerequisites: Valid Texas Class C Driver License; Valid Texas Class A Commercial Learner Permit (CLP) with no outstanding unpaid citations; Medical Examiner's Certificate and Medical Report; ability to pass a DOT physical, drug, and alcohol assessment.

Overview of the State of Texas Class A Commercial Driver's License written test. Includes preparation for mastery of the Commercial Driver's License written examination, general truck driving skills with hands-on component, and instruction coordinated with the Department of Transportation.

The Truck Driving course prepares persons for entry-level employment in the industry. At the conclusion of this course, students will successfully be able to demonstrate the safe operation and compliance with the law in various maneuvers of a commercial vehicle in different traffic situations, operate a tractor-trailer combination, and maneuver the vehicle safely frontward and backward around various obstacles. Student will take the Commercial Driver License driving examination at the Department of Public Safety as a class activity.

For more information:
www.VictoriaCollege.edu/WCE

VC Emerging Technology Complex, Victoria, TX
 Mary Hardy - (361) 485-6830
Mary.Hardy@VictoriaCollege.edu

VC Gonzales Center, Gonzales, TX
 Melissa Robinson - (830) 672-6251
Melissa.Robinson@VictoriaCollege.edu

Professional Continuing Education

If you are a professional who is already in the workforce and need to meet ongoing education requirements, or you want to improve your job skills, you can enroll in a variety of professional continuing education courses at Victoria College.

EPA Technician Certification
 Law Enforcement Training
 Real Estate

For more information:
WCE@VictoriaCollege.edu
 (361) 582-2528

*After successful completion of this course, you will receive an Institutional Certificate.

Allied Health Continuing Education (Noncredit)

Emergency Medical Service Professions (noncredit)

The Emergency Medical Service (EMS) Professions offer noncredit courses that lead to Emergency Care Attendant (ECA) and Emergency Medical Technician-Basic (EMT-B) certifications, as well as courses in Health Care Provider CPR; Basic Life Support (BLS), Advanced Cardiac Life Support (ACLS), HeartSaver First Aid, CPR, and AED, Pediatric Advanced Life Support (PALS), and International Trauma Life Support (ITLS).

For more information about the courses listed below, including specific course dates, times, and admission requirements, visit www.VictoriaCollege.edu/EMSTraining.

Emergency Care Attendant/First Responder

Emergency Care Attendants (ECA)/First Responders are trained to provide basic emergency medical care. They are likely to be the first people to arrive at the scene of an incident. Many volunteer firefighters, police officers, and other emergency workers are trained to this level. The ECA/First Responders represent the first component of the EMS system. Students successfully completing the ECA course are eligible to apply for certification with the Texas Department of State Health Services (DSHS) as an Emergency Care Attendant.

EMT-Basic

(This course may be taken as credit or noncredit.)

An EMT-B is trained to care for patients at the scene of an emergency and transport patients by ambulance to the hospital under medical direction. The EMT-B has the emergency skills to assess a patient's condition and manage respiratory, cardiac, and trauma emergencies. Students successfully completing the EMT-B lecture/lab course and the EMT-B clinical course are eligible to apply for certification as an Emergency Medical Technician-Basic with the Texas Department of State Health Services and National Registry of EMTs.

Basic Life Support (BLS) for Healthcare Providers-CPR

The Basic Life Support (BLS) for Healthcare Providers course is designed to provide a wide variety of healthcare professionals the ability to recognize several life-threatening emergencies; provide Cardiopulmonary Resuscitation (CPR); use an Automated External Defibrillator (AED); and relieve choking in a safe, timely, and effective manner.

Advanced Cardiac Life Support-ACLS

In this classroom-based course, providers enhance their skills in treating adult victims of cardiac arrest or other cardiopulmonary emergencies, while earning their American Heart Association ACLS for Healthcare Providers Course Completion Card. The course includes simulated clinical scenarios that encourage active, hands-on participation through learning stations where students practice essential skills individually, as part of a team, and as team leaders.

First Aid, CPR, and AED (Offered in both English and Spanish)

This course includes lecture, discussion, and skills practice following the current American Heart Association guidelines for CPR, cardiac arrest recognition, cardiac compressions, first aid, and use of Automated External Defibrillator. This class is designed for non-Healthcare Providers, including school teachers, athletic trainers, baby sitters, day care centers, volunteer responders, industrial and construction safety personnel, and other lay rescuers.

First Aid and CPR for Pets

This course offers basic first aid and CPR for Pets. Learn simple, basic care for your pet in an emergency. This class is designed for anyone who wants to learn how to keep their fur babies safe.

Pediatric Advanced Life Support-PALS

This course gives healthcare professionals the knowledge and skills to better recognize and treat critically ill infants and children. The course uses a scenario-based team approach to teach pediatric emergency management of pediatric patients approaching or already in respiratory or cardiac arrest.

International Trauma Life Support- ITLS

ITLS is accepted internationally as the standard training course for prehospital trauma care and is used as an essential curriculum in many paramedic, EMT, and first-responder training programs. This course combines classroom and hands-on skills stations.

For more information:

www.VictoriaCollege.edu/EMSTraining
(361) 582-2412
AHCE@VictoriaCollege.edu

Electrocardiogram (EKG) Technician

Victoria College offers a 64 hour Fundamentals of cardiovascular anatomy and physiology. Includes basic electrocardiography procedures, interpretation of basic dysrhythmias, and appropriate treatment modalities. Students will be able to describe the anatomy and physiology of the cardiovascular system, perform basic electrocardiography procedures, and interpret basic dysrhythmias. Upon successful completion of class, students will be eligible to sit for a national certification exam.

ADMISSION REQUIREMENTS

- Application to course

ELECTROCARDIOGRAM (EKG) TECHNICIAN CURRICULUM

ECRD 1011

For more information:

www.VictoriaCollege.edu/AlliedHealthCE
(361) 582-2412

Medical Assisting Program

Victoria College offers an introductory Medical Assisting Program designed for students to develop basic knowledge and skills necessary to function safely and effectively in a medical office/clinic environment. The 92-hour program consists of classroom work, class lab activities, and clinical practice observation in a medical office/clinic setting. Class maybe face-to-face, online, or combination.

ADMISSION REQUIREMENTS

- Application to program
- Tuition and textbook
- Required Immunizations (must be completed prior to enrollment)
 - 1-2 step PPD TB skin test
 - Hepatitis B Series
 - MMR
 - Varicella
 - Tdap (within last 10 years)
- Valid Pirate Portal email address
- Upon acceptance into program a criminal background check will be done using an outside agency

MEDICAL ASSISTING PROGRAM CURRICULUM

MDCA 1091

Upon successful completion of course, students will take a national certification exam and receive an Institutional Certificate.

For more information:

www.VictoriaCollege.edu/AlliedHealthCE
(361) 582-2412

Medical Coding

Victoria College offers a 90-training hour Medical Coding course face-to-face or online designed to provide the student skills and knowledge in the health information field for ICD-10 and CPT coding of insurance forms for reimbursement of medical services. This course emphasizes accurate ICD-10 and CPT coding of office procedures for payment/reimbursement by patient or third party and prevention of insurance fraud. Ideal learning outcomes for the course are to be able to identify different nomenclatures and classification systems and assign codes using appropriate rules, principles, guidelines, and conventions. Students will learn to describe and explain the differences/similarities among insurance plans. Upon successful completion of this course and meeting all requirements, student will be prepared to take a certification exam.

ADMISSION REQUIREMENTS

- Valid Pirate Portal email address

COURSE OBJECTIVES

- Discuss the relationship of accurate coding to reimbursement
- Apply appropriate principals for accurate claims processing
- Demonstrate appropriate use of ICD-CM, CPT, and HCPCS Coding Manuals
- Identify sources for changes in coding procedures

MEDICAL CODING CURRICULUM

POFM 1000

Upon successful completion of course, students will take a national certification exam and receive an Institutional Certificate.

For more information:

www.VictoriaCollege.edu/AlliedHealthCE
(361) 582-2412

Medication Aide Program

Victoria College offers a 140-hour Texas Department of Health and Human Services-approved Medication Aide course designed to prepare Nurse Aides to take the Texas Medication Aide Permit Examination. Nurse Aides who are on the State Registry and employed in long-term care and non-licensed direct care staff persons who have been employed 90 days in an approved facility are eligible to take the course. Coursework includes classroom, classroom laboratory, and clinical practice activity. Clinical practice is conducted in area long-term care agencies. Classes are taught on main campus as well as off-campus sites. Class may be face to face, online, or a combination of both.

ADMISSION REQUIREMENTS

- Application to program
- Tuition and textbook
- Certified copy of HS diploma or official transcript with graduation date or notarized copy of GED
- Nurse aide on state registry
- Student must be employed in a nursing home facility. Employment verification on letterhead required.
- \$25 money order payable to: Texas Department of Health and Human Services
- Valid email address

The required documents will be uploaded by the applicant into the CastleBranch website by the date indicated on the acceptance letter

PROGRAM CURRICULUM TOPICS

- Concepts of medication administration
- Basic pharmacology
- Effects of chemotherapeutic agents on the body systems
- Drug therapy for common disease processes
- Age-related variations to medication administration
- Role of the Medication Aide

MEDICATION AIDE PROGRAM CURRICULUM

NURA 1013 – Medication Administration for the Nurse Aide/Home Health Aide

NOTE: An average of 70% or better for coursework and completion of clinical assignment is required to pass. Upon successful completion of course, students will take a State Certification exam and receive an Institutional Certificate.

PROFESSIONAL DEVELOPMENT: MEDICATION AIDE

Victoria College offers the 7-hour Professional Development: Medication Aide for fulfillment of the annual education renewal requirements for the Medication Aide. Pre-registration is required.

MEDICATION ADMINISTRATION CONTINUING EDUCATION

NURA 1041 – Professional Development: Medication Aide

For more information:

www.VictoriaCollege.edu/AlliedHealthCE
(361) 582-2412

Mental Health Technician

Victoria College offers a 53 hour (including 5 observation hours) program designed to instruct and develop skills for the provision of basic care to mental health clients. Topics will include mental disorders, universal precautions, vital signs, observation and charting patient behavior, preventative management of aggressive behavior, patient rights, confidentiality, hygiene and communication. The clinical portion of this course is conducted in area mental health agencies. Course may be presented as face-to-face, online, or a combination

ADMISSION REQUIREMENTS

- Application to program
- Tuition and textbook
- Required Immunizations (must be completed prior to enrollment)
 - One - 2 Step PPD TB skin tests
 - Hepatitis B Series
 - MMR
 - Varicella
 - Tdap (within last 10 years)
 - COVID Vaccine or Exemption Status: The healthcare agencies are requiring all students to provide verification of COVID vaccine or an exemption status. All exemptions will be reviewed on an individual basis by VC's Advising & Counseling Services office.
- Valid Pirate Portal email address
- To be eligible to take the certification exam, you must be 18 and have a high school diploma or a GED.
- Upon acceptance into program a criminal background check will be done using an outside agency.

MENTAL HEALTH TECHNICIAN PROGRAM CURRICULUM

PMHS 1009

Upon successful completion of course, students will take a national certification exam and receive an Institutional Certificate.

For more information: (361) 582-2412
www.VictoriaCollege.edu/AlliedHealthCE

Nurse Aide Program

Victoria College offers a 60-hour Texas Department of Health and Human Services (HHS)-approved Nurse Aide designed to prepare the learner to function safely and effectively as a care provider in Long-Term Care facilities, the home, and other care settings. The classroom portion will be completed on your own time via a website provided by HHS. The clinical portion of the course is conducted in area healthcare agencies. The program is offered in several off-campus sites as well. Successful completion entitles the learner to a certificate of completion and the opportunity to take the Texas Nurse Aide Skills and Written Exams for placement on the Texas Nurse Aide Registry.

ADMISSION REQUIREMENTS

- Application to program
- Tuition and textbook
- Meet federal employability status
- Required Immunizations (must be completed prior to enrollment)
 - One - 2 Step PPD TB skin tests or annual TB test
 - Hepatitis B Series
 - MMR
 - Varicella
 - TDAP
- Valid email address
- Upon acceptance into program a criminal background check will be done using an outside agency

PROGRAM CURRICULUM TOPICS

- Introduction to health care systems
- Skills related to preparing for direct consumer care
- Skills related to activity and movement
- Skills related to hygiene
- Basic anatomy & physiology
- Measuring vital signs
- Skills related to body systems
- Care of the client in the home
- Care of clients with special needs

NURSE AIDE PROGRAM CURRICULUM

NURA 1060

NOTE: An average of 70% or better for coursework and a pass on clinical performance is required upon successful completion of course, students will take a State Certification exam, and earn an Institutional Certificate.

For more information:
www.VictoriaCollege.edu/AlliedHealthCE
 (361) 582-2412

Nurse Aide Program

Victoria College offers a 110-hour Texas Department of Health and Human Services-approved Nurse Aide designed to prepare the learner to function safely and effectively as a care provider in Long-Term Care facilities, the home, and other care settings. The classroom and nursing skills laboratory portion of the course are conducted on the Victoria College campus. The clinical portion of the course is conducted in area healthcare agencies. The program is offered in several off-campus sites as well. Successful completion entitles the learner to a certificate of completion and the opportunity to take the Texas Nurse Aide Skills and Written Exams for placement on the Texas Nurse Aide Registry.

ADMISSION REQUIREMENTS

- Application to program
- Tuition and textbook
- Meet federal employability status
- Required Immunizations (must be completed prior to enrollment)
 - One - 2 Step PPD TB skin tests or annual TB test
 - Hepatitis B Series
 - MMR
 - Varicella
 - TDAP
- Valid email address
- Upon acceptance into program a criminal background check will be done using an outside agency

PROGRAM CURRICULUM TOPICS

- Introduction to health care systems
- Skills related to preparing for direct consumer care
- Skills related to activity and movement
- Skills related to hygiene
- Basic anatomy & physiology
- Measuring vital signs
- Skills related to body systems
- Care of the client in the home
- Care of clients with special needs

NURSE AIDE PROGRAM CURRICULUM

NURA 1001
NURA 1060

NOTE: An average of 70% or better for coursework and a pass on clinical performance is required upon successful completion of course, students will take a State Certification exam, and earn an Institutional Certificate.

For more information:

www.VictoriaCollege.edu/AlliedHealthCE

Pharmacy Technician Program

Victoria College offers a comprehensive 64-hour program (which may include clinical observation hours) to prepare students to work as a pharmacy technician in a retail or other pharmacy setting and to take the Pharmacy Technician Certification exam. Course content includes pharmacy medical terminology, the history of pharmacy, the pharmacy practice in multiple environments, pharmacy calculations and measurements, reading and interpreting prescriptions, and defining drugs by generic and brand names. Through classroom lecture and hands-on labs, students will review dosage calculations, drug classifications, the "top 200 drugs," I.V. flow rates, sterile compounding, dose conversions, aseptic technique, the handling of sterile products, total parenteral nutrition (TPN), dispensing of prescriptions, inventory control, and billing and reimbursement. Class may be face to face, online, or combination.

ADMISSION REQUIREMENTS

- Application to program
- Upon acceptance a ten-panel drug screen will be required. Additionally, a FBI criminal background check will be completed as required by the Texas Board of Pharmacy: Which includes a Technician-in-training permit
- Tuition and textbook
- Required Immunizations (must be completed prior to enrollment)
 - One - 2 Step PPD TB skin tests
 - Hepatitis B Series
 - MMR
 - Varicella
 - Tdap (within last 10 years)

PHARMACY TECHNICIAN PROGRAM CURRICULUM

PHRA 1001

For more information:

www.VictoriaCollege.edu/AlliedHealthCE
(361) 582-2412

Phlebotomy

Victoria College offers a 122-training hour Phlebotomy course designed to develop skills in the performance of a variety of blood collection methods using proper techniques and universal precautions. The classroom and laboratory portions of the course are conducted on the Victoria College campus. Course maybe presented as face-to- face, online, or a combination. The clinical portion of the course is conducted in area healthcare agencies, clinics, private physicians' offices, and medical laboratory facilities.

ADMISSION REQUIREMENTS

- Application to program
- Tuition and textbook
- Required Immunizations (must be completed prior to enrollment)
 - One current TB test with negative results (TB skin test only valid for one year, must be valid through duration of course end date); or chest x-ray report within the last year clearly indicating no tuberculosis disease is present. In lieu of skin test, the Interferon-Gamma Release Assays (IGRAs) blood test can be accepted.
 - Hepatitis B Series
 - MMR
 - Varicella
 - Tdap (within last 10 years)
- Valid Pirate Portal email address
- Upon acceptance into the program a criminal background check will be done using an outside agency
- Immunization requirement and 10-panel drug screen

PROGRAM CURRICULUM TOPICS

- Proper patient identification techniques
- Specimen collection techniques - venipuncture
- Specimen collection techniques - capillary puncture

PHLEBOTOMY PROGRAM CURRICULUM

PLAB 1023

Upon successful completion of course, students will take a national certification exam and earn an Institutional Certificate.

For more information: (361) 582-2412
www.VictoriaCollege.edu/AlliedHealthCE

Veterinary Assistant Program

Victoria College offers a 36-hour program introducing students to the exciting and growing field of veterinary medicine. Students will learn about the care of animals as well as how to recognize signs of illness and disease. This program also covers interpersonal communication, interaction with clients and their animals, and how to assist the veterinarian during examinations. Administrative duties, such as fee collection, banking, and accounts payable, are also emphasized to provide the student with the skills necessary to maintain an efficient front office. Students will enjoy learning through classroom lecture as well as hands-on labs. Upon successful completion of class, students will take a national certification exam. Course maybe presented face-to-face, online, or a combination.

ADMISSION REQUIREMENTS

- Application to program
- Upon acceptance into the program a criminal background check will be done using an outside agency
- Tuition and textbook

VETERINARY ASSISTANT PROGRAM CURRICULUM

VTHT 1008

VTHT 1011

Upon successful completion of course, students will take a national certification exam and earn an Institutional Certificate.

For more information:

www.VictoriaCollege.edu/AlliedHealthCE
 (361) 582-2412

COVID Vaccination

Attention all prospective students, at the discretion of the healthcare facility, proof of COVID vaccination or exemption may be required. All exemptions will be reviewed and handled on an individual basis by VC's Advising & Counseling Services office.

Professional Continuing Education

If you are a professional who is already in the workforce and need to meet ongoing education requirements, or you want to improve your job skills, you can enroll in a variety of professional continuing education courses at Victoria College.

- Advanced Cardiac Life Support (ACLS)
- Pediatric Advanced Life Support (PALS)
- CPR Training
- Medication Aide Update

For more information:

www.VictoriaCollege.edu/AlliedHealthCE
 (361) 582-2412

Main Campus Contact Information**2200. E. Red River Street, Victoria TX 77901**

To meet the need for specialized training in a minimum amount of time, the College offers and/or can create a variety of short courses. For more information or to request specialized training, contact the appropriate office below:

Allied Health Building**Health Careers Office**

(361) 582-2412 • AHCE@VictoriaCollege.edu

Electrocardiogram (EKG) Technician

Medical Assisting

Medical Coding

Medication Aide for Nurse Aide

Medication Aide Update

Mental Health Technician

Nurse Aide

Pharmacy Technician

Phlebotomy

Veterinary Assistant

Emergency Medical Services Office

(361) 582-2412 Ricky.DeLaGarza@VictoriaCollege.edu

Advanced Cardiac Life Support

CPR Basic Life Support

Emergency Medical Technician – Basic

Emergency Care Attendant/First Responder

First Aid, CPR, and AED

First Aid, CPR for Pets

Pediatric Advanced Life Support

Emerging Technology Complex Contact Information**7403 Lone Tree Road, Victoria, TX 77905**

To meet the need for specialized training in a minimum amount of time, the College offers and/or can create a variety of short courses. For more information or to request specialized training, contact the appropriate office below:

Workforce & Continuing Education Department

(361) 582-2528 WCE@VictoriaCollege.edu

Business and Customer Service

Computer Applications

Language Skills

Legal Support Personnel Training

Personal Enrichment

Real Estate

Academy of Lifelong Learning

(361) 582-2520 WCE@VictoriaCollege.edu

Employee Training

(361) 582-2590 Nicole.Uresti@VictoriaCollege.edu

Industrial Training

(361) 582-2528 WCE@VictoriaCollege.edu

Automotive Service Excellence (ASE) Certification Testing

Carpentry

Construction Site Safety Technician (CSST)

Electrical

Fiber Optics

Heating, Ventilation, & Air Conditioning (HVAC)

Millwright

Pipefitting

Plumbing

Power Line Worker

Scaffold Worker

Warehouse Vehicle Operations

Welding

Public Service

(361) 572-6449 James.Martinez@VictoriaCollege.edu

Basic Telecommunicator

Law Enforcement Academy

Transportation

(361) 485-6830 Mary.Hardy@VictoriaCollege.edu

Motorcycle Safety

Truck Driving

All About VC

VC Locations

Gonzales, Texas

Victoria College Gonzales Center

424 E. Sarah DeWitt Drive • Gonzales, TX 78629 • (830) 672-6251

What is available?

- computer lab
- electrical labs
- faculty and staff offices
- heating, ventilation, & air conditioning lab
- interactive television (ITV)
- nursing lab
- science lab
- state-of-the-art classrooms and laboratories
- testing center
- learning lab
- welding lab
- wireless internet

What is offered?

A variety of classes, including allied health continuing education and vocational nursing, are offered in classroom, ITV, and online settings. The Academy of Lifelong Learning (ALL)-Gonzales is a member-driven organization for active adults. ALL offers members with common interests the opportunity to participate in lectures, discussions, social outings, and numerous different classes.

At the **Gonzales Workforce Training Center**, Commercial truck driving; NCCER core curriculum: introductory craft skills; electrical; heating, ventilation & air conditioning (HVAC); plumbing; and welding classes are currently offered.

This Center was opened in collaboration with the City of Gonzales and the Gonzales Economic Development Corporation.

Hallettsville, Texas

Victoria College Zelda L. Allen School of Nursing

1410 N. Texana Street • Hallettsville, TX 77964 • (361) 798-2289

What is available?

- computer lab
- faculty and staff offices
- interactive television (ITV)
- nursing lab

Victoria, Texas

Victoria College Emerging Technology Complex

7403 Lone Tree Road | Victoria, TX 77905 • (361) 580-3700

This state-of-the-art facility is comprised of a three-story Conference & Education Center and a two-story Industrial Training Center. Victoria County voters overwhelmingly approved a \$22 million general obligation bond in 2012 to support VC's master plan, which included construction of the Complex.

Conference & Education Center

The first two floors include a comprehensive conference facility, which offers 15 meeting spaces with comfortable, ergonomic furnishings; flexible meeting configurations; comprehensive and customizable meeting packages, and simple-but-flexible pricing. The large meeting hall inside the facility can accommodate banquet-, conference-, and auditorium-style seating for audiences of various sizes. The third floor includes classrooms, skills labs, and computer labs for training through VC's Workforce & Continuing Education Department, including the Academy of Lifelong Learning. The Law Enforcement Academy is also located at the Center.

Industrial Training Center

This building includes six high-bay training facilities and six associated classrooms on the second floor overlooking each of the bays for corporate and industrial training through VC's Workforce & Continuing Education Department. The Process Technology Program is also located at the Center.

Victoria College Liberty Street Industrial Training Center

1404 N. Liberty Street • Victoria, TX 77901

This facility currently houses corporate and industrial training through VC's Workforce & Continuing Education Department, including NCCER Carpentry, Pipefitting, and Plumbing.

Wireless (Wi-Fi) Buildings

The following main campus buildings offer Wi-Fi:

- Academic Building
- Allied Health Building
- Betsy Wright Building
- College Services & Training Building
- Continuing Education Center
- Fine Arts Building
- Health Sciences Center
- Johnson Hall
- Language Building
- Library
- Sports Center
- Student Success Center (under construction)
- Student Services Building
- Technology Center
- William Wood Building

Flexible Schedules

Flexible scheduling is an option for community college students. VC offers courses during the day or evening as well as via distance education:

- Online (ONL)
- Real-time remote (WBX)
- Alternating (ALT)
- Hybrid (HYB)
- Interactive television video (ITV)

For more information about distance education courses, contact the Institutional Effectiveness and Learning Technologies Office at (361) 485-6842 or via email to IELT@VictoriaCollege.edu.

Workforce & Continuing Education

Victoria College offers a variety of workforce and continuing education courses and programs designed to meet the needs of the community. From customized training to lifelong learning activities, Victoria College Workforce & Continuing Education provides businesses, industries, and individuals the opportunity to learn or improve technical and professional competencies, along with vocational and recreational classes for personal enrichment.

Workshops, seminars, and institutes can be planned to meet needs of specific groups. In such cases, Continuing Education Units (CEUs) may be awarded to participants. For more information, contact the Workforce & Continuing Education Department at (361) 582-2528 or via email to WCE@VictoriaCollege.edu.

Cultural Enrichment

Victoria College offers a wide range of programs and facilities for cultural enrichment and community service for students and the community:

- Museum of the Coastal Bend
- Leo J. Welder Center for the Performing Arts
- VC Fine Arts Gallery
- Musical productions and art exhibits
- John W. Stormont Lectures
- Lyceum Lecture Series
- and much more

The Emerging Technology Complex, Johnson Symposium, Leo J. Welder Center for the Performing Arts, Museum of the Coastal Bend, Student Success Center (under construction), and the VC Library are college facilities that are frequently utilized by the public.

Leading the Way

Victoria College Board of Trustees

V. Bland Proctor, District 3, Term expires in 2026	Chair
Luis A. Guerra, District 2, Term expires in 2030.....	Vice Chair
John E. Zacek, District 4, Term expires in 2028.....	Secretary
Daniel A. Cano MD, District 7, Term Expires 2026	Member
Catherine R. McHaney, District 6, Term expires in 2028.....	Member
Josie Rivera, EdD District 1, Term expires in 2030.....	Member
Ronald B. Walker, District 5, Term expires in 2026	Member

Administrative Council

Jennifer Kent, EdD	President
Cindy Buchholz, MA	Executive Vice President-Chief Academic Officer
Keith Blundell, MBA, CPA	Vice President, Administrative Services
Marisa Pierce, EdD.....	Vice President, Student Services
Terri Kurtz, BBA	Executive Director, Human Resources & Affirmative Action Officer

Instructional Council

Betsy Crane, EdD	Dean, Division of Career & Technical Education
Jacob Flores, MA	Dean, Division of Arts, Humanities, & Social Sciences
Matthew Weiler, MS	Dean, Division of Science, Mathematics, Engineering, & Physical Education
Babette Lowe, MAIS	Dean, Division of Academic Support & Student Success
Vince Ortiz, BA	Manager, Gonzales Center
Jennifer Stewart, MS	Director, Library
Darla Strother, BSN, MSN	Dean, Division of Allied Health
Matt Wiley, MS, MBA	Director, Institutional Effectiveness & Learning Technologies

Directors

Bobby Cubriel, MS	Director, Advising, Counseling, & Support Services
Marty Deckard, MA, MBA	Director, Physical Plant
Elaine Everett-Hensley, BBA	Director, Student Center & Student Life
Andy Fariior, MS	Director, Technology Services
Shari Gould, BSN, MSN	Director, Allied Health Continuing Education
Tiffany Johnson, MAIS.....	Director, Adult Education
Sophia Kameitjo, MS	Director, Grants Administration
Darin Kazmir, BBA	Director, Marketing & Communications
Brittany Mace, MBA	Director, Financing
Dwayne Maly, BS.....	Director of Industrial Programs
James Martinez, MAIS	Director, Law Enforcement Academy
Melinda Mendoza, MEd.....	Director, Financial Aid
Amy Mundy, BA	Executive Director, College Advancement & Victoria College Foundation
Rachel Nessel, MEd	Director, Workforce & Continuing Education
Pam Neuman, MEd	Director, KEY Center
Sue Prudhomme, BBA	Executive Director, Cultural Affairs
Susan Prukop, BS	Director, Development
Donna Rodriguez, BBA	Director, Testing Center
Sabrina Romo, MEd	Director, Enrollment Services
Madelyne Tolliver, MA.....	Director, Admissions & Registrar
Kaleena Trevino, BS.....	Director, Purchasing

Educated by the Best

Victoria College Faculty

Aguilar, Alfredo--History

BA, MA University of Texas, Pan American; PhD, Texas Tech University

Ajrami, Heidi - English

BA, Mercer University – Atlanta; MA, University of Nebraska – Omaha

Azbill, E. Morris - English, Professor Emeritus

MA, Sul Ross State University

Balli, Melissa - Music Coordinator

BM, Texas A&M International University; MA, MM, West Texas A&M University

Berkovsky, Sherie - Vocation Nursing Program-Gonzales

BSN, The University of Texas at Arlington

Borghain, Devoni - Associate Degree Nursing

BSN, MSN, Texas Tech University Health Science Center

Bradley, Chelsea - Psychology

BS, MS, Tarleton State University

Buchholz, Cindy - Executive Vice President-Chief Academic Officer

BA, MA, University of Houston – Victoria

Byerly, Edward A. - History/Geography

BA, University of Northern Colorado; MA, Western Illinois University; PhD, Arizona State University

Carrasco, Jennifer - English

BA, MEd, MAIS, University of Houston – Victoria

Chavez, Salomon - Process Technology

AAS, Texas State Technical Institute

Clegg, Sherre - Strategic Learning

BA, MA, Florida Atlantic University

Artiga, Marisol - Physical Therapist Assistant Program

AAS, Victoria College

Crane, Betsy - Dean, Division of Career & Technical Education

BBA, MBA, University of Houston – Victoria; EdD, Texas Tech University

Crislip-Baker, Deborah - Department Chair, Strategic Learning

BA, Glenville State College; MA, Shepherd University; EdD, University of Houston

Croisant, Michael - Chemistry

BS, Purdue University; MS, University of Wisconsin – Madison

DeVries, Lisa - English

BA, MA, East Carolina University

DeVries, Peter - Biology

BS, University of California; MS, California Polytechnic University

Dvorak, Helen - Director, Distance Education & Instructional Technology

BS, MAIS, University of Houston – Victoria; EdD, Texas Tech University

Elsik, Lisa - Psychology

BA, MS, Texas A&M – Kingsville

Espinoza, G. Janelle - Department Chair, Science

AS, Jackson State Community College; BS, PhD, Texas A&M at Galveston

Fletcher, Marylynn L. - Fine Arts, Professor Emeritus

BM, Indiana University; MM, DMA, University of Texas – Austin

Flores, Jacob Z. - Dean, Division of Arts, Humanities, & Social Sciences

BA, MA, St. Mary's University – San Antonio

Foester, Susan - Mathematics

BS, Texas A&M University; MA, University of Houston

Frolick, Tanya - Speech

BA, MAIS, University of Houston-Victoria

Gould, Jeremy - Computer Information Systems

AAS, Victoria College; BS, Walden University

Gould, Shari - Director, Allied Health Continuing Education

AAS, Excelsior University; BSN, MSN, RN - Walden University

Grizzle, Earline - Speech, Professor Emeritus

MA, University of Houston

Gyamera-Acheampong, Charles - Biology and Chemistry

BSc, Biochemistry, University of Science & Technology; MSc, University of Tromso; PhD, University of Ottawa

Hagan, Karen - Department Chair, Social Sciences

BA, Skidmore; MA, University of Virginia; PhD, Louisiana State University

Hall, Gary Dean - English

BA, MA, Sam Houston State University

Hamilton, Jerry Wayne - Biology and Chemistry, Professor Emeritus

BS, MEd, Southwest Texas State University

Harper, Joyce - Program Chair, Vocational Nursing Program

AAS, Victoria College; BSN, Texas Tech University Health Science Center; MSN, University of Texas – Arlington

Heinold, Katrina - Vocation Nursing Program-Victoria

AAS, Victoria College; BSN, University of Texas-Arlington

Henry, Mark - Business Management, Professor Emeritus

BBA, MBA, Texas A&I University Kingsville

Hewig, Alison - Associate Degree Nursing

BSN, University of Texas – Austin; MSN, University of Phoenix

Hill, Brandy - Department Chair, Business and Computer Programs

BBA, MS, Texas State University

Hill, Calvin - Physics

BS, MS, University of Central Oklahoma

Hoblit, Karen - Psychology, Professor Emeritus

BS, University of the State of New York; MS, Southwestern Oklahoma State University; EdD, Southeastern University

Hodde, Robert B. - Department Chair, Fine Arts

BA, MA, Southwest Texas State University; MA, Stephen F. Austin State University

Hummel, Michael D. - History, Professor Emeritus

BA, MA, Baylor University; PhD, North Texas State University

Hutcheson, Brian - Mathematics

BS, Southwest Texas State University; MEd, Texas State University

Hyak, Sharon - Biology

BS, University of Houston – Victoria; MS, University of Nebraska – Kearney; EdD, Kansas State University

Janowski-Bell, Margaret - Biology

BS, University of Texas – San Antonio; MS, Midwestern State University; PhD, University of Missouri – Columbia

Jechow, Donna “Susie” - EMS Coordinator

BS, Sul Ross State University

Johnson, Bradley - Mathematics

AS, SUNY Jefferson Community College; BA, SUNY Plattsburgh; MS, University of Oklahoma

Kallus, Chris E. - Respiratory Care, Professor Emeritus

RRT, BS, Southwest Texas State University; MEd, University of Houston – Victoria

Kapp, Ann - History

BA, University of Texas – Austin; MA, Texas State University – San Marcos

Kinto, Kelly - Government

BA, Lamar University; MA, Sam Houston State University; JD, Texas Tech University School of Law

Knezek, Lillian - English

BA, Texas Woman's University; MA, Texas Christian University

Lahodny, Deedra - Vocational Nursing Program-Coordinator Hallettsville

ADN, Baptist School of Health Professions; BSN, MSN, University of Texas – Arlington

Langley, Amanda - Vocation Nursing Program-Victoria

AAS, Victoria College

Li, Rachel - Economics

BS, Henan University; MS, Huazhong Univeristy; MS, Tarleton State; PhD, Huazhong University of Science and Technology

Lowe, Babette - Dean, Division of Academic Support and Student Success

BS, MAIS, University of Houston – Victoria

Lowrie, Tracy - Associate Degree Nursing

MSN, Texas A&M University – Corpus Christi

Malone, Alyssa K. - Mathematics

BA, BS, University of Texas of the Permian Basin; MS, Texas Christian University

Marshall, Bridgette S. - Department Chair, Humanities

BS, MAIS, MEd, University of Houston – Victoria

Martinez, James A. - Criminal Justice

BS, MAIS, University of Houston – Victoria

Mason, Emily - Department Chair, Physical Education/Wellness Coordinator

BS, University of Texas Permian Basin; MS, Texas Woman's University; PhD, University of New Mexico

Mason, Patrick - Instrumentation & Electronics

AAS, Victoria College

Mata, Juan - Associate Degree Nursing

AAS, University of Texas Pan American; BSN, Texas Tech University Health Science Center; MSN, Our Lady of the Lake University

Mayes, Mary - Physical Education, Professor Emeritus

BS, Southwest Texas State University; MS, Texas A&M University – Corpus Christi

McAlister, Sonya - Art

BA, Mars Hill University; MFA, University of Florida

McClure, Kim - Associate Degree Nursing

AAS, Victoria College; BSN, Texas Tech University Health Science Center; MSN, Walden University

Miessler, Cy - Music

BA, Indiana University--Bloomington; MM, Arizona State University; DMA, University of Texas – Austin

Mikulik, Tammy - Physical Therapist Assistant Program Director

BS, UT Health Science Center - San Antonio; DPT, Hardin – Simmons University

Moreno, Irma - Program Chair, Associate Degree Nursing

AAS, Victoria College; BSN, MSN, University of Houston – Victoria

Murphy, Joseph Daniel - Mathematics, Professor Emeritus

BS, Texas A&M University; MEd, University of Houston – Victoria

Neumann, Shai - Mathematics

BA, Tel Aviv University; MS, Texas Tech University

Nix, Nacona - Government

BA, Stephen F. Austin State University; MA, University of North Carolina at Chapel Hill

Oldmixon, Cecilia - Program Chair-Respiratory Care

RRT, AAS, Victoria College; BAAS, University of Houston – Victoria; MAEd, University of Phoenix

Olsovsky, Mark - Instrumentation & Electronics

BS, Texas A & I

Pagel, Diana - Mathematics, Professor Emeritus

BA, Incarnate Word College; MS, St. Mary's University; MS, Texas A&M University – Corpus Christi

Patterson, Rebekah - Coordinator-Vocational Nursing-Victoria

AAS, San Antonio Collete; BSN, Schreiner University

Paulsen, Michelle - English

BA, MA, University of Illinois

Pedraza, Deborah - Engineering and Mathematics

PhD, Texas Tech University; MS, University of Massachusetts – Amherst; MBA, University of Houston – Victoria; BS, University of Houston – Victoria

Pena, Debbie - Associate Degree Nursing

AAS, Victoria College; BAAS, University of Houston – Victoria; BSN, MSN; University of Texas A&M – Corpus Christi

Pfeil, Kristi - Associate Degree Nursing

AAS, Victoria College; BSN, Texas Tech University Health Science Center; MSN, Walden University

Poole, Lesley - Associate Degree Nursing

AAS, Victoria College; BSN, MSN, Western Governors University

Reed, Jenny - Art

BFA, Northern Kentucky University; MFA, Indiana University

Robinson, Jacquelyn - English

BA, University of Texas; MA, University of Houston – Victoria

Scotten, Joshua - Instrumentation & Electronics

AAS, Victoria College

Sekul, Joseph D. - Government

BS, St. Joseph's University; MA, The College of William and Mary in Virginia; PhD, University of Texas – Austin

Settles, Jo Anne - Associate Degree Nursing

BSN, Texas Woman's University; MSN, University of Texas Health Science Center – San Antonio

Stahoviak, Mary K. - English, Professor Emeritus

BA, University of Texas – Austin; MA, University of Houston – Victoria

Steele, Tracy - Vocational Nursing Program-Hallettsville

BSN, Galen College of Nursing

Stendebach, Steven - English/Humanities

BA, Baker University; MA, Creighton University; PhD, Bowling Green State University

Stevens, Sharon - Associate Degree Nursing

MS, Walden University

Storey, Patricia-Vocational Nursing-Gonzales

AAS, Galen School of Nursing; BSN, Galen School of Nursing

Strother, Darla - Dean of Allied Health/Director of Nursing

AAS, Victoria College; BSN, MSN, RN, Texas Tech University Health Science Center

Sturm, Corey - Biology

MS, University of Nebraska, Kearny; BS, University of Houston – Victoria

Sullivan, Susan - Associate Degree Nursing

BA, University of North Texas; BSN, Texas Woman's University; MSN, Texas A & M University – Corpus Christi

Swickheimer, Dave - Computer Information Systems

BA, University of Texas – Austin; MS, Texas A&M University – Corpus Christi

Thomason, Charles P. – Instrumentation & Electronics

AAS, Texas State Technical Institute

Ulbrich, Michelle - Associate Degree Nursing

BSN, Texas A & M University – Corpus Christi; MSN, The University of New Mexico

Valdez, Jon James - Respiratory Care

MS, Texas State University

Van Beveren, Nadine - Associate Degree Nursing

BSN, Texas Woman's University; MSN, University of Phoenix

Vrana, Wade - Department Chair, Industrial Programs
AAS, Coastal Bend College; BAAS, Texas State University

Wagner, Harry A., III - Geology, Professor Emeritus
BS, MS, University of Texas – El Paso

Weiler, Matthew - Dean, Division of Science, Mathematics, Engineering, & Physical Education
BS, MS, South Dakota School of Mines and Technology

White, William David - Mathematics, Physics, Professor Emeritus
BS, MS, Southwest Texas State University

Wick, Lawrence - Process Technology
BS, Texas A&M University; MEd Texas A&M University

Wiley, Gerry “Matt” - Director, Institutional Effectiveness and Learning Technologies
BS, MS, University of California Riverside; MBA, Texas A&M University – Corpus Christi

Wilkinson, Racheal - Psychology
BS, MS, Texas A & M University – Commerce

Williams, Jeffery - Biology and Chemistry
BA, Brigham Young University (Provo, UT); PhD, University of Texas – Austin

Winkenwerder, Rachel A. - Mathematics
BS, University of Houston – Victoria; MEd, Texas State University – San Marcos

Yosko, Melanie - Department Chair, Mathematics & Engineering
BA, MS, Texas A&M University

History of VC

Victoria College was established as a part of the Victoria Independent School District in 1925, making it one of the oldest community colleges in Texas. Classes were initially held on the third floor of the Patti Welder High School with 51 students enrolling that first semester.

In Sept. 1949, VC moved to our present-day Main Campus on Red River Street and constructed four buildings that year.

Nearly a century later, VC has grown to include 16 buildings on our 60-acre Main Campus and has expanded operations to include the Zelda L. Allen School of Nursing in Hallettsville in 1984; the Museum of the Coastal Bend in 2003; the Gonzales Center in 2006; the Leo J. Welder Center for the Performing Arts in downtown Victoria in 2012; the Liberty Street Industrial Training Center in 2012; and the Emerging Technology Complex on Lone Tree Road in 2015.

Over the years, VC has undergone several name changes; expanded our workforce training, adult education, and dual enrollment offerings; and evolved into a thriving community college that now serves approximately 6,200 students each year.

In 2025, we will commemorate 100 years of providing quality education and training to all who live and work in the Crossroads of South Texas.

Main Campus Buildings

Academic Building

The Academic Building is a two-story structure with general academic classrooms, two interactive television classrooms, a computer lab, and the Corporate Training Room. Also located in this building are the Vice President of Administrative Services, Business Office, Institutional Effectiveness and Learning Technologies Director, Purchasing Office, and Police & Campus Safety Office.

Allied Health Building

The Allied Health Building is the instructional center for the Allied Health & Public Service programs. The building also contains the Johnson Symposium which is utilized for a variety of ceremonies and college productions, an interactive television classroom, and a computer lab.

Betsy Wright Building

The Betsy Wright Building houses two conference rooms and a soundproof recording studio. The Human Resources Office is housed in this building.

College Services & Training Building

The College Services & Training Building houses the Marketing & Communications Department (including the mailroom) and the Offices of the Physical Plant. It also houses a multi-purpose classroom, and a heating, ventilation, and air conditioning (HVAC) lab.

Continuing Education Center

The Continuing Education Center is a two-story structure with classrooms and computer labs. Also located in this building are Adult Education, the Testing Center, and Citizens Convenient Care at Victoria College.

Fine Arts Building

The Fine Arts Building houses classrooms, studios, band hall, choir room, practice rooms, an art gallery, and office space for the Music, Art, Drama, and Speech Departments.

Health Sciences Center

The Health Sciences Center houses 15 classrooms and lecture halls, 18 laboratories, 6 study halls, 2 computer labs, a learning lab and a resource center, four state-of-the-art simulation centers, conference facilities and faculty offices, a commons area with a coffee bar, and a life-size fossil exhibit.

The Health Sciences Center was constructed utilizing funds approved in May 2006 by Victoria County voters in a \$15.5 million tax bond issue. The project was initiated by a challenge grant from The M.G. and Lillie A. Johnson Foundation. Furnishings and equipment were funded by the generosity of individuals, foundations, and businesses in the college service area.

Johnson Hall

Johnson Hall is equipped with classrooms for a variety of college courses and programs. The Offices of the Executive Vice President-Chief Academic Officer; Vice President of Student Services; Academic Support and Student Success Division; Institutional Effectiveness and Learning Technologies; and faculty. Also located in this building are Student Support Services (KEY Center), the Learning Lab, Success Coaching, and the Veterans Center.

Language Building

The Language Building contains classrooms and faculty offices for a variety of college courses in the Humanities and Social Sciences departments. There is also a computer lab located on the first floor of the building.

Library Building

The Library Building occupies a four-story building on the western end of campus. The VC Bookstore, VC Library, and Student Life are housed in this building. Building hours are Monday-Friday, 8 a.m. to 5 p.m. Evening and weekend library hours are available at the UHV Library located on Ben Wilson.

The basement houses Student Life, a recreational zone, a lecture hall, and the Museum Archaeology Lab.

The first floor houses the VC Bookstore, a student lounge, and a meeting room. The Bookstore serves the students, faculty, and staff of Victoria College. The Bookstore has been established to provide books, supplies, and other related materials essential to meet the educational mission of the institutions it serves.

The second floor houses the VC Library, a computer lab, study rooms, and Markerspace. More than 20 computer workstations provide access to the internet, library electronic databases, and a selection of Microsoft Office applications. Other library features include conference and study rooms, study carrels and tables, leisure reading areas, and a copier.

The college librarian and other library staff are available to assist in locating information and using the library's resources. Interlibrary Loan is available to all students, faculty, and staff to help them acquire the materials they need. The library also has a full program of bibliographic instruction to help students learn to do quality research and citations.

The library's main collection contains over 12,000 print volumes and over 20,000 subscriptions to ebooks and electronic journals. There is a sizable leisure reading collection of books and graphic novels, as well as an audiovisual collection featuring over 1,500 feature and educational films on DVD as well as hundreds of music CDs. Films and music can also be streamed online via the library databases. The library also participates in Interlibrary Loan and has a reciprocal agreement with UHV giving students, faculty, and staff full privileges at their library.

Museum of the Coastal Bend

The Museum of the Coastal Bend serves the general public, tourists, college and university students, and in particular, the kindergarten through 12th-grade students in Victoria and surrounding counties. The mission of the Museum of the Coastal Bend is to enhance the appreciation and enjoyment of the region's heritage. The purpose of the museum is four-fold: to collect, to preserve, to exhibit, and to interpret the history and heritage of the region. For more information visit www.MuseumoftheCoastalBend.org.

Sports Center

The Sports Center features one basketball court; two volleyball courts; aerobics room; fitness room; dressing facilities for students, faculty, and staff; and faculty offices.

Student Success Center (Under Construction)

The three-story expansion and renovation of the existing Student Center will provide students with access to admissions, advising, support services, a library, bookstore, and other resources in one, central campus location.

Student Services Building

The Student Services Building houses the Offices of the Admissions & Records, Advising & Counseling Services, Communication Center, Enrollment Services, Financial Aid, Grants Administration, Payments Office, Victoria College Foundation, Victoria College President, and the Welcome Center.

Technology Center

The Technology Center houses state-of-the-art computer labs, classrooms, and faculty offices. Technology support and Cafe Espresso are also located in the building.

William A. Wood Building

The William A. Wood Building houses laboratories for instrumentation and electronics, and welding. Each lab is outfitted with the latest machines, tools, computers, and equipment to provide students an opportunity for training that meets current industry requirements.

(This page left blank intentionally)

Students will be able to progress more quickly to and through college-level math classes using the Non-Course Competency-Based Options (NCBOs) MATH 0014, MATH 0024, MATH 0032, and MATH 0042. See course descriptions for more details about the NCBOs.

Math Pathways

MATH Pathway based on TSIA 1.0 scores

TSI Scores	310-335 & ABE 1-4*			
	Algebraic/Calculus Pathway			NonAlgebraic Pathway
First Semester	MATH 0300			MATH 0300
Second Semester	MATH 0401			MATH 1332+0032 MATH 1342+0042
Third Semester	MATH 0314+MATH 1314		MATH 1324+0024	
Fourth Semester	1-4 Semesters of PreCalculus/Calculus depending on degree.	MATH 1316	Business Calculus/Statistics	
Fifth and beyond		1-4 Semesters of PreCalculus/Calculus depending on degree.		

TSI Scores	310-335 & ABE 5-6*			
	Algebraic/Calculus Pathway			NonAlgebraic Pathway
First Semester	MATH 0314+MATH 1314		MATH 1324+0024	MATH 1332+0032 MATH 1342+0042
Second Semester	1-4 Semesters of PreCalculus/Calculus depending on degree.	MATH 1316	Business Calculus/Statistics	
Third Semester and beyond		1-4 Semesters of PreCalculus/Calculus depending on degree.		

TSI Scores	336-342*			
	Algebraic/Calculus Pathway			NonAlgebraic Pathway
First Semester	MATH 0314+MATH 1314		MATH 1324+0024	MATH 1332+0032 MATH 1342+0042
Second Semester	1-4 Semesters of PreCalculus/Calculus depending on degree.	MATH 1316	Business Calculus/Statistics	
Third Semester and beyond		1-4 Semesters of PreCalculus/Calculus depending on degree.		

TSI Scores	TSI Complete: 350+			
	Algebraic/Calculus Pathway			NonAlgebraic Pathway
First Semester	MATH 1314	MATH 1324	MATH 1316	MATH 1332 MATH 1342
Second Semester and beyond	MATH 1316 -- OR -- 1-4 Semesters of PreCalculus/Calculus depending on degree.	Business Calculus/Statistics	1-4 Semesters of PreCalculus/Calculus depending on degree.	

*Students, if your score on the math section of the TSIA exam version 1 is less than 350, please consult an advisor for guidance with these pathways.

MATH PATHWAYS
MATH Pathway based on TSIA 2.0 scores

TSI Scores 2.0	Below 950 & Diagnostic Level 1-2*		
	Algebraic/Calculus Pathway		NonAlgebraic Pathway
First Semester	MATH 0300		MATH 0300
Second Semester	MATH 0401		MATH 1332+0032 MATH 1342+0042
Third Semester	MATH 0314+MATH 1314	MATH 1324+0024	
Fourth Semester	1-4 Semesters of PreCalculus/Calculus depending on degree.	MATH 1316	Business Calculus/Statistics
Fifth and beyond		1-4 Semesters of PreCalculus/Calculus depending on degree.	

NOTE: THECB recommends students with these scores choose a NonAlgebraic pathway

TSI Scores 2.0	Below 950 & Diagnostic Level 3-4*		
	Algebraic/Calculus Pathway		NonAlgebraic Pathway
First Semester	MATH 0401		MATH 1332+0032 MATH 1342+0042
Second Semester	MATH 0314+MATH 1314	MATH 1324+0024	
Third Semester	1-4 Semesters of PreCalculus/Calculus depending on degree.	MATH 1316	Business Calculus/Statistics
Fourth Semester and beyond		1-4 Semesters of PreCalculus/Calculus depending on degree.	

NOTE: THECB recommends students with these scores choose a NonAlgebraic pathway

TSI Scores 2.0	Below 950 & Diagnostic Level 5 & BPA 0*		
	Algebraic/Calculus Pathway		NonAlgebraic Pathway
First Semester	MATH 0314+MATH 1314	MATH 1324+0024	MATH 1332+0032 MATH 1342+0042
Second Semester	1-4 Semesters of PreCalculus/Calculus depending on degree.	MATH 1316	Business Calculus/Statistics
Third Semester and beyond		1-4 Semesters of PreCalculus/Calculus depending on degree.	

TSI Scores 2.0	Below 950 & Diagnostic Level 5 & BPA 1-4*		
	Algebraic/Calculus Pathway		NonAlgebraic Pathway
First Semester	MATH 1314+0014	MATH 0314+MATH 1314	MATH 1324+0024
Second Semester and beyond	MATH 1316 -- OR -- 1-4 Semesters of PreCalculus/Calculus depending on degree.	MATH 1316 -- OR -- 1-4 Semesters of PreCalculus/Calculus depending on degree.	MATH 1324+0024 Business Calculus/Statistics

TSI Scores 2.0	TSI Complete: [950+] --OR-- [Below 950 & Diagnostic Level 6]		
	Algebraic/Calculus Pathway		NonAlgebraic Pathway
First Semester	MATH 1314	MATH 1316	MATH 1324
Second Semester and beyond	MATH 1316 -- OR -- 1-4 Semesters of PreCalculus/Calculus depending on degree.	1-4 Semesters of PreCalculus/Calculus depending on degree.	Business Calculus/Statistics

*Students, if your score on the math section of the TSIA exam version 2 is less than 950, please consult an advisor for guidance with these pathways.

(This page left blank intentionally)

Reading and Writing Pathways

Reading and Writing Pathways

Pairing courses helps students become college-ready and complete their first college-level course as quickly as possible, while providing essential academic support. Please see the course descriptions for more details about course-based and Non-Course Based Options (NCBOs) pairing options.

Assessment: TSIA

TSIA Placement Chart

Writing: At least 340 and TSI essay score at least a 4; or less than 340 and an ABE Diagnostic of at least a 4 and essay score at least a 5 = TSI complete in writing

If writing is the lower score:

ABE	Score	Essay	Essay
1-4	<340	1-4	INRW 0016 + INRW 0301
5-6	<340	1-4	INRW 0301 + Gateway course
	338-339	4-5	INRW 0017 + Gateway course
Gateway course for writing deficiency: ENGL 1301, ENGL 2311, or HUMA 1301			
Students who are not TSI complete are only allowed to enroll in one corresponding gateway course (the co-requisite course) until they are TSI complete.			

Reading: TSI reading score of 351 or higher = TSI complete in reading

If reading is the lower score:

ABE	Score	Essay	Essay
1-4	310-341	1-4	INRW 0016 + INRW 0301
5-6	310-341	1-2	INRW 0301 + ENGL 1301
5-6	310-341	3-5	INRW 0301 + Gateway course
	342-348	n/a	INRW 0301+ Gateway course
	349-350	n/a	INRW 0017 + Gateway course
Gateway courses for reading deficiency: ENGL 1301, ENGL 2311, HUMA 1301			
Students who are not TSI complete are only allowed to enroll in one corresponding gateway course (the co-requisite course) until they are TSI complete.			

Assessment: TSIA 2 (effective January 11, 2021)

TSIA 2 INRW Placement Chart

Test Score	Diagnostic Level	Essay	Classes Needed	TSI Status
> 945	n/a	>5	college ready	TSI complete in both reading and writing
<945	>5	>5	college ready	TSI complete in both reading and writing
> 945	n/a	4	INRW 0017 + co-requisite	Students who pass the co-requisite course are TSI complete in both reading and writing.

Test Score	Diagnostic Level	Essay	Classes Needed	TSI Status
> 945	n/a	1-3	INRW 0301 + co-requisite	Students who pass INRW 0301 and or the co-requisite course are TSI complete in both reading and writing.
<945	4-6	1-4	INRW 0301 + co-requisite	Students who pass INRW 0301 and or the co-requisite course are TSI complete in both reading and writing.
> 945	1-3	essay not administered	INRW 0016 + INRW 0301	Students who pass INRW 0301 are TSI complete in both reading and writing.

Co-requisite courses: ENGL 1301, ENGL 2311, HUMA 1301

Students who are not TSI complete are only allowed to enroll in one co-requisite course until they are TSI complete.

(This page left blank intentionally)

Course Descriptions

Explanation of Items in Course Descriptions

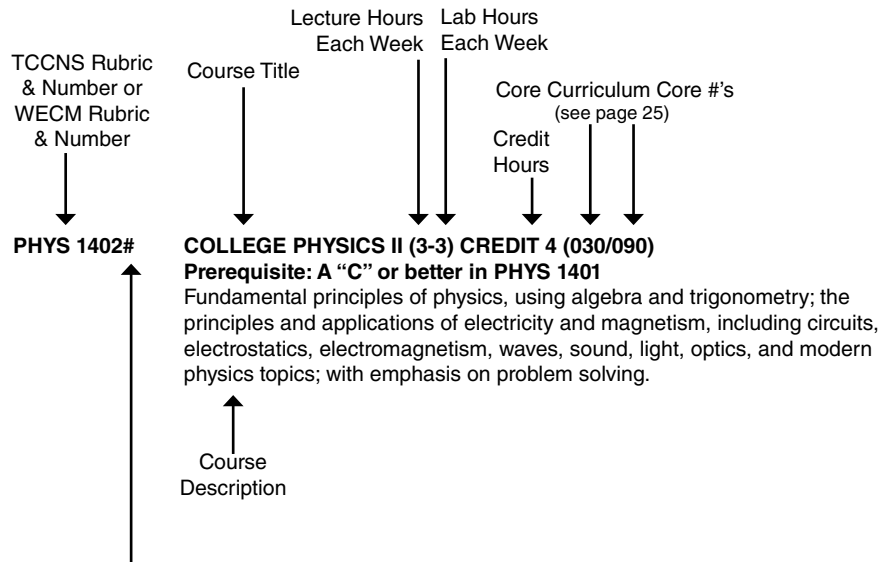

(#) Courses are equivalent to academic courses listed in the current edition of the *Community College General Academic Course Guide Manual*.

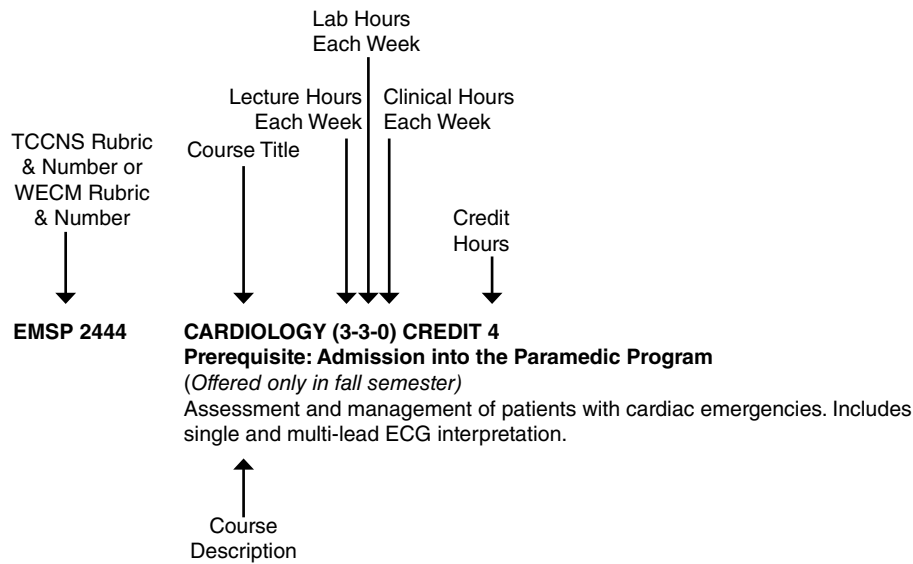

Only courses from the Community College General Academic Course Guide Manual (ACGM) can be used towards the Associate of Arts or Associate of Science degree.

COURSE DESCRIPTIONS

- ACCT 2301# PRINCIPLES OF FINANCIAL ACCOUNTING (2-3) CREDIT 3**
Prerequisite: Meet Texas Success Initiative complete college-readiness standard for Reading and Mathematics or consent of Instructor
Recommended corequisite: MATH 1324 Mathematics for Business & Social Science
 This course is an introduction to the fundamental concepts of financial accounting as prescribed by U.S. generally accepted accounting principles (GAAP) as applied to transactions and events that affect business organizations. Students will examine the procedures and systems to accumulate, analyze, measure, and record financial transactions. Students will use recorded financial information to prepare a balance sheet, income statement, statement of cash flows, and statement of shareholders' equity to communicate the business entity's results of operations and financial position to users of financial information who are external to the company. Students will study the nature of assets, liabilities, and owners' equity while learning to use reported financial information for purposes of making decisions about the company. Students will be exposed to International Financial Reporting Standards (IFRS).
- ACCT 2302# PRINCIPLES OF MANAGERIAL ACCOUNTING (2-3) CREDIT 3**
Prerequisite: A grade of C or better in ACCT 2301 Principles of Financial Accounting
 This course is an introduction to the fundamental concepts of managerial accounting appropriate for all organizations. Students will study information from the entity's accounting system relevant to decisions made by internal managers, as distinguished from information relevant to users who are external to the company. The emphasis is on the identification and assignment of product costs, operational budgeting and planning, cost control, and management decision making. Topics include product costing methodologies, cost behavior, operational and capital budgeting, and performance evaluation.
- ACNT 1303 INTRODUCTION TO ACCOUNTING I (3-1) CREDIT 3**
 A study of analyzing, classifying, and recording business transactions in a manual and computerized environment. Emphasis on understanding the complete accounting cycle and preparing financial statements, bank reconciliations, and payroll.
- ACNT 1311 INTRODUCTION TO COMPUTERIZED ACCOUNTING (2-2) CREDIT 3**
Prerequisite: A grade of C or better in ACNT 1303 or ACCT 2301 or instructor approval
(Offered only in spring semester)
 Introduction to utilizing the computer in maintaining accounting records with primary emphasis on a general ledger package.
- ACNT 1329 PAYROLL AND BUSINESS TAX ACCOUNTING (3-0) CREDIT 3**
Prerequisite: A grade of C or better in ACNT 1303 or ACCT 2301 or instructor's approval
(Offered only in fall semester)
 A study of payroll procedures, taxing entities, and reporting requirements of local, state, and federal taxing authorities in a manual and computerized environment.
- ARTS 1301# ART APPRECIATION (3-0) CREDIT 3 (050/090)**
Prerequisite: Texas Success Initiative complete in Writing and Reading
 A general introduction to the visual arts designed to create an appreciation of the vocabulary, media, techniques, and purposes of the creative process. Students will critically interpret and evaluate works of art within formal, cultural, and historical contexts.
- ARTS 1303# ART HISTORY I (3-0) CREDIT 3 (050/090)**
Prerequisite: Texas Success Initiative complete in Writing and Reading
 A chronological analysis of the historical and cultural contexts of the visual arts from prehistoric times to the 14th century.
- ARTS 1304# ART HISTORY II (3-0) CREDIT 3 (050/090)**
Prerequisite: Texas Success Initiative complete in Writing and Reading
 A chronological analysis of the historical and cultural contexts of the visual arts from the 14th century to the present day.
- ARTS 1311# DESIGN I (2-DIMENSIONAL) (2-4) CREDIT 3**
 An introduction to the fundamental terminology, concepts, theory, and application of two-dimensional design.
- ARTS 1312# DESIGN II (3-DIMENSIONAL) (2-4) CREDIT 3**
 An introduction to the fundamental terminology, concepts, theory, and application of three-dimensional design.
- ARTS 1316# DRAWING I (2-4) CREDIT 3**
 Exploration of ideas using painting media and techniques. Students will explore color theory, painting techniques, and pictorial problems from art historical periods through contemporary styles using oil or acrylic paint.
- ARTS 1317# DRAWING II (2-4) CREDIT 3**
Prerequisite: ARTS 1316 or permission of instructor
 A studio course exploring drawing with continued emphasis on descriptive, expressive, and conceptual approaches. Students will further develop the ability to see and interpret a variety of subjects while using diverse materials and techniques. Course work will facilitate a dialogue in which students will employ critical analysis to broaden their understanding of drawing as a discipline.
- ARTS 2316# PAINTING I (2-4) CREDIT 3**
Prerequisite: Recommended ARTS 1316 Drawing I
 Exploration of ideas using painting media and techniques. Students will explore color theory, painting techniques, and pictorial problems from art historical periods through contemporary styles using oil and acrylic paint.
- ARTS 2346# CERAMICS I (2-4) CREDIT 3**
 A studio art course that introduces basic building, throwing, and other techniques as it relates to the design and production of ceramic sculpture and pottery.

COURSE DESCRIPTIONS

- BCIS 1305# BUSINESS COMPUTER APPLICATIONS (2-4) CREDIT 3 (090)**
(For Business Majors)
Prerequisites: Texas Success Initiative complete or consent of instructor
 Introduces and develops foundational skills in applying essential and emerging business productivity information technology tools. The focus of this course is on business productivity software applications, including word processing, spreadsheets, databases, presentation graphics, data analytics, and business-oriented utilization of the internet. (BCIS 1305 is included in the Business Field of Study.)
- BIOL 0010 BIOLOGICAL FOUNDATIONS NCBO (2-0) CREDIT 0**
Prerequisites: Students assessed as TSI complete in reading and writing
 This Non-Semester-Length/Non-Course Competency-Based Option and Intervention (NCBO) will provide basic information related to biology and chemistry that students should know prior to entering BIOL 2401. Successful completion of this course would allow the student an override on the prerequisite for BIOL 2401.
- BIOL 1322# NUTRITION & DIET THERAPY (3-0) CREDIT 3 (030)**
Prerequisite: Texas Success Initiative complete in Reading, Writing and Mathematics
 This course introduces general nutritional concepts in health and disease and includes practical applications of that knowledge. Special emphasis is given to nutrients and nutritional processes including functions, food sources, digestion, absorption, and metabolism. Food safety, availability, and nutritional information including food labels, advertising, and nationally established guidelines are addressed.
- BIOL 1406# BIOLOGY FOR SCIENCE MAJORS I (3-3) CREDIT 4 (030/090)**
Prerequisite: Texas Success Initiative complete in Reading, Writing, and Math.
Recommended Prerequisite(s): MATH 1314
Successful completion of College Algebra or concurrent enrollment in higher-level mathematics is recommended.
(Offered only in fall semester)
 Fundamental principles of living organisms will be studied, including physical and chemical properties of life, organization, function, evolutionary adaptation, and classification. Concepts of cytology, reproduction, genetics, and scientific reasoning are included. Laboratory activities will reinforce the fundamental principles of living organisms, including physical and chemical properties of life, organization, function, evolutionary adaptation, and classification. Study and examination of the concepts of cytology, reproduction, genetics and scientific reasoning are included.
- BIOL 1407# BIOLOGY FOR SCIENCE MAJORS II (3-3) CREDIT 4 (030/090)**
Prerequisite: Texas Success Initiative complete in Reading, Writing, and Math.
Recommended prerequisite(s): Successful completion of BIOL 1406.
Successful completion of College Algebra or concurrent enrollment in higher-level mathematics.
(Offered only in spring semester)
 The diversity and classification of life will be studied, including animals, plants, protists, fungi, and prokaryotes. Special emphasis will be given to anatomy, physiology, ecology, and evolution of plants and animals. Laboratory activities will reinforce study of the diversity and classification of life, including animals, plants, protists, fungi, and prokaryotes. Special emphasis will be given to anatomy, physiology, ecology, and evolution of plants and animals.
- BIOL 1408# BIOLOGY FOR NON-SCIENCE MAJORS I (3-3) CREDIT 4 (030/090)**
Prerequisite: Texas Success Initiative complete in Reading, Writing and Math.
(Offered only in fall semester)
 Provides a survey of biological principles with an emphasis on humans, including chemistry of life, cells, structure, function, and reproduction. Laboratory activities will reinforce a survey of biological principles with an emphasis on humans, including chemistry of life, cells, structure, function and reproduction.
- BIOL 1409# BIOLOGY FOR NON-SCIENCE MAJORS II (3-3) CREDIT 4 (030/090)**
Prerequisite: Texas Success Initiative complete in Reading, Writing and Math.
(Offered only in spring semester)
 This course will provide a survey of biological principles with an emphasis on humans, including evolution, ecology, plant and animal diversity, and physiology. Laboratory activities will reinforce a survey of biological principles with an emphasis on humans, including evolution, ecology, plant and animal diversity, and physiology.
- BIOL 2306# ENVIRONMENTAL BIOLOGY (3-0) CREDIT 3 (030/090)**
Prerequisite: Texas Success Initiative complete in Reading, Writing and Math.
Recommended prerequisite: MATH 1314 – Successful completion of College Algebra or concurrent enrollment in higher-level mathematics is recommended
 Principles of environmental systems and ecology, including biogeochemical cycles, energy transformations, abiotic interactions, symbiotic relationships, natural resources and their management, lifestyle analysis, evolutionary trends, hazards and risks, and approaches to ecological research.
- BIOL 2401# ANATOMY AND PHYSIOLOGY I (3-3) CREDIT 4**
Prerequisite: Texas Success Initiative complete in Reading and Writing, in addition to one of the following three options: a grade of “C” or better in one semester of college-level biology or chemistry (CHEM 1406 is recommended); co-enrollment in BIOL 2420; or passing BIOL 0010 (Biological Foundations NCBO).
 Anatomy and Physiology I is the first part of a two-course sequence. It is a study of the structure and function of the human body including cells, tissues and organs of the following systems: integumentary, skeletal, muscular, nervous and special senses. Emphasis is on interrelationships among systems and regulation of physiological functions involved in maintaining homeostasis. The lab provides a hands-on learning experience for exploration of human system components and basic physiology. Systems to be studied include integumentary, skeletal, muscular, nervous, and special senses.

COURSE DESCRIPTIONS

- BIOL 2402# ANATOMY AND PHYSIOLOGY II (3-3) CREDIT 4**
Prerequisite: BIOL 2401 with a grade of “C” or better
 Anatomy and Physiology II is the second part of a two-course sequence. It is a study of the structure and function of the human body including the following systems: endocrine, cardiovascular, immune, lymphatic, respiratory, digestive (including nutrition), urinary (including fluid and electrolyte balance), and reproductive (including human development and genetics). Emphasis is on interrelationships among systems and regulation of physiological functions involved in maintaining homeostasis. The lab provides a hands-on learning experience for exploration of human system components and basic physiology. Systems to be studied include endocrine, cardiovascular, immune, lymphatic, respiratory, digestive (including nutrition), urinary (including fluid and electrolyte balance), and reproductive (including human development and genetics).
- BIOL 2404# INTRODUCTORY ANATOMY AND PHYSIOLOGY (3-3) CREDIT 4 (030/090)**
Prerequisite: Texas Success Initiative complete in Reading, Writing and Math.
 Study of the structure and function of human anatomy, including the neuroendocrine, integumentary, musculoskeletal, digestive, urinary, reproductive, respiratory, and circulatory systems. Content may be either integrated or specialized. This course will not substitute for BIOL 2401 or as a prerequisite for BIOL 2402.
- BIOL 2420# MICROBIOLOGY FOR NON-SCIENCE MAJORS (3-3) CREDIT 4 (030/090)**
Prerequisite: Texas Success Initiative complete in Reading, Writing and Math.
 This course covers basic microbiology and immunology and is primarily directed at pre-nursing, pre-allied health, and non-science majors. It provides an introduction to historical concepts of the nature of microorganisms, microbial diversity, the importance of microorganisms and acellular agents in the biosphere, and their roles in human and animal diseases. Major topics include bacterial structure as well as growth, physiology, genetics, and biochemistry of microorganisms. Emphasis is on medical microbiology, infectious diseases, and public health.
- BMGT 1307 TEAM BUILDING (2-2) CREDIT 3**
 Principles of building and sustaining teams in organizations. Includes team dynamics, process improvement, trust and collaboration, conflict resolution, and the role of the individual in the team.
- BMGT 1309# INFORMATION AND PROJECT MANAGEMENT (3-0) CREDIT 3**
(Offered only in fall semester)
 Critical path methods for planning and controlling projects. Includes time/cost trade-offs, resource utilization, stochastic considerations, task determination, time management, scheduling management, status reports, budget management, customer service, professional attitude, and project supervision.
- BMGT 1327 PRINCIPLES OF MANAGEMENT (3-0) CREDIT 3**
 Concepts, terminology, principles, theories, and issues in the field of management.
- BMGT 1341 BUSINESS ETHICS (3-0) CREDIT 3**
Prerequisite: 15 Semester Credit Hours of college work. Texas Success Initiative complete in Reading and Writing.
 Discussion of ethical issues, the development of a moral frame of reference, and the need for an awareness of social responsibility in management practices and business activities. Includes ethical corporate responsibility.
- BMGT 2303 PROBLEM SOLVING AND DECISION MAKING (3-0) (2-2) CREDIT 3**
Prerequisite: Texas Success Initiative complete; Division Approval
(Offered only in spring semester)
 Decision-making and problem-solving processes in organizations utilizing logical and creative problem-solving techniques. Application of theory is provided by experiential activities using managerial decision tools. (This is the capstone course for the Business Management AAS.)
- BUSG 1303# PRINCIPLES OF FINANCE (3-0) CREDIT 3**
BUSG 1303 Prerequisite: Texas Success Initiative complete in Reading and Math.
(Offered only in spring semester)
 Financial dynamics of a business. Includes monetary and credit theory, cash inventory, capital management, and consumer and government finance. Emphasizes the time value of money.
- BUSG 1307 ENTREPRENEURSHIP AND ECONOMIC DEVELOPMENT (3-0) CREDIT 3**
(Offered only in spring semester)
Prerequisite: A “C” or better in ACCT 2301 or ACCT 2302, BMGT 1327 and BUSI 1301.
 Overview of entrepreneurship as an economic development strategy. Includes community support systems for entrepreneurs.
- BUSI 1301# BUSINESS PRINCIPLES (3-0) CREDIT 3**
Prerequisite: Texas Success Initiative complete in Reading & Writing
 This course provides a survey of economic systems, forms of business ownership, and considerations for running a business. Students will learn various aspects of business, management, and leadership functions; organizational considerations; and decision-making processes. Financial topics are introduced, including accounting, money and banking, and securities markets. Also included are discussions of business challenges in the legal and regulatory environment, business ethics, social responsibility, and international business. Emphasized is the dynamic role of business in everyday life.

COURSE DESCRIPTIONS

- BUSI 2301# BUSINESS LAW (3-0) CREDIT 3**
Prerequisite: High school coursework in U.S. history and government, or equivalent. Texas Success Initiative complete in Reading.
(Offered only in fall semester)
 The course provides the student with foundational information about the U.S. legal system and dispute resolution, and their impact on business. The major content areas will include general principles of law, the relationship of business and the U.S. Constitution, state and federal legal systems, the relationship between law and ethics, contracts, sales, torts, agency law, intellectual property, and business law in the global context.
- BUSI 2305# BUSINESS STATISTICS (3-0) CREDIT 3**
(Offered only in fall semester)
Prerequisite(s): MATH 1324 or MATH 1314; BCIS 1305/1405
 Descriptive and inferential statistical techniques for business and economic decision-making. Topics include the collection, description, analysis, and summarization of data; probability; discrete and continuous random variables; the binomial and normal distributions; sampling distributions; tests of hypotheses; estimation and confidence intervals; linear regression; and correlation analysis. Statistical software is used to analyze data throughout the course. (BUSI 2305 is included in the Business Field of Study.)
- CETT 1302 ELECTRICITY PRINCIPLES (2-4) CREDIT 3**
 Principles of electricity including proper use of test equipment, A/C and D/C circuits, and component theory and operations.
- CETT 1325 DIGITAL FUNDAMENTALS (2-4) CREDIT 3**
 An entry level course in digital electronics to include numbering systems, logic gates, Boolean algebra, and combinational logic.
- CETT 1329 SOLID STATE DEVICES (2-4) CREDIT 3**
Prerequisite: CETT 1302 or Instructor Approval
 A study of diodes, transistor characteristics and other semiconductor devices, including analysis of static and dynamic characteristics, biasing techniques, and thermal considerations.
- CETT 1349 DIGITAL SYSTEMS (2-4) CREDIT 3**
Prerequisite: CETT 1325 or Instructor Approval
(Offered only in spring semester)
 A course in electronics covering digital systems. Emphasis on application and troubleshooting digital systems.
- CETT 2339 AMPLIFIED ANALYSIS (2-4) CREDIT 3**
Prerequisite: CETT 1329
(Offered only in spring semester)
 Advanced study of electronic amplifier applications.
- CHEM 1406# INTRODUCTORY CHEMISTRY I (3-3) CREDIT 4 (030/090)**
Prerequisite: Texas Success Initiative complete in Reading and Math.
 Survey course introducing chemistry. Topics may include inorganic, organic, biochemistry, food/physiological chemistry, and environmental/consumer chemistry. Designed for allied health students and for students who are not science majors.
- CHEM 1411# GENERAL CHEMISTRY I (3-3) CREDIT 4 (030/090)**
Prerequisite: A grade of "C" or better in MATH 1314 or more advanced college mathematics course plus Texas Success Initiative complete in reading.
(Offered only in fall semester)
 Fundamental principles of chemistry for majors in the sciences, health sciences, and engineering; topics include measurements, fundamental properties of matter, states of matter, chemical reactions, chemical stoichiometry, periodicity of elemental properties, atomic structure, chemical bonding, molecular structure, solutions, properties of gases, and an introduction to thermodynamics and descriptive chemistry. Basic laboratory experiments supporting theoretical principles presented in lecture; introduction of the scientific method, experimental design, data collection and analysis, and preparation of laboratory reports.
- CHEM 1412# GENERAL CHEMISTRY II (3-3) CREDIT 4 (030/090)**
Prerequisite: A grade of C or better in CHEM 1411
(Offered only in spring semester)
 Chemical equilibrium; phase diagrams and spectrometry; acid-base concepts; thermodynamics; kinetics; electrochemistry; nuclear chemistry; an introduction to organic chemistry and descriptive inorganic chemistry. Basic laboratory experiments supporting theoretical principles presented in lecture; introduction of the scientific method, experimental design, chemical instrumentation, data collection and analysis, and preparation of laboratory reports.

COURSE DESCRIPTIONS

- CHEM 2123# ORGANIC CHEMISTRY I LAB (0-3) CREDIT 1**
Prerequisite: A grade of C or better in CHEM 1312 and CHEM 1112, or CHEM 1412 General Chemistry II (Lecture and Laboratory)
Corequisite: CHEM 2323—Organic Chemistry I
(Offered only in fall semester)
 This laboratory-based course accompanies CHEM 2323, Organic Chemistry I. Laboratory activities will reinforce fundamental principles of organic chemistry, including the structure, bonding, properties, and reactivity of organic molecules; and properties and behavior of organic compounds and their derivatives. Emphasis is placed on organic synthesis and mechanisms. Includes study of covalent and ionic bonding, nomenclature, stereochemistry, structure and reactivity, reaction mechanisms, functional groups, and synthesis of simple molecules. Methods for the purification and identification of organic compounds will be examined.
- CHEM 2125# ORGANIC CHEMISTRY II LAB (0-3) CREDIT 1**
Prerequisite: A grade of C or better in CHEM 2123 and 2323
(Offered only in spring semester)
 This laboratory-based course accompanies CHEM 2325, Organic Chemistry II. Laboratory activities reinforce advanced principles of organic chemistry, including the structure, properties, and reactivity of aliphatic and aromatic organic molecules; and properties and behavior of organic compounds and their derivatives. Emphasis is placed on organic synthesis and mechanisms. Includes study of covalent and ionic bonding, nomenclature, stereochemistry, structure and reactivity, reaction mechanisms, functional groups, and synthesis of simple molecules.
- CHEM 2323# ORGANIC CHEMISTRY I LECTURE (3-0) CREDIT 3**
Prerequisite: A grade of C or better in CHEM 1412
(Offered only in fall semester)
 Fundamental principles of organic chemistry will be studied, including the structure, bonding, properties, and reactivity of organic molecules; and properties and behavior of organic compounds and their derivatives. Emphasis is placed on organic synthesis and mechanisms. Includes study of covalent and ionic bonding, nomenclature, stereochemistry, structure and reactivity, reaction mechanisms, functional groups, and synthesis of simple molecules. THIS COURSE IS INTENDED FOR STUDENTS IN SCIENCE OR PRE-PROFESSIONAL PROGRAMS.
- CHEM 2325# ORGANIC CHEMISTRY II LECTURE (3-0) CREDIT 3**
Prerequisite: A grade of C or better in CHEM 2323 and CHEM 2123, or CHEM 2423 Organic Chemistry I (Lecture and Laboratory)
(Offered only in spring semester)
 Advanced principles of organic chemistry will be studied, including the structure, properties, and reactivity of aliphatic and aromatic organic molecules; and properties and behavior of organic compounds and their derivatives. Emphasis is placed on organic synthesis and mechanisms. Includes study of covalent and ionic bonding, nomenclature, stereochemistry, structure and reactivity, reaction mechanisms, functional groups, and synthesis of simple molecules. THIS COURSE IS INTENDED FOR STUDENTS IN SCIENCE OR PRE-PROFESSIONAL PROGRAMS.
- COSC 1301# INTRODUCTION TO COMPUTING (2-2) CREDIT 3 (090)**
Prerequisites: Texas Success Initiative complete or consent of instructor.
 Overview of computer systems-hardware, operating systems, the Internet, and application software including word processing, spreadsheets, presentation graphics, and databases. Current topics such as the effect of computers on society, and the history and use of computers in business, educational, and other interdisciplinary settings are also studied. This course is not intended to count toward a student's major field of study in business or computer science. No credit if BCIS 1305 has been taken.
- COSC 1315# INTRODUCTION TO COMPUTER PROGRAMMING (2-2) CREDIT 3**
Prerequisite: Texas Success Initiative complete in Reading and Math or consent of instructor.
 Introduction to computer programming for solving a variety of problems. This course is intended for non-computer science and non-computer engineering majors. Emphasis on the fundamentals of design, development, testing, implementation, and documentation of computer programs. Includes problem solving with structured techniques and algorithms using pseudo code and/or graphical representations.
- COSC 1436# PROGRAMMING FUNDAMENTALS I (3-3) CREDIT 4**
Prerequisite: Texas Success Initiative complete in Reading and Math or consent of instructor.
(Offered only in spring semester)
 This course introduces the fundamental concepts of structured programming, and provides a comprehensive introduction to programming for computer science and technology majors. Topics include software development methodology, data types, control structures, functions, arrays, and the mechanics of running, testing, and debugging. This course assumes computer literacy. (This course is included in the Field of Study courses for Computer Science.)
- COSC 1437# PROGRAMMING FUNDAMENTALS II (3-3) CREDIT 4**
Prerequisite: A grade of C or better in COSC 1436 OR previous college credit programming language or consent of instructor.
 This course focuses on the object-oriented programming paradigm, emphasizing the definition and use of classes along with fundamentals of object-oriented design. The course includes basic analysis of algorithms, searching and sorting techniques, and an introduction to software engineering processes. Students will apply techniques for testing and debugging software. (This course is included in the Field of Study Curriculum for Computer Science.)

COURSE DESCRIPTIONS

- CRIJ 1301# INTRODUCTION TO CRIMINAL JUSTICE (3-0) CREDIT 3**
Prerequisite: Texas Success Initiative complete in Reading and Writing.
 This course provides a historical and philosophical overview of the American criminal justice system, including the nature, extent, and impact of crime; criminal law; and justice agencies and processes.
- CRIJ 1306# COURT SYSTEMS AND PRACTICES (3-0) CREDIT 3**
Prerequisite: A grade of C or better in CRIJ 1301 or CRIJ 1307
(Offered only in spring semester)
 This course is a study of the court system as it applies to the structures, procedures, practices and sources of law in American courts, using federal and Texas statutes and case law.
- CRIJ 1310# FUNDAMENTALS OF CRIMINAL LAW (3-0) CREDIT 3**
Prerequisite: A grade of C or better in CRIJ 1301 or CRIJ 1307
(Offered only in fall semester)
 This course is the study of criminal law including application of definitions, statutory elements, defenses and penalties using Texas statutes, the Model Penal Code, and case law. The course also analyzes the philosophical and historical development of criminal law and criminal culpability.
- CRIJ 2313# CORRECTIONAL SYSTEMS AND PRACTICES (3-0) Credit 3**
Prerequisite: Texas Success Initiative complete in Reading and Writing.
(Offered only in spring semester)
 This course is a survey of institutional and non-institutional corrections. Emphasis will be placed on the organization and operation of correctional systems; treatment and rehabilitation; populations served; Constitutional issues; and current and future issues.
- CRIJ 2314# CRIMINAL INVESTIGATION (3-0) CREDIT 3**
Prerequisite: Texas Success Initiative complete in Reading and Writing.
(Offered only in fall semester)
 Investigative theory; collection and preservation of evidence; sources of information; interview and interrogation; uses of forensic sciences; case and trial preparation.
- CRIJ 2328# POLICE SYSTEMS AND PRACTICE (3-0) CREDIT 3**
Prerequisite: Texas Success Initiative complete in Reading and Writing.
 This course examines the establishment, role and function of police in a democratic society. It will focus on types of police agencies and their organizational structure, police-community interaction, police ethics, and use of authority.
- DAAC 1317# BASIC COUNSELING SKILLS (3-0) CREDIT 3**
Prerequisite: Texas Success Initiative complete in Reading and Writing.
(Offered only in spring semester)
 An overview and application of the basic counseling skills.
- DFTG 1325 BLUEPRINT READING AND SKETCHING (3-0) CREDIT 3**
(Offered only in fall semester)
 An introduction to reading and interpreting working drawings for fabrication processes and associated trades. Use of sketching techniques to create pictorial and multiple-view drawings.
- DRAM 1310# THEATER APPRECIATION (3-0) CREDIT 3 (050/090)**
Prerequisite: Texas Success Initiative complete in Reading and Writing.
 Survey of theatre including its history, dramatic works, stage techniques, production procedures and relation to other art forms. Participation in productions may be required.
- ECON 2301# PRINCIPLES OF MACROECONOMICS (3-0) CREDIT 3 (080/090)**
Prerequisite: Texas Success Initiative complete in Reading and Math.
 An analysis of the economy as a whole, including measurement and determination of Aggregate Demand and Aggregate Supply, national income, inflation, and unemployment. Other topics include international trade, economic growth, business cycles, and fiscal policy and monetary policy.
- ECON 2302# PRINCIPLES OF MICROECONOMICS (3-0) CREDIT 3 (080/090)**
Prerequisite: Texas Success Initiative complete in Reading and Math.
 Analysis of the behavior of individual economic agents, including consumer behavior and demand, producer behavior and supply, price and output decisions by firms under various market structures, factor markets, market failures, and international trade.
- EDUC 1300# LEARNING FRAMEWORKS (3-0) CREDIT 3 (090)**
 A study of the research and theory in the psychology of learning, cognition, and motivation; factors that impact learning; and application of learning strategies. Theoretical models of strategic learning, cognition, and motivation serve as the conceptual basis for the introduction of college-level student academic strategies. Students use assessment instruments (e.g., learning inventories) to help them identify their own strengths and weaknesses as strategic learners. Students are ultimately expected to integrate and apply the learning skills discussed across their own academic programs and become effective and efficient learners. Students developing these skills should be able to continually draw from the theoretical models they have learned. EDUC 1300 is equivalent to PSYC 1300; credit will not be given for both EDUC 1300 and PSYC 1300. EDUC 1300 may substitute for SDEV 0301.

COURSE DESCRIPTIONS

- EDUC 1301# INTRODUCTION TO THE TEACHING PROFESSIONS (3-0-1) CREDIT 3**
Prerequisite: Texas Success Initiative complete in Reading and Writing.
(Offered only in fall semester)
 An enriched, integrated pre-service course and content experience that provides active recruitment and institutional support of students interested in a teaching career, especially in high need fields. The course provides students with opportunities to participate in early field observations at all levels of P-12 schools with varied and diverse student populations and provides students with support from college and school faculty, preferably in small cohort groups, for the purpose of introduction to and analysis of the culture of schooling and classrooms. Course content should be aligned as applicable with the State Board of Educator Certification Pedagogy and Professional Responsibilities standards; and the course must include a minimum of 16 contact hours of field experience in P-12 classrooms.
- EECT 1303 INTRODUCTION TO TELECOMMUNICATIONS (2-4) CREDIT 3**
Prerequisite: CETT 1329 or Instructor Approval
(Offered only in fall semester)
 An overview of the telecommunications industry. Topics include the history of the telecommunications industry, terminology, rules and regulations, and industry standards and protocols.
- EMSP 1160 CLINICAL, EMERGENCY MEDICAL TECHNOLOGY/TECHNICIAN (0-0-5) CREDIT 1**
Prerequisite: Admission into the EMT Program
Corequisites: EMSP 1501
 A health-related, work-based learning experience that enables the student to apply specialized occupational theory, skills, and concepts. Direct supervision is provided by the clinical professional.
- EMSP 1261 CLINICAL, EMERGENCY MEDICAL TECHNOLOGY/TECHNICIAN (EMT Paramedic) I (0-0-10) CREDIT 2**
Prerequisite: Admission into the Advanced EMT (AEMT)/Paramedic Program
Corequisites: EMSP 1355, 1356, & 1438
(Offered only in summer session)
 A health-related, work-based learning experience that enables the student to apply specialized occupational theory, skills, and concepts. Direct supervision is provided by the clinical professional. At the completion of this course, the student will be able to perform a comprehensive history and physical exam, develop differential diagnoses, establish and/or maintain a patent airway, oxygenate, and ventilate a patient, implement and evaluate a trauma care plan; perform venapuncture for phlebotomy and IV fluid infusion; safely prepare and administer medications, and communicate & document all pertinent information.
- EMSP 1355 TRAUMA MANAGEMENT (2-2-0) CREDIT 3**
Prerequisite: Admission into the Advanced EMT (AEMT)/Paramedic Program
Corequisites: EMSP 1261, 1356 & 1438
(Offered only in summer session)
 Knowledge and skills in the assessment and management of patients with traumatic injuries.
- EMSP 1356 PATIENT ASSESSMENT AND AIRWAY MANAGEMENT (2-2-0) CREDIT 3**
Prerequisite: Admission into the Advanced EMT (AEMT)/Paramedic Program
Corequisites: EMSP 1261, 1355 & 1438
(Offered only in summer session)
 Knowledge and skills required to perform patient assessment, airway management, and artificial ventilation.
- EMSP 1438 INTRODUCTION TO ADVANCED PRACTICE (3-3-0) CREDIT 4**
Prerequisite: Admission into the Advanced EMT (AEMT)/Paramedic Program
Corequisites: EMSP 1261, 1355 & 1356
(Offered only in summer session)
 Fundamental elements associated with emergency medical services to include preparatory practices, pathophysiology, medication administration, and related topics.
- EMSP 1501 EMERGENCY MEDICAL TECHNICIAN (3-8-0) CREDIT 5**
Prerequisite: Admission into the EMT Program.
Corequisites: EMSP 1160
 Preparation for certification as an Emergency Medical Technician (EMT).
- EMSP 2206 EMERGENCY PHARMACOLOGY (2-0-0) CREDIT 2**
Prerequisite: Admission into the AEMT/Paramedic Program
 A study of drug classifications, actions, therapeutic uses, adverse effects, routes of administration, and calculation of dosages.
- EMSP 2243 ASSESSMENT BASED MANAGEMENT (1-3-0) CREDIT 2**
Prerequisite: Admission into the Paramedic Program
Corequisites: EMSP 2305 & 2363
(Offered only in spring semester)
 A summarative experience covering comprehensive, assessment-based patient care management for the paramedic level.

COURSE DESCRIPTIONS

- EMSP 2262 CLINICAL, EMERGENCY MEDICAL TECHNOLOGY/TECHNICIAN (EMT Paramedic) II (0-0-11) CREDIT 2**
Prerequisite: Admission into the Paramedic Program
Corequisites: EMSP 2330, 2434, & 2444
(Offered only in fall and/or spring semester)
 A health-related, work-based learning experience that enables the student to apply specialized occupational theory, skills, and concepts. Direct supervision is provided by the clinical professional.
- EMSP 2305 EMS OPERATIONS (3-0-0) CREDIT 3**
Prerequisite: Admission into the Paramedic Program
Corequisites: EMSP 2243 & 2363
(Offered only in spring semester)
 Knowledge and skills to safely manage multi-casualty incidents and rescue situations; utilize air medical resources; identify hazardous materials and other specialized incidents.
- EMSP 2330 SPECIAL POPULATIONS (2-2-0) CREDIT 3**
Prerequisite: Admission into the Paramedic Program
Corequisites: EMSP 2444, 2434, & 2262
(Offered only in fall semester)
 Knowledge and skills necessary to assess and manage ill or injured patients in diverse populations to include neonatology, pediatrics, geriatrics, and other related topics.
- EMSP 2352 EMERGENCY MEDICAL SERVICES RESEARCH (3-0-0) CREDIT 3**
Prerequisite: Admission into the EMSP Degree Program or permission of the instructor
(Offered only in fall semester)
 Primary and/or secondary research in current and emerging issues in EMS. Basic research principles, scientific inquiry, and interpretation of professional literature are emphasized.
- EMSP 2358 CRITICAL CARE PARAMEDIC (3-1-0) Credit 3**
Prerequisite: Current Texas or NR Paramedic certification
(Offered only in fall semester)
 Prepares healthcare personnel to function as members of a critical care transport team.
- EMSP 2363 (EMSP 2263) CLINICAL-EMERGENCY MEDICAL TECHNOLOGY/TECHNICIAN EMS (0-0-16) CREDIT 3**
Prerequisite: Current AEMT certification or department approval. Current immunizations, background check and drug screen.
Corequisites: EMSP 2305 & 2243
(Offered only in spring semester)
 A health-related, work-based learning experience that enables the student to apply specialized occupational theory, skills, and concepts. Direct supervision is provided by the clinical professional. It involves a capstone-based experience and direct patient/client care with an affiliate EMS Provider and includes the application of cognitive, psychomotor, and affective skills required to reach entry-level competence as a paramedic. On-site clinical instruction, supervision, and evaluation are the responsibility of an assigned affiliate preceptor with frequent communication with college faculty.
- EMSP 2434 MEDICAL EMERGENCIES (3-2-0) CREDIT 4**
Prerequisite: Current certification as an AEMT and admission into the Paramedic program. Completion or concurrent enrollment in EMSP 2206.
Corequisites: EMSP 2444, 2330, & 2262
(Offered only in fall semester)
 Knowledge and skills in the assessment and management of patients with medical emergencies, including medical overview, neurology, gastroenterology, immunology, pulmonology, urology, hematology, endocrinology, toxicology, and other related topics.
- EMSP 2444 CARDIOLOGY (3-3-0) CREDIT 4**
Prerequisite: Current certification as an AEMT and admission into the Paramedic program. Completion or concurrent enrollment in EMSP 2206.
Corequisites: EMSP 2434, 2330, & 2262
(Offered only in fall semester)
 Assessment and management of patients with cardiac emergencies. Includes single and multi-lead ECG interpretation.
- ENGL 1301# COMPOSITION I (3-0) CREDIT 3 (010)**
Prerequisite: Texas Success Initiative complete in Reading and Writing.
 Intensive study of and practice in writing processes, from invention and researching to drafting, revising, and editing, both individually and collaboratively. Emphasis on effective rhetorical choices, including audience, purpose, arrangement, and style. Focus on writing the academic essay as a vehicle for learning, communicating, and critical analysis.
- ENGL 1302# COMPOSITION II (3-0) CREDIT 3 (010)**
Prerequisite: A grade of C or better in ENGL 1301
 Intensive study of and practice in the strategies and techniques for developing research-based expository and persuasive texts. Emphasis on effective and ethical rhetorical inquiry, including primary and secondary research methods; critical reading of verbal, visual, and multimedia texts; systematic evaluation, synthesis, and documentation of information sources; and critical thinking about evidence and conclusions.

COURSE DESCRIPTIONS

- ENGL 2311# TECHNICAL & BUSINESS WRITING (3-0) CREDIT 3 (010)**
Prerequisite: Texas Success Initiative complete in Reading and Writing. Intensive study of and practice in professional settings. Focus on the types of documents necessary to make decisions and take action on the job, such as proposals, reports, instructions, policies and procedures, e-mail messages, letters, and descriptions of products and services. Practice individual and collaborative processes involved in the creation of ethical and efficient documents.
- ENGL 2322# BRITISH LITERATURE I (3-0) CREDIT 3 (040/090)**
Prerequisite: A grade of C or better in ENGL 1301
 A survey of the development of British literature from the Anglo-Saxon period to the eighteenth century. Students will study works of prose, poetry, drama, and fiction in relation to their historical, linguistic, and cultural contexts. Texts will be selected from a diverse group of authors and traditions.
- ENGL 2323# BRITISH LITERATURE II (3-0) CREDIT 3 (040/090)**
Prerequisite: A grade of C or better in ENGL 1301
 A survey of the development of British literature from the Romantic period to the present. Students will study works of prose, poetry, drama, and fiction in relation to their historical and cultural contexts. Texts will be selected from a diverse group of authors and traditions.
- ENGL 2327# AMERICAN LITERATURE I (3-0) CREDIT 3 (040/090)**
Prerequisite: A grade of C or better in ENGL 1301
 A survey of American literature from the period of exploration and settlement through the Civil War. Students will study works of prose, poetry, drama, and fiction in relation to their historical and cultural contexts. Texts will be selected from among a diverse group of authors for what they reflect and reveal about the evolving American experience and character.
- ENGL 2328# AMERICAN LITERATURE II (3-0) CREDIT 3 (040/090)**
Prerequisite: A grade of C or better in ENGL 1301
 A survey of American literature from the Civil War to the present. Students will study works of prose, poetry, drama, and fiction in relation to their historical and cultural contexts. Texts will be selected from among a diverse group of authors for what they reflect and reveal about the evolving American experience and character.
- ENGR 1201# INTRODUCTION TO ENGINEERING (2-0) CREDIT 2**
Prerequisite: Texas Success Initiative complete Reading/ Writing. A grade of C or better in MATH 1314.
 An introduction to the engineering profession with emphasis on technical communication and team-based engineering design.
- ENGR 1304# ENGINEERING GRAPHICS I (2-2) CREDIT 3**
Prerequisite: A grade of C or better in MATH 1314 or concurrent enrollment in MATH 2412 or MATH 2413.
 Introduction to computer-aided drafting using CAD software and sketching to generate two- and three-dimensional drawings based on the conventions of engineering graphical communication; topics include spatial relationships, multi-view projections and sectioning, dimensioning, graphical presentation of data, and fundamentals of computer graphics.
- ENGR 2301# ENGINEERING MECHANICS-STATIC (3-0) CREDIT 3**
Prerequisite: A grade of C or better in PHYS 2425. A grade of C or better or concurrent enrollment in MATH 2414.
Corequisite(s): MATH 2414 (NOTE: MATH 2414 can be taken as a corequisite or a prerequisite)
 Basic theory of engineering mechanics, using calculus, involving the description of forces, moments, and couples acting on stationary engineering structures; equilibrium in two and three dimensions; free-body diagrams; friction; centroids; centers of gravity; and moments of inertia.
- ENGR 2304# PROGRAMMING FOR ENGINEERS (2-2) CREDIT 3**
Prerequisite: A grade of C or better in MATH 1314. Recommended: A grade of C or better in MATH 2413.
Corequisite(s): Recommended: MATH 2414 (NOTE: MATH 2414 can be taken as a corequisite or a prerequisite)
 Programming principles and techniques for matrix and array operations, equation solving, and numeric simulations applied to engineering problems and visualization of engineering information; platforms include spreadsheets, symbolic algebra packages, and engineering analysis software, and laboratory control software.
- ENGR 2305# ELECTRICAL CIRCUITS I (3-0) CREDIT 3**
Prerequisite: A grade of C or better in MATH 2414 and PHYS 2426.
Corequisite(s): MATH 2320 (NOTE: MATH 2320 can be taken as a corequisite or a prerequisite)
 Principles of electrical circuits and systems. Basic circuit elements (resistance, inductance, mutual inductance, capacitance, independent and dependent controlled voltage, and current sources). Topology of electrical networks; Kirchhoff 's laws; node and mesh analysis; DC circuit analysis; operational amplifiers; transient and sinusoidal steady- state analysis; AC circuit analysis; first- and second-order circuits; Laplace transforms; Bode plots; and use of computer simulation software to solve circuit problems.
- ENGR 2332# MECHANICS OF MATERIALS (2-1) CREDIT**
Prerequisite: A grade of C or better in ENGR 2301.
 Stresses, deformations, stress-strain relationships, torsions, beams, shafts, columns, elastic deflections in beams, combined loading, and combined stresses.

COURSE DESCRIPTIONS

- ENVR 1301# ENVIRONMENTAL SCIENCE I (3-0) CREDIT 3 (030/090)**
Prerequisite: Texas Success Initiative complete in Reading.
 A survey of the forces, including humans, that shape our physical and biologic environment, and how they affect life on Earth. Introduction to the science and policy of global and regional environmental issues, including pollution, climate change, and sustainability of land, water, and energy resources. ENVR 1301 is equivalent to GEOL 1305.
- ESLR 0016 ESOL READING AND VOCABULARY (NCBO); (0-1) CREDIT 0**
 This course develops English reading proficiency and vocabulary for academic, career, or personal purposes in speakers of languages other than English and prepares them to function in a multicultural, multilingual society.
- ESLW 0016 ESOL WRITING FOR NON-NATIVE SPEAKERS (NCBO); (0-1) CREDIT 0**
 This course focuses on strategies and techniques of writing and composition. Open only to non-native speakers.
- GEOG 1303# WORLD REGIONAL GEOGRAPHY (3-0) CREDIT 3 (080/090)**
Prerequisite: Texas Success Initiative complete in Reading and Writing.
 This course is an introduction to the world's major regions seen through their defining physical, social, cultural, political, and economic features. These regions are examined in terms of their physical and human characteristics and their interactions. The course emphasizes relations among regions on issues such as trade, economic development, conflict, and the role of regions in the globalization process.
- GEOL 1303# PHYSICAL GEOLOGY (3-0) CREDIT 3 (030/090)**
Prerequisite: Texas Success Initiative complete in Reading.
 Introduction to the study of the materials and processes that have modified and shaped the surface and interior of Earth over time. These processes are described by theories based on experimental data and geologic data gathered from field observations. No credit if GEOL 1403 has been taken.
- GEOL 1305# ENVIRONMENTAL SCIENCE (3-0) CREDIT 3 (030/090)**
Prerequisite: Texas Success Initiative complete in Reading.
 A survey of the forces, including humans, that shape our physical and biologic environment, and how they affect life on Earth. Introduction to the science and policy of global and regional environmental issues, including pollution, climate change, and sustainability of land, water, and energy resources. GEOL 1305 is equivalent to ENVR 1301.
- GEOL 1345# OCEANOGRAPHY (3-0) CREDIT 3 (030/090)**
Prerequisite: Texas Success Initiative complete in Reading.
 Survey of oceanography and related sciences
- GEOL 1347# METEOROLOGY (3-0) CREDIT 3 (030/090)**
Prerequisite: Texas Success Initiative complete in Reading.
 Survey of meteorology and related sciences
- GEOL 1401# EARTH SCIENCE FOR NON-SCIENCE MAJORS I (3-3) CREDIT 4 (030/090)**
Prerequisite: Texas Success Initiative complete in Reading.
 Lecture: Introduction to the study of the materials and processes that have modified and shaped the surface and interior of Earth over time. These processes are described by theories based on experimental data and geologic data gathered from field observations. Lab: This laboratory-based course accompanies GEOL 1301, Earth Sciences I. Activities will cover methods used to collect and analyze data in geology, meteorology, oceanography, and astronomy.
- GEOL 1402# EARTH SCIENCE FOR NON-SCIENCE MAJORS II (3-3) CREDIT 4 (030/090)**
Prerequisite: Texas Success Initiative complete in Reading.
 Lecture: Extension of the study of geology, astronomy, meteorology, oceanography, focusing on natural resources, hazards and climate variability. Lab: This laboratory-based course accompanies GEOL 1302, Earth Sciences II. Activities will focus on methods used to collect and analyze data related to natural resources, hazards and climate variability.
- GEOL 1403# PHYSICAL GEOLOGY (3-3) CREDIT 4 (030/090)**
Prerequisite: Texas Success Initiative complete in Reading.
 Lecture: Introduction to the study of the materials and processes that have modified and shaped the surface and interior of Earth over time. These processes are described by theories based on experimental data and geologic data gathered from field observations. Lab: Laboratory activities will cover methods used to collect and analyze earth science data.
- GEOL 1404# HISTORICAL GEOLOGY (3-3) CREDIT 4 (030/090)**
Prerequisite: GEOL 1303 or 1403 Physical Geology
Texas Success Initiative complete in Reading.
 Lecture: A comprehensive survey of the history of life and major events in the physical development of Earth as interpreted from rocks and fossils. Lab: Laboratory activities will introduce methods used by scientists to interpret the history of life and major events in the physical development of Earth from rocks and fossils.

COURSE DESCRIPTIONS

- GOVT 2305# FEDERAL GOVERNMENT (3-0) CREDIT 3 (070)**
(Federal Constitution & Topics)
Prerequisite: Texas Success Initiative complete in Reading and Writing.
Corequisite: None or co-enrolled in an appropriate developmental course or Non-Course Based Option (NCBO) for students who are not TSI complete.
 Origin and development of the U.S. Constitution, structure and powers of the national government including the legislative, executive, and judicial branches, federalism, political participation, the national election process, public policy, civil liberties, and civil rights.
- GOVT 2306# TEXAS GOVERNMENT (3-0) CREDIT 3 (070)**
(Texas Constitution & Topics)
Prerequisite: Texas Success Initiative complete in Reading and Writing.
Corequisite: None or co-enrolled in an appropriate developmental course or Non-Course Based Option (NCBO) for students who are not TSI complete.
 Origin and development of the Texas constitution, structure and powers of state and local government, federalism and inter-governmental relations, political participation, the election process, public policy, and the political culture of Texas.
- HIST 1301# UNITED STATES HISTORY I (3-0) CREDIT 3 (060/090)**
Prerequisite: Texas Success Initiative complete in Reading and Writing.
Corequisite: None or co-enrolled in an appropriate developmental course or Non-Course Based Option (NCBO) for students who are not TSI complete.
 A survey of the social, political, economic, cultural, and intellectual history of the United States from the pre-Columbian era to the Civil War/Reconstruction period. United States History I includes the study of pre-Columbian, colonial, revolutionary, early national, slavery and sectionalism, and the Civil War/Reconstruction eras. Themes that may be addressed in United States History I include: American settlement and diversity, American culture, religion, civil and human rights, technological change, economic change, immigration and migration, and creation of the federal government.
- HIST 1302# UNITED STATES HISTORY II (3-0) CREDIT 3 (060/090)**
Prerequisite: Texas Success Initiative complete in Reading and Writing.
Corequisite: None or co-enrolled in an appropriate developmental course or Non-Course Based Option (NCBO) for students who are not TSI complete.
 A survey of the social, political, economic, cultural, and intellectual history of the United States from the Civil War/Reconstruction era to the present. United States History II examines industrialization, immigration, world wars, the Great Depression, Cold War and post-Cold War eras. Themes that may be addressed in United States History II include: American culture, religion, civil and human rights, technological change, economic change, immigration and migration, urbanization and suburbanization, the expansion of the federal government, and the study of U.S. foreign policy.
- HIST 2301# TEXAS HISTORY (3-0) CREDIT 3 (060/090)**
Prerequisite: Texas Success Initiative complete in Reading and Writing.
Corequisite: None or co-enrolled in an appropriate developmental course or Non-Course Based Option (NCBO) for students who are not TSI complete.
 A survey of the political, social, economic, cultural, and intellectual history of Texas from the pre-Columbian era to the present. Themes that may be addressed in Texas History include: Spanish colonization and Spanish Texas; Mexican Texas; the Republic of Texas; statehood and secession; oil, industrialization, and urbanization; civil rights; and modern Texas.
- HIST 2327# MEXICAN AMERICAN HISTORY I (to the United States-Mexico War Era) (3-0) CREDIT 3 (090)**
Prerequisite: Texas Success Initiative complete in Reading and Writing.
Corequisite: None or co-enrolled in an appropriate developmental course or Non-Course Based Option (NCBO) for students who are not TSI complete.
 A survey of the economic, social, political, intellectual, and cultural history of Mexican Americans/Chicanx. Periods include early indigenous societies, conflict and conquest, early European colonization and empires, New Spain, early revolutionary period, Mexican independence and nation building, United States expansion to the United States-Mexico War Era. Themes to be addressed are mestizaje and racial formation in the early empire, rise and fall of native and African slavery, relationship to early global economies, development of New Spain's/Mexico's northern frontier, gender and power, missions, resistance and rebellion, emergence of Mexican identities, California mission secularization, Texas independence, United States' wars with Mexico, and the making of borders and borderlands. (May be applied to U.S. History requirement.)
- HIST 2328# MEXICAN AMERICAN HISTORY II (from the United States-Mexico War era) (3-0) CREDIT 3 (090)**
Prerequisite: Texas Success Initiative complete in Reading and Writing.
Corequisite: None or co-enrolled in an appropriate developmental course or Non-Course Based Option (NCBO) for students who are not TSI complete.
 A survey of the economic, social, political, intellectual, and cultural history of Mexican Americans/Chicanx. Periods include the United States-Mexico War Era, incorporation of Northern Mexico into the United States, Porfirian Mexico, and the nineteenth century American West, 1910 Mexican Revolution and Progressive Era, the Great Depression and New Deal, World War II and the Cold War, Civil Rights Era, Conservative Ascendancy, the age of NAFTA and turn of the 21st Century developments. Themes to be addressed are the making of borders and borderlands, impact of Treaty of Guadalupe Hidalgo, gender and power, migration and national identities, citizenship and expulsion, nineteenth century activism and displacement, industrialization and the making of a transnational Mexican working class, urbanization and community formation, emergence of a Mexican American Generation, war and citizenship, organized advocacy and activism, Chicano Movement, changing identifications and identities, trade and terrorism. (May be applied to U.S. History requirement.)

COURSE DESCRIPTIONS

- HPRS 2300 PHARMACOLOGY FOR HEALTH PROFESSIONS (3-0) CREDIT 3**
Prerequisite: Texas Success Initiative complete in Reading, Writing and Math.
 A study of drug classifications, actions, therapeutic uses, adverse effects, routes of administration, client education, and calculation of dosages. Introduction into the principles of pharmacology with an explanation of ethnic, cultural, and age considerations in drug therapy. The three systems most commonly used to calculate drug dosages will be reviewed. Conversion from one system to another will be illustrated. Emphasis will be on accuracy in calculating dosages. Prototype drugs will be used to illustrate each drug category with emphasis on nursing implications.
- HUMA 1301# INTRODUCTION TO HUMANITIES I (3-0) CREDIT 3**
TSI Complete in Reading and Writing or enrolled in an appropriate developmental course or Non-Course Based Option (NCBO)
Corequisite(s): None or co-enrolled in an appropriate developmental course or Non-Course Based Option (NCBO) for students who are not TSI complete
 This stand-alone course is an interdisciplinary survey of cultures focusing on the philosophical and aesthetic factors in human values with an emphasis on the historical development of the individual and society and the need to create.
- INRW 0016 INTEGRATED READING AND WRITING (BASE NCBO) (0-1) CREDIT 0**
Corequisite: INRW 0301
 Integration of critical reading and academic writing skills. This Intervention is designed specifically for students assessed at BASE levels 3-4 and must be part of a student's co-enrollment: -as a mainstreamed intensifier providing contact hour or additional, just-in-time instructional support for the student's success in the developmental IRW course, or - as a contextualized and/or integrated basic skills instructional support for a Career/Technical Education course.
- INRW 0017 INTEGRATED READING AND WRITING (EXIT NCBO) (0-1) CREDIT 0**
Corequisite(s): One of the following courses: ENGL 1301, ENGL 2311, or HUMA 1301
 Integration of critical reading and academic writing skills. Successful completion of this intervention if taught at the upper (exit) level fulfills TSI requirements for reading and/or writing. note: For institutions offering one or more levels, this NCBO shall be used for upper (exit) level and may be used for lower level(s).
- INRW 0301 INTEGRATED READING AND WRITING (3-0) CREDIT 0**
Corequisite(s): One of the following courses: ENGL 1301, ENGL 2311, or HUMA 1301
 INRW 0301 is the integration of critical reading and academic writing skills. This course is designed to advance students' critical reading and academic writing skills. The focus of the course will be on applying critical reading skills for organizing, analyzing, and retaining material and developing written work appropriate to the audience, purpose, situation, and length of the assignment. The course combines basic academic reading skills with basic writing skills to increase students' proficiency in composing a variety of academic texts. Successful completion of this course, and its co-requisite course, fulfills all TSI reading and writing requirements.
- INTC 1301 PRINCIPLES OF INDUSTRIAL MEASUREMENTS I (2-4) CREDIT 3**
(Offered only in spring semester)
 Principles of measurement. Includes operation of devices used to measure process variables and basic control functions.
- INTC 1343 APPLICATION OF INDUSTRIAL AUTOMATIC CONTROL (2-4) CREDIT 3**
Prerequisite/Corequisite: INTC 1301 or Instructor Approval
(Offered only in fall semester)
 Automatic process control including measuring devices, analog and digital instrumentation, signal transmitters, recorders, alarms, controllers, control valves, and process and instrument diagrams. Includes connection and troubleshooting of loops.
- INTC 1350 DIGITAL MEASUREMENT AND CONTROL (2-4) CREDIT 3**
Prerequisite: CETT 1349 or Instructor Approval
(Offered only in fall semester)
 Basic measurement control instrumentation. Includes movement of digital data through common systems employing parallel and serial transfers.
- INTC 1355 UNIT OPERATIONS (2-4) CREDIT 3**
Prerequisite/Corequisite: INTC 1301 or Instructor Approval
(Offered only in spring semester)
 Automatic control requirements of industrial processes. Includes control systems, control loop tuning, and analysis.
- INTC 1356 INSTRUMENTATION CALIBRATION (2-4) CREDIT 3**
Prerequisite/Corequisite: INTC 1301 or Instructor Approval
(Offered only in fall semester)
 Techniques for configuring and calibrating transmitters, controllers, recorders, valves, and valve positioners.
- INTC 1357 AC/DC MOTOR CONTROL (2-2) CREDIT 3**
Prerequisite: CETT 1302 or Instructor Approval
(Offered only in fall semester)
 A study of electric motors and motor control devices common to a modern industrial environment. A presentation of motor characteristics with emphasis on starting, speed control, and stopping systems.

COURSE DESCRIPTIONS

- INTC 2330 INSTRUMENTATION SYSTEMS TROUBLESHOOTING (2-2) CREDIT 3**
Prerequisite: INTC 1343 or Instructor Approval
(Offered only in spring semester)
 Techniques for troubleshooting instrumentation systems in a process environment. Includes troubleshooting upsets in processes.
- INTC 2336 DISTRIBUTED CONTROL AND PROGRAMMABLE LOGIC (2-4) CREDIT 3**
Prerequisite: INTC 1343 or Instructor Approval
(Offered only in spring semester)
 An overview of distributed control systems including configuration of programmable logic controllers, smart transmitters, and field communicators. Functions of digital systems in a process control environment.
- INTC 2680 COOPERATIVE EDUCATION – INSTRUMENTATION TECHNOLOGY/TECHNICIAN (1-39) CREDIT 6**
Prerequisite: AAS in Instrumentation or Instructor Approval
 Career-related activities encountered in the student's area of specialization offered through an individualized agreement among the college, employer, and student. Under the supervision of the college and employer, the student combines classroom learning with work experience. Includes a lecture component.
- ITCC 1314 CCNA 1: INTRODUCTION TO NETWORKS (2-3) CREDIT 3**
(Offered only in fall semester)
 This course covers networking architecture, structure, and functions; introduces the principles and structure of IP addressing and the fundamentals of Ethernet concepts, media, and operations to provide a foundation for the curriculum.
- ITCC 1344 CCNA2: SWITCHING, ROUTING, AND WIRELESS NETWORKS (2-4) CREDIT 3**
Prerequisite: ITCC 1314
 Describes the architecture, components, and operations of routers and switches in small networks and introduces wireless local area networks (WLAN) and security concepts; provides an in-depth understanding of how routers and switches operate and are implemented in the LAN environment.
- ITCC 2320 CCNA3: ENTERPRISE NETWORKING, SECURITY & AUTOMATION (2-4) CREDIT 3**
Prerequisite: ITCC 1344
 Describes the architecture, components, operations, and security to scale for large, complex networks, including wide area network (WAN) technologies. Emphasizes network security concepts and introduces network virtualization and automation.
- ITNW 1309 FUNDAMENTALS OF CLOUD COMPUTING (2-3) CREDIT 3**
(Offered only in fall semester)
 Introduction to Cloud computing from a business and technical perspective, including Cloud concepts, services, architecture, system integration, connectivity, data center migration, administration, security, compliance and technical support. Coverage includes preparation for industry certifications. Topics may adapt to changes in industry practices.
- ITNW 1336 CLOUD DEPLOYMENT AND INFRASTRUCTURE MANAGEMENT (2-4) CREDIT 3**
Prerequisite: ITNW 1309
(Offered only in spring semester)
 Focus on Cloud infrastructure, deployment, security models, and key considerations in migrating to Cloud computing. Includes the technologies and processes required to build on-premise and Cloud environments, including computation, storage, networking, virtualization, business continuity, security, and management.
- ITNW 1354 IMPLEMENTING AND SUPPORTING SERVERS (2-2) CREDIT 3**
Prerequisite: ITNW 2305
(Offered only in fall semester)
 Implement, administer, and troubleshoot information systems that incorporate servers in a networked computing environment.
- ITNW 2305 NETWORK ADMINISTRATION (MICROSOFT) (2-2) CREDIT 3**
(Offered only in spring semester)
 Topics include network components, user accounts and groups, network file systems, file systems security, and network printing.
- ITNW 2335 NETWORK TROUBLESHOOTING AND SUPPORT (2-4) CREDIT 3**
Prerequisite: A C or better in ITCC 2320, ITNW 1336, and ITNW 1354 or concurrent enrollment.
(Offered only in spring semester)
 Troubleshoot and support networks with emphasis on solving real world problems in a hands-on environment. Topics include troubleshooting and research techniques, available resources, and network management hard/software.
- ITSC 1309 INTEGRATED SOFTWARE APPLICATIONS I (2-2) CREDIT 3**
 Introduction to business productivity software suites using word processing, spreadsheets, databases, and/or presentation software.
- ITSC 1316 LINUX INSTALLATION AND CONFIGURATION (2-2) CREDIT 3**
(Offered only in spring semester)
 Introduction to Linux operating system. Includes Linux installation, basic administration, utilities and commands, upgrading, networking, security, and application installation. Emphasizes hands-on setup, administration, and management of Linux.

COURSE DESCRIPTIONS

- ITSC 1325 PERSONAL COMPUTER HARDWARE & OS (A+) (2-3) CREDIT 3**
(Offered only in fall semester)
 Current personal computer hardware including assembly, upgrading, setup, configuration, and troubleshooting. Also an introduction to personal computer operating systems including installation, configuration, file management, memory and storage management, control of peripheral devices, and use of utilities. A student may receive credit for this course by passing the CompTIA A+ exams.
- ITSC 2339 PERSONAL COMPUTER HELP DESK SUPPORT (2-2) CREDIT 3**
(Offered only in fall semester)
 Diagnosis and solution of user hardware and software related problems with on-the-job and/or simulated projects.
- ITSE 1359 INTRODUCTION TO SCRIPTING LANGUAGES (2-3) CREDIT 3**
Recommended Prerequisite: ITNW 2305
(Offered only in fall semester)
 Introduction to scripting languages including basic data types, control structures, regular expressions, input/output, and textual analysis. Topics may adapt to changes in industry practices.
- ITSW1307 INTRODUCTION TO DATABASE (MYSQL) (2-3) CREDIT 3**
 Introduction to relational and non-relational database theory and the practical applications of a contemporary databases. Topics may adapt to changes in industry practices.
- ITSY 1342 INFORMATION TECHNOLOGY SECURITY (2-2) CREDIT 3**
(Offered only in fall semester)
 Instruction in security for network computer hardware, software, virtualization, and data, including physical security; backup procedures; relevant tools; encryption; and protection from viruses. Topics may adapt to changes in industry practices.
- ITSY 2345 NETWORK DEFENSE AND COUNTERMEASURES (2-4) CREDIT 3**
Prerequisite(s): ITSY 1342
(Offered only in spring semester)
 This is a practical application and comprehensive course that includes the planning, design, and construction of a complex network that will sustain an attack, document events, and mitigate the effects of an attack.
- MATH 0003 NCBO FOR MATH 0303 (INTERMEDIATE ALGEBRA) (0-1) CREDIT 0**
Prerequisite: A score of ABE 5 or 6 on the mathematics portion of the TSI Assessment 1.0, or successful completion of MATH 0300, but not yet TSI complete.
Corequisite(s): MATH 0303
 This Non-Semester-Length/Non-Course Competency-Based Option and Intervention (NCBO) will provide support for STEM-path students needing MATH 0303 (Intermediate Algebra). MATH 0003 is delivered in a face-to-face format with directed review, just-in-time instruction, and an emphasis on math-specific study skills. This NCBO will not transfer and will not be used to meet degree requirements.
- MATH 0014 NCBO FOR COLLEGE ALGEBRA (MATH 1314) (0-2) CREDIT 0**
Prerequisite: Above a score of 342 on the mathematics section of the TSI Assessment 1.0 or below a score of 950 on TSI Assessment 2.0 with a diagnostic score of 5 and proficient in Algebraic and/or Quantitative, or ALEKS PPL score of 40-45, but not TSI complete (for the algebraic path) as defined by the Texas Higher Education Coordinating Board (THECB). Students below these scores must visit with their advisor for course options.
Corequisite(s): MATH 1314
 This Non-Semester-Length/Non-Course Competency-Based Option and Intervention (NCBO) will provide support for the STEM pathway credit-level course MATH 1314. MATH 0014 is delivered in a face-to-face format with directed review, just-in-time instruction, and an emphasis on math-specific study skills. This NCBO will not transfer and will not be used to meet degree requirements.
- MATH 0016 P.A.S.S. PREP FOR ACADEMIC STUDENT SUCCESS (0-1) CREDIT 0**
 This Non-Semester-Length/Non-Course Competency-Based Option and Intervention (NCBO) is designed to improve upon students' math skills in order to help provide a greater opportunity for success on the math portion of the placement exam. Topics range from basic arithmetic through algebra; including, but not limited to, operations on numbers, linear equations, factoring, quadratics, rational expression, radicals, and appropriate applications.
- MATH 0024 NCBO FOR MATHEMATICS FOR BUSINESS & SOCIAL SCIENCES (MATH 1324) (0-2) CREDIT 0**
Prerequisite: Above a score of 342 on the mathematics section of the TSI Assessment 1.0, below a score of 950 on TSI Assessment 2.0 with a diagnostic score of 5, or ALEKS PPL score of 30-45, but not TSI complete (for the algebraic path) as defined by the Texas Higher Education Coordinating Board (THECB), or successful completion of MATH 0401. Students below these scores must visit with their advisor for course options.
Corequisite(s): MATH 1324
 This Non-Semester-Length/Non-Course Competency-Based Option and Intervention (NCBO) will provide just-in-time support for the STEM pathway credit-level course MATH 1324. MATH 0024 is delivered in a face-to-face format with directed review, just-in-time instruction, and an emphasis on math-specific study skills. This NCBO will not transfer and will not be used to meet degree requirements.

COURSE DESCRIPTIONS

- MATH 0032 NCBO FOR CONTEMPORARY MATHEMATICS (MATH 1332) (0-2) CREDIT 0**
Prerequisite: A score of ABE 5 or 6 on the mathematics portion of the TSI Assessment 1.0, or a score of 336-349 on the mathematics portion of the TSI Assessment 1.0, or successful completion of MATH 0300, or below a score of 950 on TSI Assessment 2.0 with a diagnostic score of 3, 4, or 5, or ALEKS PPL score of 14-45, but not TSI complete as defined by the Texas Higher Education Coordinating Board (THECB). Students below these scores must visit with their advisor for course options.
Corequisite(s): MATH 1332
 This Non-Semester-Length/Non-Course Competency-Based Option and Intervention (NCBO) will provide support for the non-STEM pathway credit-level course MATH 1332. MATH 0032 is delivered in a face-to-face format with directed review, just-in-time instruction, and an emphasis on math-specific study skills. This NCBO will not transfer and will not be used to meet degree requirements.
- MATH 0042 NCBO FOR ELEMENTARY STATISTICAL METHODS (MATH 1342) (0-2) CREDIT 0**
Prerequisite: A score of ABE 5 or 6 on the mathematics portion of the TSI Assessment 1.0, or a score of 336-349 on the mathematics portion of the TSI Assessment 1.0, or successful completion of MATH 0300, or below a score of 950 on TSI Assessment 2.0 with a diagnostic score of 3, 4, or 5, or ALEKS PPL score of 14-45, but not TSI complete as defined by the Texas Higher Education Coordinating Board (THECB). Students below these scores must visit with their advisor for course options.
Corequisite(s): MATH 1332
 This Non-Semester-Length/Non-Course Competency-Based Option and Intervention (NCBO) will provide support for the non-STEM pathway credit-level course MATH 1342. MATH 0042 is delivered in a face-to-face format with directed review, just-in-time instruction, and an emphasis on math-specific study skills. This NCBO will not transfer and will not be used to meet degree requirements.
- MATH 0300 BASIC MATHEMATICS (3-0) CREDIT 0**
 The course supports students in developing skills, strategies, and reasoning needed to succeed in mathematics, including communication and appropriate use of technology. Topics include the study of numeracy and the real number system; algebraic concepts, notation, and reasoning; quantitative relationships; mathematical models; and problem solving. This course carries institutional credit but will not transfer and will not be used to meet degree requirements
- MATH 0303 INTERMEDIATE ALGEBRA (3-1) CREDIT 0**
Prerequisite: Successful completion of MATH 0301 or MATH 0302 or MATH 0401 or MATH 0402 or a score above ABE 1-4, but below TSI Complete on the mathematics proportion of the TSI Assessment 1.0 or below a score of 950 on TSI Assessment 2.0 with a diagnostic score of 5 but not TSI complete (for the algebraic path) as defined by the Texas Higher Education Coordinating Board (THECB). Students below these scores must visit with their advisor for course options.
Corequisite: None or co-enrolled in an appropriate developmental course or Non-Course Based Option (NCBO) for students who are not TSI complete.
 A study of relations and functions, inequalities, algebraic expressions and equations (absolute value, polynomial, radical, rational), with a special emphasis on linear and quadratic expressions and equations. This course carries institutional credit but will not transfer and will not be used to meet degree requirements.
- MATH 0314 DEVELOPMENTAL COREQUISITE CLASS FOR MATH 1314 (3-0) CREDIT 0**
Prerequisite: A score of ABE 5 or 6 on the mathematics portion of the TSI Assessment 1.0, or a score of 336-349 on the mathematics portion of the TSI Assessment 1.0, or below a score of 950 on TSI Assessment 2.0 with a diagnostic score of 5, or ALEKS PPL score of 30-39, or successful completion of MATH 0401, but not TSI complete (for the Algebraic path) as defined by the Texas Higher Education Coordinating Board (THECB). Students below these scores must visit with their advisor for course options.
Corequisite(s): MATH 1314
 A study of relations and functions, inequalities, algebraic expressions and equations (absolute value, polynomial, radical, rational), with a special emphasis on linear and quadratic expressions and equations. This course carries institutional credit but will not transfer and will not be used to meet degree requirements. Successful completion of this course does not make students TSI complete.
- MATH 0401 ELEMENTARY ALGEBRA (4-0) CREDIT 0**
Prerequisite: Successful completion of MATH 0300, or ALEKS PPL score of 14-29, or below a score of 950 on TSI Assessment 2.0 with a diagnostic score of 3 or 4 but not TSI complete as defined by the Texas Higher Education Coordinating Board (THECB). Students below these scores must visit with their advisor for course options.
 A study of the real number system and arithmetic skills, fundamental algebraic skills, simplifying, solving linear equations and inequalities, graphing in two variables, exponents and polynomials, factoring polynomials, and reasoning skills. This course carries institutional credit but will not transfer and will not be used to meet degree requirement.
- MATH 1314# COLLEGE ALGEBRA (3-1) CREDIT 3 (020/090)**
Prerequisite: Meet TSI college-readiness standard for mathematics (a score of 350 or higher on the TSI Assessment 1.0, a score of 950 or higher on the TSI Assessment 2.0, a score below 950 with a diagnostic score of 6 on the TSI Assessment 2.0, or a grade of SC or better in MATH 0303) or ALEKS PPL score of 46 or higher.
Corequisite: None or co-enrolled in an appropriate developmental course or Non-Course Based Option (NCBO) for students who are not TSI complete.
 In-depth study and applications of polynomial, rational, radical, exponential and logarithmic functions, and systems of equations using matrices. Additional topics such as sequences, series, probability, and conics may be included.

COURSE DESCRIPTIONS

- MATH 1316# PLANE TRIGONOMETRY (3-0) CREDIT 3 (020/090)**
Prerequisite: Meet TSI college-readiness standard for mathematics (a score of 350 or higher on the TSI Assessment 1.0, a score of 950 or higher on the TSI Assessment 2.0, a score below 950 with a diagnostic score of 6 on the TSI Assessment 2.0, or a grade of SC or better in MATH 0303) or ALEKS PPL score of 46 or higher.
 In-depth study and applications of trigonometry including definitions, identities, inverse functions, solutions of equations, graphing, and solving triangles. Additional topics such as vectors, polar coordinates and parametric equations may be included.
- MATH 1324# MATHEMATICS FOR BUSINESS & SOCIAL SCIENCES (finite mathematics) (3-0) CREDIT 3 (020/090)**
Prerequisite: : Meet TSI college-readiness standard for mathematics (a score of 350 or higher on the TSI Assessment 1.0, a score of 950 or higher on the TSI Assessment 2.0, a score below 950 with a diagnostic score of 6 on the TSI Assessment 2.0, or a grade of SC or better in MATH 0303) or ALEKS PPL score of 46 or higher. Must also meet TSI college-readiness standard for reading.
Corequisite: None or co-enrolled in an appropriate developmental course or Non-Course Based Option (NCBO) for students who are not TSI complete
 The application of common algebraic functions, including polynomial, exponential, logarithmic, and rational, to problems in business, economics, and the social sciences are addressed. The applications include mathematics of finance, including simple and compound interest and annuities; systems of linear equations; matrices; linear programming; and probability, including expected value.
- MATH 1325# CALCULUS FOR BUSINESS & SOCIAL SCIENCES (3-0) CREDIT 3 (090)**
Prerequisite: A grade of C or better in MATH 1314 or MATH 1324 or ALEKS PPL score of 61 or higher.
 This course is the basic study of limits and continuity, differentiation, optimization and graphing, and integration of elementary functions, with emphasis on applications in business, economics, and social sciences. This course is not a substitute for MATH 2413, Calculus I.
- MATH 1332# CONTEMPORARY MATHEMATICS (Quantitative Reasoning) (3-0) CREDIT 3 (020/090)**
Prerequisite: Meet TSI college-readiness standard for mathematics (a score of 350 or higher on the TSI Assessment 1.0, a score of 950 or higher on the TSI Assessment 2.0, a score below 950 with a diagnostic score of 6 on the TSI Assessment 2.0, or a grade of SC or better in MATH 0303) or ALEKS PPL score of 46 or higher.
Corequisite: None or co-enrolled in an appropriate developmental course or Non-Course Based Option (NCBO) for students who are not TSI complete
 Topics may include introductory treatments of sets, logic, number systems, number theory, relations, functions, probability and statistics. Appropriate applications are included.
- MATH 1342# ELEMENTARY STATISTICAL METHODS (3-0) CREDIT 3 (020/090)**
Prerequisite: Meet TSI college-readiness standard for mathematics (a score of 350 or higher on the TSI Assessment 1.0, a score of 950 or higher on the TSI Assessment 2.0, a score below 950 with a diagnostic score of 6 on the TSI Assessment 2.0, or a grade of SC or better in MATH 0303) or ALEKS PPL score of 46 or higher. Must also meet TSI college-readiness standard for reading.
Corequisite: None or co-enrolled in an appropriate developmental course or Non-Course Based Option (NCBO) for students who are not TSI complete
 Collection, analysis, presentation and interpretation of data, and probability. Analysis includes descriptive statistics, correlation and regression, confidence intervals and hypothesis testing. Use of appropriate technology is recommended.
- MATH 2305# DISCRETE MATHEMATICS (3-0) CREDIT 3**
Prerequisite: MATH 2413 with a grade of C or better
 A course designed to prepare math, computer science, and engineering majors for a background in abstraction, notation, and critical thinking for the mathematics most directly related to computer science. Topics include: logic, relations, functions, basic set theory, countability and counting arguments, proof techniques, mathematical induction, combinatorics, discrete probability, recursion, sequence and recurrence, elementary number theory, graph theory, and mathematical proof techniques.
- MATH 2318# LINEAR ALGEBRA (3-0) CREDIT 3**
Prerequisite: MATH 2414 with a grade of C or better
 Introduces and provides models for application of the concepts of vector algebra. Topics include finite dimensional vector spaces and their geometric significance; representing and solving systems of linear equations using multiple methods, including Gaussian elimination and matrix inversion; matrices; determinants; linear transformations; quadratic forms; eigenvalues and eigenvector; and applications in science and engine.
- MATH 2320# DIFFERENTIAL EQUATIONS (3-0) CREDIT 3**
Prerequisite: A grade of C or better in MATH 2414
 Ordinary differential equations, including linear equations, systems of equations, equations with variable coefficients, existence and uniqueness of solutions, series solutions, singular points, transform methods, and boundary value problems; application of differential equations to real-world problems.
- MATH 2412# PRECALCULUS (4-0) CREDIT 4 (020/090)**
Prerequisite: A grade of C or better in MATH 1314 or the equivalent preparation or ALEKS PPL score of 61 or higher. In addition to MATH 1314, knowledge of trigonometry would be beneficial.
 In-depth combined study of algebra, trigonometry, and other topics for calculus readiness.

COURSE DESCRIPTIONS

- MATH 2413# CALCULUS I (4-0) CREDIT 4 (020/090)**
Prerequisite: A grade of C or better in MATH 2312, MATH 2412, or ALEKS PPL score of 75 or higher, or equivalent preparation (a score of 620 or higher on the math section of the SAT or a score of 29 or higher on the math section of the ACT).
 Limits and continuity; the Fundamental Theorem of Calculus; definition of the derivative of a function and techniques of differentiation; applications of the derivative to maximizing or minimizing a function; the chain rule, mean value theorem, and rate of change problems; curve sketching; definite and indefinite integration of algebraic, trigonometric, and transcendental functions, with an application to calculation of areas.
- MATH 2414# CALCULUS II (4-0) CREDIT 4**
Prerequisite: A grade of C or better in MATH 2413.
 Differentiation and integration of transcendental functions; parametric equations and polar coordinates; techniques of integration; sequences and series; improper integrals.
- MATH 2415# CALCULUS III (4-0) CREDIT 4**
Prerequisite: A grade of C or better in MATH 2414.
 Advanced topics in calculus, including vectors and vector-valued functions, partial differentiation, Lagrange multipliers, multiple integrals, and Jacobians; application of the line integral, including Green's theorem, the Divergence theorem, and Stokes' theorem.
- MCHN 1343 MACHINE SHOP MATHEMATICS (3-0) CREDIT 3**
(Offered only in fall semester)
 Designed to prepare the student with technical, applied mathematics that will be necessary in future machine shop-related courses.
- MRKG 1311 PRINCIPLES OF MARKETING (3-0) CREDIT 3**
(Offered only in fall semester)
Prerequisite: Texas Success Initiative complete in Reading
 Introduction to the marketing mix functions and process. Includes identification of consumer and organizational needs and explanation of environmental issues.
- MUAP 1203# FRESHMAN VIOLIN (1-1) CREDIT 2**
Prerequisite: Consent of Department Chair
Corequisite: MUEN 1125 or permission of the department chair if course is not available.
 Individual instruction in violin. Students meet with their instructor for one private sixty (60) minute lesson per week and meet one hour per week for a required MUAP Seminar Class.
- MUAP 1204# FRESHMAN VIOLIN (1-1) CREDIT 2**
Prerequisite: A grade of C or higher in MUAP 1203
Corequisite: MUEN 1125 or permission of the department chair if course is not available.
 Individual instruction in violin. Students meet with their instructor for one private sixty (60) minute lesson per week and meet one hour per week for a required MUAP Seminar Class.
- MUAP 1207# FRESHMAN VIOLA (1-1) CREDIT 2**
Prerequisite: Consent of Department Chair
Corequisite: MUEN 1125 or permission of the department chair if course is not available.
 Individual instruction in viola. Students meet with their instructor for one private sixty (60) minute lesson per week and meet one hour per week for a required MUAP Seminar Class.
- MUAP 1208# FRESHMAN VIOLA (1-1) CREDIT 2**
Prerequisite: A grade of C or higher in MUAP 1207
Corequisite: MUEN 1125 or permission of the department chair if course is not available.
 Individual instruction in viola. Students meet with their instructor for one private sixty (60) minute lesson per week and meet one hour per week for a required MUAP Seminar Class.
- MUAP 1211# FRESHMAN CELLO (1-1) CREDIT 2**
Prerequisite: Consent of Department Chair
Corequisite: MUEN 1125 or permission of the department chair if course is not available.
 Individual instruction in cello. Students meet with their instructor for one private sixty (60) minute lesson per week and meet one hour per week for a required MUAP Seminar Class.
- MUAP 1212# FRESHMAN CELLO (1-1) CREDIT 2**
Prerequisite: A grade of C or higher in MUAP 1211
Corequisite: MUEN 1125 or permission of the department chair if course is not available.
 Individual instruction in cello. Students meet with their instructor for one private sixty (60) minute lesson per week and meet one hour per week for a required MUAP Seminar Class.

COURSE DESCRIPTIONS

- MUAP 1213# FRESHMAN BASS (1-1) CREDIT 2**
Prerequisite: Consent of Department Chair
Corequisite: MUEN 1125 or permission of the department chair if course is not available.
 Individual instruction in bass. Students meet with their instructor for one private sixty (60) minute lesson per week and meet one hour per week for a required MUAP Seminar Class.
- MUAP 1214# FRESHMAN BASS (1-1) CREDIT 2**
Prerequisite: A grade of C or higher in MUAP 1213
Corequisite: MUEN 1125 or permission of the department chair if course is not available.
 Individual instruction in bass. Students meet with their instructor for one private sixty (60) minute lesson per week and meet one hour per week for a required MUAP Seminar Class.
- MUAP 1219# FRESHMAN FLUTE (1-1) CREDIT 2**
Prerequisite: Consent of Department Chair
Corequisite: MUEN 1121 or permission of the department chair if course is not available.
 Individual instruction in flute. Students meet with their instructor for one private sixty (60) minute lesson per week and meet one hour per week for a required MUAP Seminar Class.
- MUAP 1220# FRESHMAN FLUTE (1-1) CREDIT 2**
Prerequisite: A grade of C or higher in MUAP 1219
Corequisite: MUEN 1121 or permission of the department chair if course is not available.
 Individual instruction in flute. Students meet with their instructor for one private sixty (60) minute lesson per week and meet one hour per week for a required MUAP Seminar Class.
- MUAP 1223# FRESHMAN OBOE (1-1) CREDIT 2**
Prerequisite: Consent of Department Chair
Corequisite: MUEN 1121 or permission of the department chair if course is not available.
 Individual instruction in oboe. Students meet with their instructor for one private sixty (60) minute lesson per week and meet one hour per week for a required MUAP Seminar Class.
- MUAP 1224# FRESHMAN OBOE (1-1) CREDIT 2**
Prerequisite: A grade of C or higher in MUAP 1223
Corequisite: MUEN 1121 or permission of the department chair if course is not available.
 Individual instruction in oboe. Students meet with their instructor for one private sixty (60) minute lesson per week and meet one hour per week for a required MUAP Seminar Class.
- MUAP 1227# FRESHMAN BASSOON (1-1) CREDIT 2**
Prerequisite: Consent of Department Chair
Corequisite: MUEN 1121 or permission of the department chair if course is not available.
 Individual instruction in bassoon. Students meet with their instructor for one private sixty (60) minute lesson per week and meet one hour per week for a required MUAP Seminar Class.
- MUAP 1228# FRESHMAN BASSOON (1-1) CREDIT 2**
Prerequisite: A grade of C or higher in MUAP 1227
Corequisite: MUEN 1121 or permission of the department chair if course is not available.
 Individual instruction in bassoon. Students meet with their instructor for one private sixty (60) minute lesson per week and meet one hour per week for a required MUAP Seminar Class.
- MUAP 1231# FRESHMAN CLARINET (1-1) CREDIT 2**
Prerequisite: Consent of Department Chair
Corequisite: MUEN 1121 or permission of the department chair if course is not available.
 Individual instruction in clarinet. Students meet with their instructor for one private sixty (60) minute lesson per week and meet one hour per week for a required MUAP Seminar Class.
- MUAP 1232# FRESHMAN CLARINET (1-1) CREDIT 2**
Prerequisite: A grade of C or higher in MUAP 1231
Corequisite: MUEN 1121 or permission of the department chair if course is not available.
 Individual instruction in clarinet. Students meet with their instructor for one private sixty (60) minute lesson per week and meet one hour per week for a required MUAP Seminar Class.
- MUAP 1235# FRESHMAN SAXOPHONE (1-1) CREDIT 2**
Prerequisite: Consent of Department Chair
Corequisite: MUEN 1121 or permission of the department chair if course is not available.
 Individual instruction in saxophone. Students meet with their instructor for one private sixty (60) minute lesson per week and meet one hour per week for a required MUAP Seminar Class.

COURSE DESCRIPTIONS

- MUAP 1236# FRESHMAN SAXOPHONE (1-1) CREDIT 2**
Prerequisite: A grade of C or higher in MUAP 1235
Corequisite: MUEN 1121 or permission of the department chair if course is not available.
 Individual instruction in saxophone. Students meet with their instructor for one private sixty (60) minute lesson per week and meet one hour per week for a required MUAP Seminar Class.
- MUAP 1239# FRESHMAN TRUMPET (1-1) CREDIT 2**
Prerequisite: Consent of Department Chair
Corequisite: MUEN 1121 or permission of the department chair if course is not available.
 Individual instruction in trumpet. Students meet with their instructor for one private sixty (60) minute lesson per week and meet one hour per week for a required MUAP Seminar Class.
- MUAP 1240# FRESHMAN TRUMPET (1-1) CREDIT 2**
Prerequisite: A grade of C or higher in MUAP 1239
Corequisite: MUEN 1121 or permission of the department chair if course is not available.
 Individual instruction in trumpet. Students meet with their instructor for one private sixty (60) minute lesson per week and meet one hour per week for a required MUAP Seminar Class.
- MUAP 1243# FRESHMAN FRENCH HORN (1-1) CREDIT 2**
Prerequisite: Consent of Department Chair
Corequisite: MUEN 1121 or permission of the department chair if course is not available.
 Individual instruction in French horn. Students meet with their instructor for one private sixty (60) minute lesson per week and meet one hour per week for a required MUAP Seminar Class.
- MUAP 1244# FRESHMAN FRENCH HORN (1-1) CREDIT 2**
Prerequisite: A grade of C or higher in MUAP 1243
Corequisite: MUEN 1121 or permission of the department chair if course is not available.
 Individual instruction in French horn. Students meet with their instructor for one private.
- MUAP 1247# FRESHMAN TROMBONE (1-1) CREDIT 2**
Prerequisite: Consent of Department Chair
Corequisite: MUEN 1121 or permission of the department chair if course is not available.
 Individual instruction in trombone. Students meet with their instructor for one private sixty (60) minute lesson per week and meet one hour per week for a required MUAP Seminar Class.
- MUAP 1248# FRESHMAN TROMBONE (1-1) CREDIT 2**
Prerequisite: A grade of C or higher in MUAP 1247
Corequisite: MUEN 1121 or permission of the department chair if course is not available.
 Individual instruction in trombone. Students meet with their instructor for one private sixty (60) minute lesson per week and meet one hour per week for a required MUAP Seminar Class.
- MUAP 1251# FRESHMAN BARITONE (1-1) CREDIT 2**
Prerequisite: Consent of Department Chair
Corequisite: MUEN 1121 or permission of the department chair if course is not available.
 Individual instruction in baritone. Students meet with their instructor for one private sixty (60) minute lesson per week and meet one hour per week for a required MUAP Seminar Class.
- MUAP 1252# FRESHMAN BARITONE (1-1) CREDIT 2**
Prerequisite: A grade of C or higher in MUAP 1251
Corequisite: MUEN 1121 or permission of the department chair if course is not available.
 Individual instruction in baritone. Students meet with their instructor for one private sixty (60) minute lesson per week and meet one hour per week for a required MUAP Seminar Class.
- MUAP 1255# FRESHMAN TUBA (1-1) CREDIT 2**
Prerequisite: Consent of Department Chair
Corequisite: MUEN 1121 or permission of the department chair if course is not available.
 Individual instruction in tuba. Students meet with their instructor for one private sixty (60) minute lesson per week and meet one hour per week for a required MUAP Seminar Class.
- MUAP 1256# FRESHMAN TUBA (1-1) CREDIT 2**
Prerequisite: A grade of C or higher in MUAP 1255
Corequisite: MUEN 1121 or permission of the department chair if course is not available.
 Individual instruction in tuba. Students meet with their instructor for one private sixty (60) minute lesson per week and meet one hour per week for a required MUAP Seminar Class.

COURSE DESCRIPTIONS

- MUAP 1259# FRESHMAN PERCUSSION (1-1) CREDIT 2**
Prerequisite: Consent of Department Chair
Corequisite: MUEN 1121 or permission of the department chair if course is not available.
 Individual instruction in percussion. Students meet with their instructor for one private sixty (60) minute lesson per week and meet one hour per week for a required MUAP Seminar Class.
- MUAP 1260# FRESHMAN PERCUSSION (1-1) CREDIT 2**
Prerequisite: A grade of C or higher in MUAP 1259
Corequisite: MUEN 1121 or permission of the department chair if course is not available.
 Individual instruction in percussion. Students meet with their instructor for one private sixty (60) minute lesson per week and meet one hour per week for a required MUAP Seminar Class.
- MUAP 1263# FRESHMAN GUITAR (1-1) CREDIT 2**
Prerequisite: Consent of Department Chair
Corequisite: MUEN 1139 or permission of the department chair if course is not available.
 Individual instruction in guitar. Students meet with their instructor for one private sixty (60) minute lesson per week and meet one hour per week for a required MUAP Seminar Class.
- MUAP 1264# FRESHMAN GUITAR (1-1) CREDIT 2**
Prerequisite: A grade of C or higher in MUAP 1263
Corequisite: MUEN 1139 or permission of the department chair if course is not available.
 Individual instruction in guitar. Students meet with their instructor for one private sixty (60) minute lesson per week and meet one hour per week for a required MUAP Seminar Class.
- MUAP 1267# FRESHMAN ORGAN (1-1) CREDIT 2**
Prerequisite: Consent of Department Chair.
Corequisite: MUEN 1141 or permission of the department chair if course is not available.
 Individual instruction in organ. Students meet with their instructor for one private sixty (60) minute lesson per week and meet one hour per week for a required MUAP Seminar Class.
- MUAP 1268# FRESHMAN ORGAN (1-1) CREDIT 2**
Prerequisite: A grade of C or higher in MUAP 1267
Corequisite: MUEN 1141 or permission of the department chair if course is not available.
 Individual instruction in organ. Students meet with their instructor for one private sixty (60) minute lesson per week and meet one hour per week for a required MUAP Seminar Class.
- MUAP 1271# FRESHMAN PIANO (1-1) CREDIT 2**
Prerequisite: Consent of Department Chair.
Corequisite: MUEN 1141 or permission of the department chair if course is not available.
 Individual instruction in piano. Students meet with their instructor for one private sixty (60) minute lesson per week and meet one hour per week for a required MUAP Seminar Class.
- MUAP 1272# FRESHMAN PIANO (1-1) CREDIT 2**
Prerequisite: A grade of C or higher in MUAP 1271
Corequisite: MUEN 1141 or permission of the department chair if course is not available.
 Individual instruction in piano. Students meet with their instructor for one private sixty (60) minute lesson per week and meet one hour per week for a required MUAP Seminar Class.
- MUAP 1283# FRESHMAN VOICE (1-1) CREDIT 2**
Prerequisite: Consent of Department Chair
Corequisite: MUEN 1141
 Individual instruction in voice. Students meet with their instructor for one private sixty (60) minute lesson per week and meet one hour per week for a required MUAP Seminar Class.
- MUAP 1284# FRESHMAN VOICE (1-1) CREDIT 2**
Prerequisite: A grade of C or higher in MUAP 1283
Corequisite: MUEN 1141
 Individual instruction in voice. Students meet with their instructor for one private sixty (60) minute lesson per week and meet one hour per week for a required MUAP Seminar Class.
- MUAP 2203# SOPHOMORE VIOLIN (1-1) CREDIT 2**
Prerequisite: A grade of C or higher in MUAP 1204
Corequisite: MUEN 1125 or permission of the department chair if course is not available.
 Individual instruction in violin. Students meet with their instructor for one private sixty (60) minute lesson per week and meet one hour per week for a required MUAP Seminar Class.

COURSE DESCRIPTIONS

- MUAP 2204# SOPHOMORE VIOLIN (1-1) CREDIT 2**
Prerequisite: A grade of C or higher in MUAP 2203
Corequisite: MUEN 1125 or permission of the department chair if course is not available.
 Individual instruction in violin. Students meet with their instructor for one private sixty (60) minute lesson per week and meet one hour per week for a required MUAP Seminar Class.
- MUAP 2207# SOPHOMORE VIOLA (1-1) CREDIT 2**
Prerequisite: A grade of C or higher in MUAP 1208
Corequisite: MUEN 1125 or permission of the department chair if course is not available.
 Individual instruction in viola. Students meet with their instructor for one private sixty (60) minute lesson per week and meet one hour per week for a required MUAP Seminar Class.
- MUAP 2208# SOPHOMORE VIOLA (1-1) CREDIT 2**
Prerequisite: A grade of C or higher in MUAP 2207
Corequisite: MUEN 1125 or permission of the department chair if course is not available.
 Individual instruction in viola. Students meet with their instructor for one private sixty (60) minute lesson per week and meet one hour per week for a required MUAP Seminar Class.
- MUAP 2211# SOPHOMORE CELLO (1-1) CREDIT 2**
Prerequisite: A grade of C or higher in MUAP 1212
Corequisite: MUEN 1125 or permission of the department chair if course is not available.
 Individual instruction in cello. Students meet with their instructor for one private sixty (60) minute lesson per week and meet one hour per week for a required MUAP Seminar Class.
- MUAP 2212# SOPHOMORE CELLO (1-1) CREDIT 2**
Prerequisite: A grade of C or higher in MUAP 2211
Corequisite: MUEN 1125 or permission of the department chair if course is not available.
 Individual instruction in cello. Students meet with their instructor for one private sixty (60) minute lesson per week and meet one hour per week for a required MUAP Seminar Class.
- MUAP 2213# SOPHOMORE BASS (1-1) CREDIT 2**
Prerequisite: A grade of C or higher in MUAP 1214
Corequisite: MUEN 1125 or permission of the department chair if course is not available.
 Individual instruction in bass. Students meet with their instructor for one private sixty (60) minute lesson per week and meet one hour per week for a required MUAP Seminar Class.
- MUAP 2214# SOPHOMORE BASS (1-1) CREDIT 2**
Prerequisite: A grade of C or higher in MUAP 2213
Corequisite: MUEN 1125 or permission of the department chair if course is not available.
 Individual instruction in bass. Students meet with their instructor for one private sixty (60) minute lesson per week and meet one hour per week for a required MUAP Seminar Class.
- MUAP 2215# SOPHOMORE ELECTRIC BASS (1-1) CREDIT 2**
Prerequisite: A grade of C or higher in MUAP 1216
Corequisite: MUEN 1139 or permission of the department chair if course is not available.
 Individual instruction in electric bass. Students meet with their instructor for one private sixty (60) minute lesson per week and meet one hour per week for a required MUAP Seminar Class.
- MUAP 2216# SOPHOMORE ELECTRIC BASS (1-1) CREDIT 2**
Prerequisite: A grade of C or higher in MUAP 2215
Corequisite: MUEN 1139 or permission of the department chair if course is not available.
 Individual instruction in electric bass. Students meet with their instructor for one private sixty (60) minute lesson per week and meet one hour per week for a required MUAP Seminar Class.
- MUAP 2219# SOPHOMORE FLUTE (1-1) CREDIT 2**
Prerequisite: A grade of C or higher in MUAP 1220
Corequisite: MUEN 1121 or permission of the department chair if course is not available.
 Individual instruction in flute. Students meet with their instructor for one private sixty (60) minute lesson per week and meet one hour per week for a required MUAP Seminar Class.
- MUAP 2220# SOPHOMORE FLUTE (1-1) CREDIT 2**
Prerequisite: A grade of C or higher in MUAP 2219
Corequisite: MUEN 1121 or permission of the department chair if course is not available.
 Individual instruction in flute. Students meet with their instructor for one private sixty (60) minute lesson per week and meet one hour per week for a required MUAP Seminar Class.

COURSE DESCRIPTIONS

- MUAP 2223# SOPHOMORE OBOE (1-1) CREDIT 2**
Prerequisite: A grade of C or higher in MUAP 1224
Corequisite: MUEN 1121 or permission of the department chair if course is not available.
 Individual instruction in oboe. Students meet with their instructor for one private sixty (60) minute lesson per week and meet one hour per week for a required MUAP Seminar Class.
- MUAP 2224# SOPHOMORE OBOE (1-1) CREDIT 2**
Prerequisite: A grade of C or higher in MUAP 2223
Corequisite: MUEN 1121 or permission of the department chair if course is not available.
 Individual instruction in oboe. Students meet with their instructor for one private sixty (60) minute lesson per week and meet one hour per week for a required MUAP Seminar Class.
- MUAP 2227# SOPHOMORE BASSOON (1-1) CREDIT 2**
Prerequisite: A grade of C or higher in MUAP 1228
Corequisite: MUEN 1121 or permission of the department chair if course is not available.
 Individual instruction in bassoon. Students meet with their instructor for one private sixty (60) minute lesson per week and meet one hour per week for a required MUAP Seminar Class.
- MUAP 2228# SOPHOMORE BASSOON (1-1) CREDIT 2**
Prerequisite: A grade of C or higher in MUAP 2227
Corequisite: MUEN 1121 or permission of the department chair if course is not available.
 Individual instruction in bassoon. Students meet with their instructor for one private sixty (60) minute lesson per week and meet one hour per week for a required MUAP Seminar Class.
- MUAP 2231# SOPHOMORE CLARINET (1-1) CREDIT 2**
Prerequisite: A grade of C or higher in MUAP 1232
Corequisite: MUEN 1121 or permission of the department chair if course is not available.
 Individual instruction in clarinet. Students meet with their instructor for one private sixty (60) minute lesson per week and meet one hour per week for a required MUAP Seminar Class.
- MUAP 2232# SOPHOMORE CLARINET (1-1) CREDIT 2**
Prerequisite: A grade of C or higher in MUAP 2231
Corequisite: MUEN 1121 or permission of the department chair if course is not available.
 Individual instruction in clarinet. Students meet with their instructor for one private sixty (60) minute lesson per week and meet one hour per week for a required MUAP Seminar Class.
- MUAP 2235# SOPHOMORE SAXOPHONE (1-1) CREDIT 2**
Prerequisite: A grade of C or higher in MUAP 1236
Corequisite: MUEN 1121 or permission of the department chair if course is not available.
 Individual instruction in saxophone. Students meet with their instructor for one private sixty (60) minute lesson per week and meet one hour per week for a required MUAP Seminar Class.
- MUAP 2236# SOPHOMORE SAXOPHONE (1-1) CREDIT 2**
Prerequisite: A grade of C or higher in MUAP 2235
Corequisite: MUEN 1121 or permission of the department chair if course is not available.
 Individual instruction in saxophone. Students meet with their instructor for one private sixty (60) minute lesson per week and meet one hour per week for a required MUAP Seminar Class.
- MUAP 2239# SOPHOMORE TRUMPET (1-1) CREDIT 2**
Prerequisite: A grade of C or higher in MUAP 1240
Corequisite: MUEN 1121 or permission of the department chair if course is not available.
 Individual instruction in trumpet. Students meet with their instructor for one private sixty (60) minute lesson per week and meet one hour per week for a required MUAP Seminar Class.
- MUAP 2240# SOPHOMORE TRUMPET (1-1) CREDIT 2**
Prerequisite: A grade of C or higher in MUAP 2239
Corequisite: MUEN 1121 or permission of the department chair if course is not available.
 Individual instruction in trumpet. Students meet with their instructor for one private sixty (60) minute lesson per week and meet one hour per week for a required MUAP Seminar Class.
- MUAP 2243# SOPHOMORE FRENCH HORN (1-1) CREDIT 2**
Prerequisite: A grade of C or higher in MUAP 1244
Corequisite: MUEN 1121 or permission of the department chair if course is not available.
 Individual instruction in French horn. Students meet with their instructor for one private sixty (60) minute lesson per week and meet one hour per week for a required MUAP Seminar Class.

COURSE DESCRIPTIONS

- MUAP 2244# SOPHOMORE FRENCH HORN (1-1) CREDIT 2**
Prerequisite: A grade of C or higher in MUAP 2243
Corequisite: MUEN 1121 or permission of the department chair if course is not available.
 Individual instruction in French horn. Students meet with their instructor for one private sixty (60) minute lesson per week and meet one hour per week for a required MUAP Seminar Class.
- MUAP 2247# SOPHOMORE TROMBONE (1-1) CREDIT 2**
Prerequisite: A grade of C or higher in MUAP 1248
Corequisite: MUEN 1121 or permission of the department chair if course is not available.
 Individual instruction in trombone. Students meet with their instructor for one private sixty (60) minute lesson per week and meet one hour per week for a required MUAP Seminar Class.
- MUAP 2248# SOPHOMORE TROMBONE (1-1) CREDIT 2**
Prerequisite: A grade of C or higher in MUAP 2247
Corequisite: MUEN 1121 or permission of the department chair if course is not available.
 Individual instruction in trombone. Students meet with their instructor for one private sixty (60) minute lesson per week and meet one hour per week for a required MUAP Seminar Class.
- MUAP 2251# SOPHOMORE BARITONE (1-1) CREDIT 2**
Prerequisite: A grade of C or higher in MUAP 1252
Corequisite: MUEN 1121 or permission of the department chair if course is not available.
 Individual instruction in baritone. Students meet with their instructor for one private sixty (60) minute lesson per week and meet one hour per week for a required MUAP Seminar Class.
- MUAP 2252# SOPHOMORE BARITONE (1-1) CREDIT 2**
Prerequisite: A grade of C or higher in MUAP 2251
Corequisite: MUEN 1121 or permission of the department chair if course is not available.
 Individual instruction in baritone. Students meet with their instructor for one private sixty (60) minute lesson per week and meet one hour per week for a required MUAP Seminar Class.
- MUAP 2255# SOPHOMORE TUBA (1-1) CREDIT 2**
Prerequisite: A grade of C or higher in MUAP 1256
Corequisite: MUEN 1121 or permission of the department chair if course is not available.
 Individual instruction in tuba. Students meet with their instructor for one private sixty (60) minute lesson per week and meet one hour per week for a required MUAP Seminar Class.
- MUAP 2256# SOPHOMORE TUBA (1-1) CREDIT 2**
Prerequisite: A grade of C or higher in MUAP 2255
Corequisite: MUEN 1121 or permission of the department chair if course is not available.
 Individual instruction in tuba. Students meet with their instructor for one private sixty (60) minute lesson per week and meet one hour per week for a required MUAP Seminar Class.
- MUAP 2259# SOPHOMORE PERCUSSION (1-1) CREDIT 2**
Prerequisite: A grade of C or higher in MUAP 1260
Corequisite: MUEN 1121 or permission of the department chair if course is not available.
 Individual instruction in percussion. Students meet with their instructor for one private sixty (60) minute lesson per week and meet one hour per week for a required MUAP Seminar Class.
- MUAP 2260# SOPHOMORE PERCUSSION (1-1) CREDIT 2**
Prerequisite: A grade of C or higher in MUAP 2259
Corequisite: MUEN 1121 or permission of the department chair if course is not available.
 Individual instruction in percussion. Students meet with their instructor for one private sixty (60) minute lesson per week and meet one hour per week for a required MUAP Seminar Class.
- MUAP 2263# SOPHOMORE GUITAR (1-1) CREDIT 2**
Prerequisite: A grade of C or higher in MUAP 1264
Corequisite: MUEN 1139 or permission of the department chair if course is not available.
 Individual instruction in guitar. Students meet with their instructor for one private sixty (60) minute lesson per week and meet one hour per week for a required MUAP Seminar Class.
- MUAP 2264# SOPHOMORE GUITAR (1-1) CREDIT 2**
Prerequisite: A grade of C or higher in MUAP 2263
Corequisite: MUEN 1139 or permission of the department chair if course is not available.
 Individual instruction in guitar. Students meet with their instructor for one private sixty (60) minute lesson per week and meet one hour per week for a required MUAP Seminar Class.

COURSE DESCRIPTIONS

- MUAP 2267# SOPHOMORE ORGAN (1-1) CREDIT 2**
Prerequisite: Consent of Department Chair
Corequisite: MUEN 1141 or permission of the department chair if course is not available.
 Individual instruction in organ. Students meet with their instructor for one private sixty (60) minute lesson per week and meet one hour per week for a required MUAP Seminar Class.
- MUAP 2268# SOPHOMORE ORGAN (1-1) CREDIT 2**
Prerequisite: A grade of C or higher in MUAP 2267
Corequisite: MUEN 1141 or permission of the department chair if course is not available.
 Individual instruction in organ. Students meet with their instructor for one private sixty (60) minute lesson per week and meet one hour per week for a required MUAP Seminar Class.
- MUAP 2271# SOPHOMORE PIANO (1-1) CREDIT 2**
Prerequisite: Consent of Department Chair or a grade of C or higher in MUAP 1272
Corequisite: MUEN 1141 or permission of the department chair if course is not available.
 Individual instruction in piano. Students meet with their instructor for one private sixty (60) minute lesson per week and meet one hour per week for a required MUAP Seminar Class.
- MUAP 2272# SOPHOMORE PIANO (1-1) CREDIT 2**
Prerequisite: A grade of C or higher in MUAP 2271
Corequisite: MUEN 1141 or permission of the department chair if course is not available.
 Individual instruction in piano. Students meet with their instructor for one private sixty (60) minute lesson per week and meet one hour per week for a required MUAP Seminar Class.
- MUAP 2283# SOPHOMORE VOICE (1-1) CREDIT 2**
Prerequisite: Consent of Department Chair or a grade of C or higher in MUAP 1284
Corequisite: MUEN 1141
 Individual instruction in voice. Students meet with their instructor for one private sixty (60) minute lesson per week and meet one hour per week for a required MUAP Seminar Class.
- MUAP 2284# SOPHOMORE VOICE (1-1) CREDIT 2**
Prerequisite: A grade of C or higher in MUAP 2283
Corequisite: MUEN 1141
 Individual instruction in voice. Students meet with their instructor for one private sixty (60) minute lesson per week and meet one hour per week for a required MUAP Seminar Class.
- MUEN 1121# CONCERT BAND (0-3) CREDIT 1**
 The music department offers two years of training in the reading and performing of music for the concert band and wind ensembles. The repertoire covers the finest materials from band music literature.
- MUEN 1123# JAZZ ENSEMBLE (0-3) CREDIT 1**
Prerequisite: Written permission of the instructor.
 The music department offers this course to train musicians in the styles of popular music which includes Dixieland, swing, and various styles of jazz to contemporary form. This course includes training in improvisation.
- MUEN 1125# CONCERT ORCHESTRA (0-3) CREDIT 1**
 Study of symphonic repertoire, from Baroque to Contemporary, through participation in instrumental performances.
- MUEN 1141# COLLEGE CHOIR (0-3) CREDIT 1**
 Participation in the College Concert Choir is open to all students. Students will sing in a variety of music styles and improve their choral singing techniques. Performances include concerts in and around Victoria and may include a concert with other ensembles.
- MUEN 1151# CHORALIERS (0-3) CREDIT 1**
Prerequisite: Written permission of the instructor.
 This group is a select group of mixed voices chosen for additional musical performance and training, including trio and quartet work as well as small ensembles. Repertoire includes madrigals and light popular works.
- MUSI 1116# SIGHT SINGING & EAR TRAINING I (1-1) CREDIT 1**
Prerequisite: Texas Success Initiative complete in Reading
Corequisite: MUSI 1311
(Offered only in fall semester)
 Singing tonal music in treble and bass clefs, and aural study of elements of music, such as scales, intervals and chords, and dictation of basic rhythm, melody and diatonic harmony.
- MUSI 1117# SIGHT SINGING & EAR TRAINING II (1-1) CREDIT 1**
Prerequisite: A grade of D or better in MUSI 1116
Corequisite: MUSI 1312
(Offered only in spring semester)
 Singing tonal music in various clefs, continued aural study of the elements of music, and dictation of intermediate rhythm, melody, and diatonic harmony.

COURSE DESCRIPTIONS

- MUSI 1181# PIANO CLASS I (1-1) CREDIT 1**
Co-enrollment or completion of MUSI 1311 with a grade of D or better
(Typically offered only in fall semester)
 Class instruction in the fundamentals of keyboard technique for beginning piano students. Piano Class 1181 is designed for beginning piano students. Learning will take place primarily in class. This is a hands-on class. New concepts are introduced through demonstration and reinforced with drills. Students must reinforce these concepts with practice outside of class.
- MUSI 1182# PIANO CLASS II (1-1) CREDIT 1**
Prerequisite: A grade of C or better in MUSI 1181
(Typically offered only in spring semester)
 Advanced beginning class instruction in the fundamentals of keyboard technique. Piano Class 1182 is a continuation of MUSI 1181. Learning will take place primarily in class. This is a hands-on class. New concepts are introduced through demonstration and reinforced with drills. Students must reinforce these concepts with practice outside of class.
- MUSI 1306# MUSIC APPRECIATION (3-0) CREDIT 3 (050/090)**
Prerequisite: Texas Success Initiative complete in Reading and Writing.
 Understanding music through the study of cultural periods, major composers, and musical elements. Illustrated with audio recordings and live performances. (Does not apply to a music major degree.)
- MUSI 1307# MUSIC LITERATURE (single-semester course) (3-0) CREDIT 3 (050/090)**
Prerequisite: Texas Success Initiative complete in Reading and Writing.
(Offered only in spring semesters)
 A survey of the styles and forms of music as it developed from the middle ages to the present. This course will familiarize the student with cultural context, terminology, genres, and notation.
- MUSI 1310# AMERICAN MUSIC (3-0) CREDIT 3 (050/090)**
Prerequisite: Texas Success Initiative complete in Reading and Writing.
 General survey of various styles of music in America. Topics may include jazz, ragtime, folk, rock, and contemporary art music.
- MUSI 1311# MUSIC THEORY I (3-0) CREDIT 3**
Prerequisite: Texas Success Initiative complete in Reading. Ability to read notes on the treble and bass staves; ability to read and count basic rhythms in 2/4, 3/4, and 4/4 using whole notes, dotted half notes, half notes, dotted quarter notes, quarter notes, eighth notes, dotted eighth notes, and sixteenth notes. A study guide is available from the department.
Corequisite: MUSI 1116
(Offered only in fall semester)
 The study of analysis and writing of tonal melody and diatonic harmony, including fundamental music concepts, scales, intervals, chords, 7th chords, and early four-part writing. Analysis of small compositional forms. Optional correlated study at the keyboard.
- MUSI 1312# MUSIC THEORY II (3-0) CREDIT 3**
Prerequisite: A grade of D or better in MUSI 1311
Corequisite: MUSI 1117
(Offered only in spring semester)
 The study of analysis and writing of tonal melody and diatonic harmony, including all diatonic chords and seventh chords in root position and inversions, non-chord tones, and functional harmony. Introduction to more complex topics, such as modulation, may occur. Optional correlated study at the keyboard.
- MUSI 2116# SIGHT SINGING & EAR TRAINING III (1-1) CREDIT 1**
Prerequisite: A grade of D or better in MUSI 1117
Corequisite: MUSI 2311
(Offered only in fall semester)
 Singing more difficult tonal music in various clefs, aural study including dictation of more complex rhythm, melody, chromatic harmony, and extended tertian structures.
- MUSI 2117# SIGHT SINGING & EAR TRAINING IV (1-1) CREDIT 1**
Prerequisite: A grade of D or better in MUSI 2116
Corequisite: MUSI 2312
(Offered only in spring semester)
 Singing advanced tonal music and introduction of modal and post-tonal melodies. Aural study including dictation of advanced rhythm, melody, and harmony.
- MUSI 2181# PIANO CLASS III (1-1) CREDIT 1**
Prerequisite: A grade of C or better in MUSI 1182
(Offered only in fall semester)
 Intermediate class instruction of keyboard technique. Piano Class 2181 is a continuation of MUSI 1182. Learning will take place primarily in class. This is a hands-on class. New concepts are introduced through demonstration and reinforced with drills. Students must reinforce these concepts with practice outside of class.

COURSE DESCRIPTIONS

- MUSI 2182# PIANO CLASS IV (1-1) CREDIT 1**
Prerequisite: A grade of C or better in MUSI 2181
(Offered only in spring semester)
 Advanced class instruction of keyboard technique.
- MUSI 2311# MUSIC THEORY III (3-0) CREDIT 3**
Prerequisite: A grade of D or better in MUSI 1312
Corequisite: MUSI 2116
(Offered only in fall semester)
 Advanced harmony voice leading, score analysis and writing of more advanced tonal harmony including chromaticism and extended-tertian structures. Optional correlated study at the keyboard.
- MUSI 2312# MUSIC THEORY IV (3-0) CREDIT 3**
Prerequisite: A grade of D or better in MUSI 2311
Corequisite: MUSI 2117
(Offered only in spring semester)
 Continuation of advanced chromaticism and survey of analytical and compositional procedures in post-tonal music. Optional correlated study at the keyboard.
- PFPB 2308 PIPING STANDARDS & MATERIALS (3-0) CREDIT 3**
 Identification, description, and application of piping standards and specifications. Includes identification and use of various metallic and non-metallic piping materials, identification and installation of valves, and material take-offs.
- PHED 1110# SELF DEFENSE (0-3) CREDIT 1**
 This course is an introduction to the fundamentals of several aspects of the “martial arts” including karate, kung fu, judo, jiu-jitsu, and aikido. There will be focus and emphasis on Karate and Judo. While class time will be focused on learning a karate form, time and attention will be spent on practical application. There will be some limited physical contact between all participants in this class.
- PHED 1114# WEIGHT TRAINING (0-3) CREDIT 1**
 A physical fitness course designed to develop muscular strength and endurance through weight lifting. Free weights, universal multi-station and Badger Magnum machines will be used. Some aerobic activities will be included.
- PHED 1116# YOGA (0-3) CREDIT 1**
 Power Yoga integrates body and mind for total performance, and is therefore an effective means of achieving body/mind health. Stretching and deep breathing techniques for flexibility, stress reduction and relaxation, plus a variety of strength, endurance and cardiovascular training techniques using music to enhance the experience will be the focus of this class. Power Yoga is appropriate for all ages and all fitness levels to achieve and maintain overall health and fitness.
- PHED 1119# GROUP PHYSICAL FITNESS/WEIGHT TRAINING & CONDITIONING (0-3) CREDIT 1**
 A group fitness barbell weight course specifically designed to study and practice physiological principles related to overall development of health-related fitness components. This course will concentrate on assisting students with individually designing a unique weight training, aerobic, and weight management program to meet each student's goals and objectives. This course will utilize a variety of resistance equipment that will strengthen the entire body & challenge all major muscle groups. Workouts to inspiring music motivate students to reach their health-related fitness goals. Students will also participate in a variety of cardiovascular workouts, including, fitness walking, jogging, circuits, etc.
- PHED 1122# ADVANCED BASKETBALL (0-3) CREDIT 1**
 An advanced activity class with emphasis on learning the advanced skills and strategy of basketball through lectures, demonstration of skills, individual/group practice drills, and competition. Also included is training on strategic game play and conditioning for basketball.
- PHED 1123# ADVANCED VOLLEYBALL (0-3) CREDIT 1**
 An advanced activity class with emphasis on learning the advanced skills and strategy of volleyball through lectures, demonstrations of skills, individual/group practices drills, and competition. Also included is training on strategic game play and conditioning for volleyball.
- PHED 1126# TEAM SPORTS – VOLLEYBALL/BASKETBALL (0-3) CREDIT 1**
 An activity course with emphasis on basic individual fundamental skills and strategies of team sports: volleyball and basketball. Instruction includes demonstration, individual and group drills, and intra-class competition. Also included is an overview of scoring and officiating, etiquette, rules, terminology, and equipment used for each sport.
- PHED 1127# RACQUET SPORTS: TENNIS/PICKLE BALL/BADMINTON (0-3) CREDIT 1**
 An activity course with emphasis on basic individual fundamental skills and strategies of racquet sports: Tennis, Badminton, Pickle Ball. Instruction includes demonstration, individual and group drills, and intra-class competition. Also included is an overview of scoring and officiating, etiquette, rules, terminology, and equipment used for each sport.
- PHED 1301# FOUNDATIONS OF KINESIOLOGY (3-0) CREDIT 3**
 The purpose of this course is to provide students with an introduction to human movement that includes the historical development of physical education, exercise science, and sport. This course offers the student both an introduction to the knowledge base, as well as, information on expanding career opportunities.

COURSE DESCRIPTIONS

- PHED 1308# SPORTS OFFICIATING (3-0) CREDIT 3**
 This course is designed to provide the student with the knowledge and expertise necessary to officiate intramural, junior high, and high school volleyball and basketball. The classroom component of this course will involve a thorough study of the volleyball and basketball rule books along with the psychology of officiating. The on court component of this course will develop the proper mechanics of officiating volleyball and basketball. This class will require the student to participate in on court activity relating to both volleyball and basketball.
- PHED 1321# COACHING/SPORTS/ATHLETICS I (3-0) CREDIT 3**
 Study of the history, theories, philosophies, rules, and terminology of competitive sports. This course is designed to study the discipline of coaching as well as several sub-disciplines relevant to the field. These sub-disciplines include: sports psychology, motor learning, growth and development, sport issues, sport in society, philosophy of sport, risk management in sport and technology in sport. Students will study each sub-discipline and observe their application.
- PHED 1331# PHYSICAL EDUCATION FOR ELEMENTARY EDUCATION MAJORS (3-0) CREDIT 3**
 This course is designed to introduce teacher candidates to methods, materials, and activities for teaching developmentally appropriate physical education in the preschool, primary, and intermediate grades. Teacher candidates will identify and apply effective teacher process behaviors while presenting movement activities.
- PHED 1338# CONCEPTS OF PHYSICAL FITNESS (2-2) CREDIT 3**
 This course is designed to familiarize students with knowledge, understanding and values of health related fitness and its influence on the quality of life emphasizing the development and implementation of fitness programs.
- PHED 2356# CARE AND PREVENTION OF ATHLETIC INJURIES (3-0) CREDIT 3**
Prerequisite: Texas Success Initiative complete in Reading and Writing.
 Prevention and care of athletic injuries with emphasis on qualities of a good athletic trainer, avoiding accidents and injuries, recognizing signs and symptoms of specific sports injuries and conditions, immediate and long-term care of injuries, and administration procedures in athletic training.
- PHIL 1301# INTRODUCTION TO PHILOSOPHY (3-0) CREDIT 3 (040/090)**
Prerequisite: Texas Success Initiative complete in Reading and Writing.
 A study of major issues in philosophy and/or the work of major philosophical figures in philosophy. Topics in philosophy may include theories of reality, theories of knowledge, theories of value, and their practical applications.
- PHYS 1303# STARS AND GALAXIES (3-0) CREDIT 3 (030/090)**
Prerequisite: TSI complete in Reading and Math.
 Study of stars, galaxies, and the universe outside our solar system. This course does not include a laboratory.
- PHYS 1304# SOLAR SYSTEM (3-0) CREDIT 3 (030/090)**
Prerequisite: TSI complete in Reading and Math.
 Study of the sun and its solar system, including its origin. This course does not include a laboratory.
- PHYS 1310# ELEMENTARY PHYSICS (3-1) CREDIT 3 (030/090)**
Prerequisite: A grade of C or better in MATH 1332, MATH 1314 or high school Algebra II
 This course is intended for liberal arts, technical certificate and other non-science majors who require a one-semester course. The course includes a one-hour laboratory component. The course is a study of the basic laws of physics and includes topics of mechanics, heat, vibrations, wave motion and sound. Emphasis is on solutions to physics problems; a knowledge of Algebra is essential.
- PHYS 1401# COLLEGE PHYSICS I (3-3) CREDIT 4 (030/090)**
Prerequisite: A "C" or better in Math 1314 – College Algebra AND MATH 1316 – Plane Trigonometry OR MATH 2312/2412 – Pre-Calculus
(Offered only in fall semester)
 Fundamental principles of physics, using algebra and trigonometry; the principles and applications of classical mechanics and thermodynamics, including harmonic motion, mechanical waves and sound, physical systems, Newton's Laws of Motion, and gravitation and other fundamental forces; with emphasis on problem solving.
- PHYS 1402# COLLEGE PHYSICS II (3-3) CREDIT 4 (030/090)**
Prerequisite: A grade of C or better in PHYS 1401
(Offered only in spring semester)
 Fundamental principles of physics, using algebra and trigonometry; the principles and applications of electricity and magnetism, including circuits, electrostatics, electromagnetism, waves, sound, light, optics, and modern physics topics; with emphasis on problem solving.

COURSE DESCRIPTIONS

- PHYS 2425# UNIVERSITY PHYSICS I (3-3) CREDIT 4 (030/090)**
Prerequisite: A “C” or better in MATH 2413.
(Offered only in fall semester)
 Fundamental principles of physics, using calculus, for science, computer science, and engineering majors; the principles and applications of classical mechanics, including harmonic motion, physical systems and thermodynamics; and emphasis on problem solving.
- PHYS 2426# UNIVERSITY PHYSICS II (3-3) CREDIT 4 (030/090)**
Prerequisite: A “C” or better in PHYS 2425 and MATH 2414
(Offered only in spring semester)
 Principles of physics for science, computer science, and engineering majors, using calculus, involving the principles of electricity and magnetism, including circuits, electromagnetism, waves, sound, light and optics.
- PSYC 2301# GENERAL PSYCHOLOGY (3-0) CREDIT 3 (080/090)**
Prerequisite: Texas Success Initiative complete in Reading and Writing.
Corequisite: None or co-enrolled in an appropriate developmental course or Non-Course Based Option (NCBO) for students who are not TSI complete.
 General Psychology is a survey of the major psychological topics, theories and approaches to the scientific study of behavior and mental processes.
- PSYC 2314# LIFESPAN GROWTH AND DEVELOPMENT (3-0) CREDIT 3**
Prerequisite: A grade of “C” or better in PSYC 2301.
 Life-Span Growth and Development is a study of social, emotional, cognitive and physical factors and influences of a developing human from conception to death.
- PSYC 2317# STATISTICAL METHODS IN PSYCHOLOGY (3-0) CREDIT 3**
Prerequisite(s): Texas Success Initiative complete in Reading and Writing. MATH 1314 (C or higher) PSYC 2301 (C or higher)
This is an elective course and will not substitute for PSYC 2301 or PSYC 2314.
 This course covers descriptive and inferential statistics used in psychological research and assessment. It includes measurement, characteristics of distributions; measures of central tendency and variability; transformed scores; correlation and regression; probability theory; and hypotheses testing and inference.
- PSYC 2319# SOCIAL PSYCHOLOGY (3-0) CREDIT 3**
Prerequisite: A grade of C or better in PSYC 2301
This is an elective course and will not substitute for PSYC 2301 or PSYC 2314.
 Study of individual behavior within the social environment. Topics may include sociopsychological processes, attitude formation and change, interpersonal relations, group processes, self, social cognition, and research methods. (PSYC 2319 is included in the Psychology Field of Study.)
- PSYC 2320# ABNORMAL PSYCHOLOGY (3-0) CREDIT 3**
Prerequisite: A grade of C or better in PSYC 2301
This is an elective course and will not substitute for PSYC 2301 or PSYC 2314.
 This course provides an introduction to the psychological, biological, and socio-cultural factors involved in the development, diagnosis, and treatment of psychological disorders. It includes a review of the historical understanding of abnormal behavior and the development of modern diagnostic systems. It includes discussion of psychological research and practice as it relates to mental health and psychological functioning, as well as legal and ethical issues.
- PSYC 2330# BIOLOGICAL PSYCHOLOGY (3-0) CREDIT 3**
Prerequisite(s): Texas Success Initiative complete in Reading and Writing. PSYC 2301 (C or higher).
This is an elective course and will not substitute for PSYC 2301 or PSYC 2314.
 An introduction to the biological bases of behavior. Topics include evolution, genetics, research methods in behavioral neuroscience, motivation and emotion, sensation and perception, learning and memory, lifespan development, cognition, psychological disorders, and other complex behaviors.
- PTAC 1302 INTRO TO PROCESS TECHNOLOGY (3-1) CREDIT 3**
 An introduction overview of the various processing industries. This is a survey of all process technology courses in the program. Topics include the roles, responsibilities, and work environment of a process technician; basic processes, equipment and systems; safety, environmental, and quality concepts.
- PTAC 1308 SAFETY, HEALTH AND ENVIRONMENT I (3-1) CREDIT 3**
(Offered only in spring semester)
 An overview of safety, health and environmental issues in the performance of all job tasks in process industries. Topics include components of a typical plant safety and environmental program; the role of a process technician in relation to safety, health, and environment; and safety, health, and environmental equipment uses.

COURSE DESCRIPTIONS

- PTAC 1354 INDUSTRIAL PROCESSES (3-1) CREDIT 3**
Prerequisite: A grade of C or better in PTAC 1410 and 1432 or Instructor approval
(Offered only in fall semester)
 The study of the common types of industrial processes.
- PTAC 1410 PROCESS TECHNOLOGY I – EQUIPMENT (3-2) CREDIT 4**
Prerequisite/Corequisite: A grade of C or better in PTAC 1302 or coenrollment in PTAC 1302
(Offered only in fall semester)
 Introduction to the use of common process equipment. Topics include process equipment components, terminology to describe components of process equipment, basic functions of process equipment, and the scientific principles associated with process equipment.
- PTAC 1432 PROCESS INSTRUMENTATION I (3-2) CREDIT 4**
Prerequisite/Corequisite: A grade of C or better in PTAC 1302 or coenrollment in PTAC 1302
(Offered only in fall semester)
 Study of the instruments and control systems used in the process industry including terminology, process variables, symbols, control loops, and basic troubleshooting.
- PTAC 2314 PRINCIPLES OF QUALITY (2-2) CREDIT 3**
Prerequisite: Texas Success Initiative complete in Reading and Math
(Offered only in fall semester)
 Study of the background and application of quality concepts. Topics include team skills, quality tools, statistics, economics, and continuous improvement.
- PTAC 2348 SAFETY, HEALTH AND ENVIRONMENT II (3-0) CREDIT 3**
Prerequisite: A grade of C or better in PTAC 1308 or Instructor Approval
 Continued instruction in the application of concepts presented in Safety, Health, and Environment I. Emphasis on emergency response concepts. Topics include demonstration of appropriate response to emergency situations; recognition of hazardous situations for personnel, environment, and community; and application of team skills in response to emergency situations.
- PTAC 2386 INTERNSHIP - PROCESS TECHNOLOGY TECHNICIAN (0-0-12) CREDIT 4**
Prerequisite: *A grade of C or better in PTAC 1410 and 1432. *Program coordinator approval required.
 A work-based learning experience that enables the student to apply specialized occupational theory, skills, and concepts. A learning plan is developed by the college and the employer.
- PTAC 2420 PROCESS TECHNOLOGY II – SYSTEMS (3-3) CREDIT 4**
Prerequisite/Corequisite: A grade of C or better in PTAC 2438 or co-enrollment in PTAC 2438.
(Offered only in spring semester)
 A study of the various process systems, including related scientific principles. Topics included the purpose, function and operation of common process systems, such as distillation, reaction systems, heat exchanger, cooling towers, and steam generation.
- PTAC 2438 PROCESS TECHNOLOGY III – OPERATIONS (3-3) CREDIT 4**
Prerequisite: A grade of C or better in PTAC 1410 and 1432 or Instructor approval.
(Offered in spring semester)
 This course emphasizes activities associated with the hands-on operation of process equipment. Students write and follow procedures and operate actual equipment.
- PTAC 2446 PROCESS TROUBLESHOOTING (3-3) CREDIT 4**
Prerequisite/Corequisite: A grade of C or better in PTAC 2438 or co-enrollment in PTAC 2438.
(Offered only in spring semester)
 Instruction in the different types of troubleshooting techniques, procedures, and methods used to solve process problems. Topics include application of data collection and analysis, cause-effect relationships, and reasoning.

COURSE DESCRIPTIONS

- PTHA 1191 SPECIAL TOPICS IN PHYSICAL THERAPY ASSISTANT (1-0-0) CREDIT 1**
Prerequisite: Admission to the PTA Program
Prerequisites: PTHA 2409 – Therapeutic Exercise; PTHA 1413 – Physical Agents
(Offered only in spring semester)
 Topics address recently identified current events, skills, knowledge, and/or attitudes and behaviors pertinent to the technology or occupation and relevant to the professional development of the student. This course was designed to be repeated multiple times to improve student proficiency. Examines research methods used for the objective and systematic study and evaluation of physical therapy practices. Applies evidence in the area of physical therapy intervention and management to various client populations.
- PTHA 1266 PRACTICUM I – PHYSICAL THERAPIST ASSISTANT (0-0-15) (0-0-30) CREDIT 2**
Prerequisite: Admission to the PTA Program
(Offered only in summer session)
 Practical, general workplace training supported by an individualized learning plan developed by the employer, college, and student to apply specialized occupational theory, skills, and concepts. Direct supervision is provided by the clinical professional. This course provides the Physical Therapist Assistant (PTA) student a supervised application of previously learned techniques and skills in the rehabilitation of patients in a selected clinical facility affiliated with the college. The focus is on safe, legal, ethical and effective use of physical therapy interventions. This course also fosters the development of communication skills, interpersonal relationships and professionalism required for the healthcare field. Supervision of the student from beginning to intermediate level is provided by the staff of the affiliating institution and is coordinated by the college faculty. This course is the first of two Clinical Education courses in the PTA Program.
- PTHA 1301 PROFESSION OF PHYSICAL THERAPY (3-0-0) CREDIT 3**
Prerequisites: Texas Success Initiative complete
 Introduction to the profession of physical therapy and the role of the physical therapist assistant. This course provides general information regarding the field of physical therapy (P.T.) to those persons who have been admitted into the program or who have an interest in the profession of P.T. The course focuses on the history and development of the profession, its relationship to the health care delivery system in the United States, the settings utilized in the delivery of therapy, and an exploration of the roles and functions of the workers in the field and their part on the healthcare team. The development of the professional organization (American Physical Therapy Association) and its purpose are presented as well as the general ethical, legal principles and state laws relating to the delivery of physical therapy.
- PTHA 1305 BASIC PATIENT CARE SKILLS (2-4-0) CREDIT 3**
Prerequisites: Admission to the PTA Program
(Offered only in fall semester)
 This course covers the application of basic patient handling, functional skills, communication, and selected data collection techniques. It provides the future Physical Therapist Assistant (PTA) with an exposure to the duties that relate to the PTA scope of practice to include the principles and techniques of basic gait training with assistive devices, universal precautions, treatment preparation, client positioning, and clinic maintenance. The course also fosters the development of communication skills and interpersonal relationships with clients and colleagues in the health care field.
- PTHA 1321 PATHOPHYSIOLOGY FOR THE PTA (3-0-0) CREDIT 3**
Prerequisites: Admission to the PTA Program
(Offered only in summer session)
 The study of the pathophysiology of diseases/conditions commonly encountered in physical therapy. This course focuses on the etiology and characteristics of diseases of the body's systems as they relate to physical therapy and includes a consideration of the general principles of tissue injury, inflammation, and healing.
- PTHA 1413 FUNCTIONAL ANATOMY (3-3-0) CREDIT 4**
Prerequisites: Admission to the PTA Program
(Offered only in fall semester)
 This course introduces the student Physical Therapist Assistant to the relationship of the musculoskeletal and neuromuscular systems to normal and abnormal movement. It also discusses the relationship between physical laws and the biomechanical principles of joint motion as well as the concepts of normal posture and human locomotion contrasted with obvious posture and gait deviations.
- PTHA 1431 PHYSICAL AGENTS (2-6-0) CREDIT 4**
Prerequisites: Admission to the PTA Program
(Offered only in spring semester)
 The biophysical principles, physiological effects, intervention efficacy, and application of physical agents. It explores the use of thermal and athermal agents, mechanical traction, electrotherapy and electromagnetic modalities, as well as vasopneumatic compression. Students continue to use medical terms, charting skills, and role play to foster patient and family teaching as well as a deepening of self-awareness of communication skills and professionalism.
- PTHA 2201 ESSENTIALS OF DATA COLLECTION (1-4-0) CREDIT 2**
Prerequisites: Admission to the PTA Program
(Offered only in fall semester)
 The study of data collection techniques used to prepare the physical therapist assistant to assist in patient/client management. The student will perform data collection and measurement techniques specific to physical therapy and within the scope of practice of a physical therapist assistant. The student will utilize critical thinking skills to apply the data collected to decision making and problem solving related to patient management established by a physical therapist in the plan of care. Students continue to use medical terms, charting skills, and role play to foster patient and family teaching as well as communication skills and professionalism.

COURSE DESCRIPTIONS

- PTHA 2366 PRACTICUM II – PHYSICAL THERAPIST ASSISTANT (0-0-30) CREDIT 3**
Prerequisites: Admission to the PTA Program
(Offered only in spring semester)
 Practical, general workplace training supported by an individualized learning plan developed by the employer, college, and student to apply specialized occupational theory, skills, and concepts. Direct supervision is provided by the clinical professional. This course provides the fourth semester Physical Therapist Assistant (PTA) student a supervised application of previously learned techniques and skills in the rehabilitation of patients in selected clinical facilities affiliated with the college. The focus is on safe, legal, ethical and effective use of physical therapy interventions. This course also fosters the development of communication skills, interpersonal relationships and professionalism required for the healthcare field. Supervision of the student at the entry level is provided by the staff of the affiliating institutions and is coordinated by the college faculty.
- PTHA 2339 PROFESSIONAL ISSUES (3-0-0) CREDIT 3**
Prerequisites: Admission to the PTA Program
(Offered only in spring semester)
 A capstone course which engages the student in the discussion of professional issues and behaviors related to clinical practice and which prepares the student for transition into the workforce. This course provides future physical therapist assistants with the principles of organization, management, supervision, productivity levels and performance evaluations. Other topics include: the legal and ethical aspects of physical therapist assistants' occupation as described in the state board and national association regulations and standards; federal, state and private insurance regulation; professional liability insurance; job hunting skills; and the discussion of issues in the medical field as they impact physical therapy.
- PTHA 2409 THERAPEUTIC EXERCISE (2-6-0) CREDIT 4**
Prerequisites: Admission to the PTA Program
(Offered only in spring semester)
 An advanced course integrating previously learned and new skills/techniques and focusing on concepts, principles, and application of techniques related to therapeutic exercise and functional training. This course provides the student with a kinesiology based approach to the clinical applications used in the treatment and rehabilitation of the client with musculoskeletal and related diagnoses. An additional focus is on safe, legal, ethical, and appropriate use of therapeutic exercise. Physiological and therapeutic effects as well as indications and contraindications of exercise will be included. This course fosters the development of communication skills, interpersonal relationships, and professionalism required for the health care field. It also requires a high level of critical thinking skills related to implementing and modifying physical therapy interventions.
- PTHA 2435 REHABILITATION TECHNIQUES (2-4-0) CREDIT 4**
Prerequisites: Admission to the PTA Program
(Offered only in fall semester)
 Advanced course integrating previously learned and new skills/techniques into the comprehensive rehabilitation of selected musculoskeletal, neuromuscular, cardiopulmonary, and integumentary disorders. Students continue to use medical terms, charting skills, and role play to foster patient and family teaching as well as communication skills and professionalism.
- PTHA 2531 MANAGEMENT OF NEUROLOGICAL DISORDERS (3-6-0) CREDIT 5**
Prerequisites: Admission to the PTA Program
(Offered only in fall semester)
 Advanced course integrating previously learned and new skills/techniques into the comprehensive rehabilitation of selected neurological disorders. This course deals with the principles and clinical application of the functional activities and rehabilitation procedures relating to the management of therapy clients with neurological diagnoses. The course also fosters the development of communication skills, interpersonal relationships, and professionalism required for the health care field. It requires a high level of critical thinking related to implementing and modifying physical therapy interventions.
- RNSG 1219 INTEGRATE NURSING SKILLS I (1-3-0) CREDIT 2**
Prerequisite: Admission to the ADN Program
Corequisite: All concurrent RNSG and support courses within the designated semester required
 Study of the concepts and principles necessary to perform basic nursing skills for individualized care of patients across the life span; demonstrate competence in the performance of nursing procedures. Content includes knowledge, judgment, skills, and professional values within a legal/ethical framework. This course lends itself to an integrated approach.
- RNSG 1260 CLINICAL I – REGISTERED NURSING/REGISTERED NURSE (0-0-10) CREDIT 2**
Prerequisite: Admission to the ADN Program.
Corequisite: All concurrent RNSG and support courses within the designated semester required.
 A health-related, work-based learning experience that enables the student to apply specialized occupational theory, skills, and concepts. Direct supervision is provided by the clinical professional. Content from RNSG 1523 is applied to patients throughout the lifespan in a variety of health care settings in this course. Basic critical thinking skills are utilized to implement the nursing process for patients receiving direct nursing care.

COURSE DESCRIPTIONS

- RNSG 1261 CLINICAL TRANSITION-REGISTERED NURSING/REGISTERED NURSE (0-0-6) CREDIT 2**
Prerequisite: Admission to the ADN Program.
Corequisite: All concurrent RNSG and support courses within the designated semester required.
 A health-related, work-based learning experience that enables the student to apply specialized occupational theory, skills, and concepts. Direct supervision is provided by the clinical professional. Content from RNSG 1327 is applied to patients throughout the lifespan in a variety of health care settings in this course.
- RNSG 1327 TRANSITION FROM VOCATIONAL TO PROFESSIONAL NURSING (3-0-0) CREDIT 3**
Prerequisite: Admission to the ADN Program.
Corequisite: All concurrent RNSG and support courses within the designated semester required.
 Transition to the roles of the professional nurse and application of the nursing process to diverse clients of all ages, including the child-bearing family. Content includes health promotion, expanded assessment, analysis of data, critical thinking skills, and systematic problem solving process, pharmacology, interdisciplinary teamwork, communication, and applicable competencies in knowledge, judgment, skills, and professional values within a legal/ethical framework throughout the life span. This course lends itself to an integrated approach. Transition to the roles of the professional nurse and application of the nursing process to diverse patients of all ages, including the child-bearing family. Communication and critical thinking skills are emphasized. Legal and ethical aspects of vocational and professional nursing practice are compared. Mental health concepts are utilized in providing direct nursing care to all patients.
- RNSG 1523 INTRODUCTION TO PROFESSIONAL NURSING FOR INTEGRATED PROGRAMS (5-0-0) CREDIT 5**
Prerequisite: Admission to the ADN Program.
Corequisite: All concurrent RNSG and support courses within the designated semester required
 Introduction to the profession of nursing including the roles of the professional nurse as provider of patient-centered care, patient safety advocate, member of healthcare team, and member of the profession with emphasis on health promotion and primary disease prevention across the lifespan; essential components of the nursing health assessment; identification of deviations from expected health patterns; the application of clinical reasoning processes and clinical judgment to provide basic nursing care to patients across the lifespan; and applicable competencies in knowledge, judgment, skills, and professional values within a legal/ethical framework. This course lends itself to an integrated approach. Communication as the basis of the nurse-patient relationship is stressed. Applying the nursing process and simple nursing diagnoses to diverse patients of all ages; including the child-bearing family is introduced. Promotion of health and prevention of illness is related to the teaching role of the nurse; this includes principles of nutrition and safety. In addition, fundamental concepts of mental health for all patients are integrated in the course.
- RNSG 2361 CLINICAL II – REGISTERED NURSING/REGISTERED NURSE (0-0-12) CREDIT 3**
Prerequisite: Admission and progression through the program of study
Corequisite: All concurrent RNSG and support courses within the designated semester required.
 A health-related, work-based learning experience that enables the student to apply specialized occupational theory, skills, and concepts. Direct supervision is provided by the clinical professional. Content from RNSG 2504 is applied to patients throughout the lifespan in a variety of health care settings in this course.
- RNSG 2362 CLINICAL III – REGISTERED NURSING/REGISTERED NURSE (0-0-12) CREDIT 3**
Prerequisite: Admission and progression through the program of study
Corequisite: All concurrent RNSG and support courses within the designated semester required.
 A health-related, work-based learning experience that enables the student to apply specialized occupational theory, skills, and concepts. Direct supervision is provided by the clinical professional. Content from RNSG 2514 is applied to patients throughout the lifespan in a variety of health care settings in this course.
- RNSG 2363 CLINICAL IV – REGISTERED NURSING/REGISTERED NURSE (0-0-12) CREDIT 3**
Prerequisite: Admission and progression through the program of study
Corequisite: All concurrent RNSG and support courses within the designated semester required.
 A health-related, work-based learning experience that enables the student to apply specialized occupational theory, skills, and concepts. Direct supervision is provided by the clinical professional. Content from RNSG 2535 is applied to patients throughout the lifespan in a variety of health care settings in this course.
- RNSG 2504 INTEGRATED CARE OF THE PATIENT WITH COMMON HEALTH CARE NEEDS (5-0-0) CREDIT 5**
Prerequisite: Admission and progression through the program of study
Corequisite: All concurrent RNSG and support courses within the designated semester required.
 Application of clinical reasoning and clinical judgment to provide nursing care to diverse patients and families across the lifespan with common health care needs including, but not limited to, common childhood/adolescent diseases, uncomplicated perinatal care, mental health concepts, perioperative care, frequently occurring adult health problems, and health issues relating to aging. Emphasis on secondary disease prevention and collaboration with members of the interdisciplinary health care team. Content includes roles of the professional nurse and applicable competencies in knowledge, judgment, skills, and professional values within a legal/ethical framework. This course lends itself to an integrated approach.

COURSE DESCRIPTIONS

- RNSG 2514 INTEGRATED CARE OF THE PATIENT WITH COMPLEX HEALTHCARE NEEDS (5-0-0) CREDIT 5**
Prerequisite: Admission and progression through the program of study
Corequisite: All concurrent RNSG and support courses within the designated semester required.
 Application of clinical reasoning and clinical judgment to provide comprehensive nursing care to patients and families across the lifespan with complex health care needs including, but not limited to, complex childhood/adolescent diseases, complicated perinatal care, acute mental illness, complex perioperative care, serious adult health problems, and health issues related to aging. Emphasis on tertiary disease prevention, health maintenance/restoration and collaboration with members of the interdisciplinary health care team. Content includes the roles of the professional nurse and applicable competencies in knowledge, judgment, skills, and professional values within a legal/ethical framework. This course lends itself to an integrated approach.
- RNSG 2535 INTEGRATED PATIENT CARE MANAGEMENT (5-0-0) CREDIT 5**
Prerequisite: Admission and progression through the program of study
Corequisite: All concurrent RNSG and support courses within the designated semester required.
 Application of independent nursing interventions to care for patients and families throughout the lifespan whose health care needs may be difficult to predict. Emphasis on collaborative clinical reasoning, nursing leadership skills, and patient management. Content includes the significance of professional development, trends in nursing and health care, and applicable knowledge, judgment, skills, and professional values within a legal/ethical framework. This course lends itself to an integrated approach.
- RSPT 1113 RESPIRATORY CARE PHARMACOLOGY (0-3) CREDIT 1**
Prerequisite: Admission into the Respiratory Care Program
All concurrent RSPT courses within the designated semester required.
 A study of basic pharmacological principles/practices of cardiopulmonary drugs. Emphasis on classification, routes of administration, dosages/calculations, and physiological interaction.
- RSPT 1137 BASIC DYSRHYTHMIA INTERPRETATION (0-3) CREDIT 1**
Prerequisite: Admission into the Respiratory Care Program
All concurrent RSPT courses within the designated semester required.
 Study of electrophysiology of the heart and characteristics of cardiac dysrhythmias.
- RSPT 1141 RESPIRATORY HOME CARE/REHABILITATION (0-2) CREDIT 1**
Prerequisite: Admission and progression through the program of study
All concurrent RSPT courses within the designated semester required.
 A study of home care/rehabilitation equipment, procedures, and patient education; emphasizes treatment of patients in a home care and alternative settings.
- RSPT 1163 CLINICAL III – RESPIRATORY THERAPY/THERAPIST (0-0-6) CREDIT 1**
Prerequisite: Admission and progression through the program of study
All concurrent RSPT courses within the designated semester required.
 A health-related, work-based learning experience that enables the student to apply specialized occupational theory, skills, and concepts. Direct supervision is provided by the clinical professional.
- RSPT 1240 ADVANCED CARDIOPULMONARY ANATOMY PHYSIOLOGY (1-3) CREDIT 2**
Prerequisite: Admission into the Respiratory Care Program
All concurrent RSPT courses within the designated semester required.
 Provides an advanced presentation of anatomy and physiology of the cardiovascular and pulmonary system. Students will prepare a journal review related to the field of respiratory care using word processing, Internet research, and email.
- RSPT 1360 CLINICAL I – RESPIRATORY THERAPY/THERAPIST I (0-0-16) CREDIT 3**
Prerequisite: Admission into the Respiratory Care Program
All concurrent RSPT courses within the designated semester required.
(Offered only in fall semester)
 A health-related, work-based learning experience that enables the student to apply specialized occupational theory, skills, and concepts. Direct supervision is provided by the clinical professional.
- RSPT 1361 CLINICAL II – RESPIRATORY THERAPY/THERAPIST (0-0-16) CREDIT 3**
Prerequisite: Admission and progression through the program of study
All concurrent RSPT courses within the designated semester required.
(Offered only in spring semester)
 A health-related, work-based learning experience that enables the student to apply specialized occupational theory, skills, and concepts. Direct supervision is provided by the clinical professional.

COURSE DESCRIPTIONS

- RSPT 1410 RESPIRATORY CARE PROCEDURES I (2-6) CREDIT 4**
Prerequisite: Admission into the Respiratory Care Program
All concurrent RSPT courses within the designated semester required.
 Essential knowledge of the equipment and techniques used in the treatment of cardiopulmonary disease. The use of a microcomputer for application software is required.
- RSPT 1411 RESPIRATORY CARE PROCEDURES II (2-6) CREDIT 4**
Prerequisite: Admission and progression through the program of study
All concurrent RSPT courses within the designated semester required.
 Develops essential knowledge and skills of airway care and mechanical ventilation. The use of a microcomputer for application software is required.
- RSPT 2133 RESPIRATORY CARE CASE MANAGEMENT (0-3) CREDIT 1**
Prerequisite: Admission and progression through the program of study
All concurrent RSPT courses within the designated semester required.
(Offered only in spring semester)
 Investigation, organization, and presentation of case studies. An oral presentation and written research paper is required using word processing, Internet research, e-mail, and multimedia software.
- RSPT 2135 PEDIATRIC ADVANCED LIFE SUPPORT (0-3) CREDIT 1**
Prerequisite: Admission and progression through the program of study
All concurrent RSPT courses within the designated semester required.
 A comprehensive course designed to develop the skills for resuscitation of the infant and child. Includes strategies for preventing cardiopulmonary arrest and identification of high risk infants and children. May include certification based on American Heart Association Standards.
- RSPT 2139 ADVANCED CARDIAC LIFE SUPPORT (0-3) CREDIT 1**
Prerequisite: Admission and progression through the program of study
All concurrent RSPT courses within the designated semester required.
 Advanced Cardiac Life Support (ACLS) with an emphasis on airway management. Designed to develop skills for resuscitation of the adult. Includes strategies for managing and stabilizing the cardiopulmonary arrested patient. May include certification based on American Heart Association Standards.
- RSPT 2147 SPECIALTIES IN RESPIRATORY CARE (0-3) CREDIT 1**
Prerequisite: Admission and progression through the program of study
All concurrent RSPT courses within the designated semester required.
(Offered only in spring semester)
 Emerging and specialty practices in respiratory care. Oral presentations and written research papers are required using word processing, Internet research, email, and multimedia software.
- RSPT 2231 SIMULATIONS IN RESPIRATORY CARE (0-4) CREDIT 2**
Prerequisite: Admission and progression through the program of study
All concurrent RSPT courses within the designated semester required.
(Offered only in spring semester)
 Theory of clinical simulation examinations. Includes construction types, scoring, and mechanics of taking the computerized simulation examination. Students will be required to pass both the therapist multiple choice and clinical simulation self-assessment examinations. The use of a microcomputer for application software is required.
- RSPT 2243 RESEARCH IN RESPIRATORY CARE (1-2) CREDIT 2**
Prerequisite: Admission into the Respiratory Care Program
 All concurrent RSPT courses within the designated semester required
 Analysis of current respiratory care research material and determination of scientific validity. May include active clinical research.
- RSPT 2258 RESPIRATORY CARE PATIENT ASSESSMENT (1-2) CREDIT 2**
Prerequisite: Admission into the Respiratory Care Program
 All concurrent RSPT courses within the designated semester required.
 Integration of patient examination techniques, including patient history and physical exam, lab studies, x-ray, pulmonary function, arterial blood gases and invasive and non-invasive hemodynamics.
- RSPT 2310 CARDIOPULMONARY DISEASE (2-3) CREDIT 3**
Prerequisite: Admission and progression through the program of study
All concurrent RSPT courses within the designated semester required.
(Offered only in spring semester)
 Etiology, pathogenesis, pathology, diagnosis, history, prognosis, manifestations, treatment, and detection of cardiopulmonary diseases. This course will emphasize the various obstructive lung diseases.

COURSE DESCRIPTIONS

- RSPT 2325 CARDIOPULMONARY DIAGNOSTICS (2-4) CREDIT 3**
Prerequisite: Admission and progression through the program of study
All concurrent RSPT courses within the designated semester required.
(Offered only in spring semester)
 A study of physical, radiological, hemodynamic, laboratory, nutritional, and cardiopulmonary diagnostic assessments. Course will emphasize restrictive lung diseases, neuromuscular, and cardiac diseases. The use of a microcomputer for application software is required.
- RSPT 2360 CLINICAL IV – RESPIRATORY THERAPY/THERAPIST (0-0-16) CREDIT 3**
Prerequisite: Admission and progression through the program of study
All concurrent RSPT courses within the designated semester required.
(Offered only in fall semester)
 A health-related, work-based learning experience that enables the student to apply specialized occupational theory, skills, and concepts. Direct supervision is provided by the clinical professional.
- RSPT 2361 CLINICAL V – RESPIRATORY THERAPY/THERAPIST (0-0-16) CREDIT 3**
Prerequisite: Admission and progression through the program of study
All concurrent RSPT courses within the designated semester required.
(Offered only in spring semester)
 A health-related, work-based learning experience that enables the student to apply specialized occupational theory, skills, and concepts. Direct supervision is provided by the clinical professional.
- RSPT 2414 MECHANICAL VENTILATION (2-6) CREDIT 4**
Prerequisite: Admission and progression through the program of study
All concurrent RSPT courses within the designated semester required.
(Offered only in fall semester)
 The study of mechanical ventilation with emphasis on ventilator classification, methods, principles, and operational characteristics. Includes indications, complications, and physiologic effects/principles of mechanical ventilation. Emphasizes initiation, management, and weaning of ventilatory support. The use of a microcomputer for application software is required.
- RSPT 2453 NEONATAL/PEDIATRIC CARDIOPULMONARY CARE (2-6) CREDIT 4**
Prerequisite: Admission and progression through the program of study
All concurrent RSPT courses within the designated semester required.
(Offered only in fall semester)
 A study of neonatal/pediatric cardiopulmonary care. The use of a microcomputer for application software is required.
- SDEV 0012 STUDENT SUCCESS COURSE (NCBO) (0-1.25--25) CREDIT 0**
Corequisite: Must currently be on academic warning (first time cumulative GPA falls below 2.0) effective Spring 2021
 Psychology of learning and success. Examines factors that underlie learning, success, and personal development in higher education. Topics covered include information processing, memory, strategic learning, self-regulation, goal setting, motivation, educational and career planning, and learning styles. Techniques of study such as time management, listening and note taking, text marking, library and research skills, preparing for examinations, and utilizing learning resources are covered. Includes courses in college orientation and developments of students' academic skills that apply to all disciplines.
- SDEV 0301 STUDENT SUCCESS COURSE: LEARNING FRAMEWORKS (3-0) CREDIT 0**
 Psychology of learning and success. Examines factors that underlie learning, success, and personal development in higher education. Topics covered include information processing, memory, strategic learning, self-regulation, goal setting, motivation, educational and career planning, and learning styles. Techniques of study such as time management, listening and note taking, text marking, library and research skills, preparing for examinations, and utilizing learning resources are covered. Includes courses in college orientation and developments of students' academic skills that apply to all disciplines.
- A study of the research and theory in the psychology of learning, cognition, and motivation; factors that impact learning; and application of learning strategies. Theoretical models of strategic learning, cognition, and motivation serve as the conceptual basis for the introduction of college-level student academic strategies. Students use assessment instruments (e.g., learning inventories) to help them identify their own strengths and weaknesses as strategic learners. Students are ultimately expected to integrate and apply the learning skills discussed across their own academic programs and become effective and efficient learners. Students developing these skills should be able to continually draw from the theoretical models they have learned.
- SDEV 0301 does not count toward graduation from Victoria College. EDUC 1300 (3 credits) may be substituted for SDEV 0301.
- SOCI 1301# INTRODUCTION TO SOCIOLOGY (3-0) CREDIT 3 (080/090)**
Prerequisite: Texas Success Initiative complete in Reading and Writing.
 The scientific study of human society, including ways in which groups, social institutions, and individuals affect each other. Causes of social stability and social change are explored through the application of various theoretical perspectives, key concepts, and related research methods of sociology. Analysis of social issues in their institutional context may include topics such as social stratification, gender, race/ethnicity, and deviance.

COURSE DESCRIPTIONS

- SPAN 1411# BEGINNING SPANISH I (FOR BEGINNERS) (3-2) CREDIT 4**
Prerequisite: Texas Success Initiative complete in Reading.
(Offered only in fall semester)
 Basic Spanish language skills in listening, speaking, reading, and writing within a cultural framework. Students will acquire the vocabulary and grammatical structures necessary to communicate and comprehend at the beginner level.
- SPAN 1412# BEGINNING SPANISH II (3-2) CREDIT 4**
Prerequisite: A grade of D or better in SPAN 1411 or consent of instructor after departmental placement exam.
(Offered only in spring semester)
 Continued development of basic Spanish language skills in listening, speaking, reading, and writing within a cultural framework. Students acquire the vocabulary and grammatical structures necessary to communicate and comprehend at the high beginner to low intermediate level.
- SPCH 1311# INTRODUCTION TO SPEECH COMMUNICATION (3-0) CREDIT 3 (090)**
Prerequisite: Texas Success Initiative complete in Reading and Writing.
 Introduces basic human communication principles and theories embedded in a variety of contexts including interpersonal, small group, and public speaking.
- SPCH 1315# PUBLIC SPEAKING (3-0) CREDIT 3 (090)**
Prerequisite: Texas Success Initiative complete in Reading and Writing.
 Application of communication theory and practice to the public speaking context, with emphasis on audience analysis, speaker delivery, ethics of communication, cultural diversity, and speech organizational techniques to develop students' speaking abilities, as well as ability to effectively evaluate oral presentations. Student participation and presentations may be videotaped for educational purposes.
- SPCH 1318# INTERPERSONAL COMMUNICATION (3-0) CREDIT 3 (090)**
Prerequisite: Texas Success Initiative complete in Reading and Writing.
 Application of communication theory to interpersonal relationship development, maintenance, and termination in relationship contexts including friendships, romantic partners, families, and relationships with co-workers and supervisors. Student participation and presentations may be videotaped for educational purposes.
- SPCH 1321# BUSINESS AND PROFESSIONAL SPEAKING (3-0) CREDIT 3 (090)**
Prerequisite: Texas Success Initiative complete in Reading and Writing.
 Study and application of communication within the business and professional context. Special emphasis will be given to communication competencies in presentations, dyads, teams, and mediated formats.
- VNSG 1105 NCLEX-PN REVIEW (1-1-0) CREDIT 1**
Prerequisite: Admission to the Vocational Nursing Program. Successful completion of all Semester I and Semester II courses. This course is hybrid with an online component.
 Review of nursing knowledge and skills, study skills, stress management techniques, and test-taking strategies to prepare the graduate vocational nurse (GVN) to take the National Licensure Examination-Practical Nurse (NCLEX-PN).
- VNSG 1116 NUTRITION (1-0-0) CREDIT 1**
Prerequisite: Admission to the Vocational Nursing Program. All concurrent Semester I or equivalent VNSG courses for initial entry. Successful completion of this course within the past two years qualifies for exemption for the vocational nursing reentry student.
 Introduction to nutrients and the role of diet therapy in growth and development and in the maintenance of health. This is an online course and requires students to effectively manage time and utilize self-discipline to be successful.
- VNSG 1119 LEADERSHIP AND PROFESSIONAL DEVELOPMENT (1-0-0) CREDIT 1**
Prerequisite: Admission to the Vocational Nursing Program. Successful completion of all Semester I and II courses. Successful completion of this course within the past two years qualifies for exemption for the vocational nursing reentry student.
This is an online course and requires students to effectively manage time and utilize self-discipline to be successful.
 Study of the importance of professional growth. Topics include the role of the licensed vocational nurse in the multi-disciplinary health care team, professional organizations, and continuing education.
- VNSG 1122 VOCATIONAL NURSING CONCEPTS (1-0-0) CREDIT 1**
Prerequisite: Admission to the Vocational Nursing Program. All concurrent Semester I or equivalent VNSG courses for initial entry. Successful completion of this course within the past two years qualifies for exemption for the vocational nursing reentry student.
 Introduction to the nursing profession and its responsibilities. Includes legal and ethical issues in nursing practice. Concepts related to the physical, emotional, and psychosocial self-care of the learner/professional.

COURSE DESCRIPTIONS

- VNSG 1133 GROWTH AND DEVELOPMENT (1-0-0) CREDIT 1**
Prerequisite: Admission to the Vocational Nursing Program. All concurrent Semester I or equivalent VNSG courses for initial entry. Successful completion of this course within the past two years qualifies for exemption for the vocational nursing reentry student.
 Study of the basic aspects of growth and development throughout the life span. Focus on growth and development of the individual's body, mind, and personality as influenced by the environment.
- VNSG 1136 MENTAL HEALTH (1-0-0) CREDIT 1**
Prerequisite: Admission to the Vocational Nursing Program. All concurrent Semester I or equivalent VNSG courses for initial entry. Successful completion of this course within the past two years qualifies for exemption for the vocational nursing reentry student.
 Introduction to the principles and theories of positive mental health and human behaviors. Topics include emotional responses, coping mechanisms, and therapeutic communication skills.
- VNSG 1230 MATERNAL-NEONATAL NURSING (2-0-0) CREDIT 2**
Prerequisite: Admission to the Vocational Nursing Program; successful completion of all Semester I & Semester II courses. All concurrent VNSG semester courses for initial entry. Successful completion of this course within the past two years qualifies for exemption for the vocational nursing reentry student.
 A study of the biological, psychological, and sociological concepts applicable to the basic needs of the family including childbearing and neonatal care. Utilization of the nursing process in the assessment and management of the childbearing family. Topics include physiological changes related to pregnancy, fetal development, and nursing care of the family during labor and delivery and the puerperium.
- VNSG 1234 PEDIATRICS PEDIATRIC NURSING (2-0-0) CREDIT 2**
Prerequisite: Admission to the Vocational Nursing Program. All concurrent VNSG semester courses for initial entry. Successful completion of this course within the past two years qualifies for exemption for the vocational nursing reentry student
 Study of the care of the pediatric patient and family during health and disease. Emphasis on growth and development needs utilizing the nursing process. This is an online course and requires students to effectively manage time and utilize self-discipline to be successful.
- VNSG 1238 MENTAL ILLNESS (2-0-0) CREDIT 2**
Prerequisite: Admission to the Vocational Nursing Program. Successful completion of all Semester I and Semester II courses. All concurrent VNSG semester courses for initial entry. Successful completion of this course within the past two years qualifies for exemption for the vocational nursing reentry student.
 Study of human behavior with emphasis on emotional and mental abnormalities and modes of treatment incorporating the nursing process.
- VNSG 1260 CLINICAL – LICENSED PRACTICAL/VOCATIONAL NURSE (2-0-8) CREDIT 2**
Prerequisite: Admission to the Vocational Nursing Program. All concurrent VNSG courses within the designated semester are required.
 A health-related work-based learning experience that enables the student to apply specialized occupational theory, skills, and concepts. The clinical professional provides direct supervision.
- VNSG 1329 MEDICAL – SURGICAL NURSING I (3-1-0) CREDIT 3**
Prerequisite: Admission to the Vocational Nursing Program. All concurrent VNSG courses within the designated semester are required.
 Application of nursing process to the care of adult patients experiencing medical-surgical conditions in the health-illness continuum related to fluid and electrolytes and acid-base imbalances, respiratory, cardiovascular, hematological, lymphatic, endocrine, and neurological systems. Varieties of correlated clinical health care settings are utilized.
- VNSG 1420 ANATOMY AND PHYSIOLOGY FOR ALLIED HEALTH (4-1-0) CREDIT 4**
Prerequisite: Admission to the Vocational Nursing Program. All concurrent VNSG courses within the designated semester are required for initial entry. Successful completion of this course within the past two years qualifies for exemption for vocational nursing reentry student.
 Study of the structure (anatomy) and function (physiology) of the human body, including the neuroendocrine, integumentary, musculoskeletal, digestive, urinary, reproductive, respiratory, and circulatory systems.
- VNSG 1423 BASIC NURSING SKILLS (2-6-0) CREDIT 4**
Prerequisite: Admission to the Vocational Nursing Program. All concurrent VNSG courses within the designated semester are required.
 Mastery of basic nursing skills and competencies for a variety of health care settings using the nursing process as the foundation for all nursing interventions.
- VNSG 1432 MEDICAL – SURGICAL NURSING II (4-1-0) CREDIT 4**
Prerequisite(s): Admission to the Vocational Nursing Program. All concurrent VNSG courses within the designated semester are required.
 Application of nursing process to the care of adult patients experiencing medical-surgical conditions in the health-illness continuum related to the integumentary, musculoskeletal, immune, urinary, gastrointestinal, reproductive, sensory, and neurological systems. Varieties of correlated clinical health care settings are utilized.

COURSE DESCRIPTIONS

- VNSG 2260 CLINICAL-LICENSED PRACTICAL/VOCATIONAL NURSE (0-0-10) CREDIT 2**
Prerequisite: Admission into the Vocational Nursing Program. All concurrent VNSG courses within the designated semester are required.
 A health-related work-based learning experience that enables the student to apply specialized occupational theory, skills, and concepts. Direct supervision is provided by the clinical professional.
- VNSG 2331 ADVANCED NURSING SKILLS (1-5-0) CREDIT 3**
Prerequisite: Admission into the Vocational Nursing Program. All concurrent VNSG courses within the designated semester are required.
 Application of advanced level nursing skills and competencies in a variety of health care settings utilizing the nursing process as a problem-solving tool. This an online course and requires students to effectively manage time and utilize self-discipline to be successful. The lab section will meet face-to-face.
- VNSG 2461 CLINICAL-LICENSED PRACTICAL/VOCATIONAL NURSE (0-0-16) CREDIT 4**
Prerequisite: Admission to the Vocational Nursing Program. All concurrent VNSG courses within the designated semester are required.
 A health-related work-based learning experience that enables the student to apply specialized occupational theory, skills, and concepts. Direct supervision is provided by the clinical professional.
- WLDG 1417 INTRODUCTION TO LAYOUT AND FABRICATION (2-4) CREDIT 4**
Prerequisite: Instructor recommends completion of WLDG 1421
(Offered only in fall semester)
 A fundamental course in layout and fabrication related to the welding industry. Major emphasis on structural shapes and use in construction.
- WLDG 1421 WELDING FUNDAMENTALS (2-4) CREDIT 4**
(Offered only in fall semester)
 An introduction to the fundamentals of equipment used in oxy-fuel and arc welding, including welding and cutting safety, basic oxy-fuel welding and cutting, basic arc welding processes, and basic metallurgy.
- WLDG 1430 INTRODUCTION TO GAS METAL ARC WELDING (2-4) CREDIT 4**
***Instructor recommends completion of or enrollment in WLDG 1421**
(Offered only in fall semester)
 Principles of gas metal arc welding, setup and use of gas metal arc welding (GMAW) equipment, and safe use of tools/equipment. Instruction in various joint designs.
- WLDG 1434 INTRODUCTION TO GAS TUNGSTEN ARC WELDING (2-4) CREDIT 4**
***Instructor recommends completion of WLDG 1421**
(Offered only in spring semester)
 Principles of gas tungsten arc welding (GTAW), including setup, GTAW equipment. Instruction in various positions and joint designs.
- WLDG 2406 INTERMEDIATE PIPE WELDING (2-6) CREDIT 4**
Prerequisite: Instructor recommends completion of WLDG 2443
(Offered only in spring semester)
 A comprehensive course on the welding of pipe using the shielded metal arc welding (SMAW) and/or other processes. Welds will be done using various positions. Topics covered include electrode selection, equipment setup, and safe shop practices.
- WLDG 2435 ADVANCED LAYOUT AND FABRICATION (2-4) CREDIT 4**
***Instructor recommends completion of WLDG 1417**
(Offered only in spring semester)
 An advanced course in layout and fabrication. Includes production and fabrication of layout, tools, and processes. Emphasis on application of fabrication and layout skills.
- WLDG 2443 ADVANCED SHIELDED METAL ARC WELDING (2-4) CREDIT 4**
Prerequisite: A grade of C or better in WLDG 1421 or department approval
(Offered only in fall semester)
 Advanced topics based on accepted welding codes. Training provided with various electrodes in shielded metal arc welding processes with open V-groove joints in all positions.
- WLDG 2451 ADVANCED GAS TUNGSTEN ARC WELDING (2-4) CREDIT 4**
Prerequisite: A grade of C or better in WLDG 1434 or department approval
(Offered only in spring semester)
 Advanced topics in GTAW welding, including welding in various positions and directions.
- WLDG 2452 ADVANCED FLUX CORED ARC WELDING (2-4) CREDIT 4**
***Instructor recommends completion of WLDG 1430**
(Offered only in spring semester)
 Advanced concepts of flux cored arc welding of structural and fabricated steel products. Skill development in multi-pass fillet and V-groove welding.

Index

Symbols

45-Hour Limit 36

A

Academic Calendar 12
 Academic Fresh Start 22
 Academic Probation 30
 Academic Standing 30
 Academic Suspension 30
 Academic Transfer 28
 Academic Warning 30
 Academy of Lifelong Learning 109
 Administrative Council 124
 Admission 16, 18
 Admissions & Records 70
 Adult Education 29
 Advising & Counseling Services 70
 Allied Health Continuing Education 115
 Associate of Applied Science Degree 28
 Associate of Arts Interdisciplinary Studies Degree 26
 Associate of Science Interdisciplinary Studies Degree 27
 Attendance 46
 Auditing a Class 36

B

Bacterial Meningitis 21
 Business Management 77

C

Career Services 70
 CARE Team 71
 Carpentry 109
 Catalog Year Designation for Degree and/or Certificate Requirements 40
 Certificate in a Career & Technical Program 28
 Certificate in an Allied Health Program 28
 Child Care Assistance 72
 Classification of Students 36
 Clery Act Report 48
 Computer Access 73
 Computer Applications 109
 Confidentiality and Access of Student Records 47
 Construction Site Safety Technician (CSST) 109
 Core Curriculum 23, 25
 Counseling Services 70
 Course Definitions 32
 Course Descriptions 141
 Course Fees 53
 Course Load 32
 COVID Vaccination 119
 Credit by Exam 33
 Crime Awareness and Prevention Programs 47
 Criminal Justice 79
 Cultural Enrichment 123
 Curriculum 23

D

Dean's List 40
 Degree/Certificate Requirements 25
 Developmental Education 29

Directors 124
 Directory Information 47
 Disability Services 71
 Distance Education 39
 Dropping a Course 37

E

Electrical 110
 Electrocardiogram (EKG) Technician 115
 Electronics Technology/Instrumentation 81
 Emergency Medical Services 84
 Emerging Technology Complex 122
 Employee Training 109
 Enrollment Services 71
 Environmental Protection Agency (EPA) Technician Certification 109
 EPA Technician Certification 110

F

Faculty 125
 Fall 2006 and after Beginning Freshmen (30-Hour Rule) 36
 Family Education Rights and Privacy Act of 1974 47
 Federal Financial Aid Return of Title IV Funds Policy 56
 Fees 52
 Fiber Optics Technician 110
 Final Exams 40
 Financial Aid 60
 Financial Aid Office 71

G

Gonzales Center 122
 Grade Point Average (GPA) 31
 Grades 31
 Graduation Application 25
 Graduation, Employment, and Licensure Exam Pass Rates 47
 Graduation Participation and Honors 41
 Grants 62
 Guided Pathways 31

H

Hazlewood Act 67
 Heating, Ventilation & Air Conditioning (HVAC) 110
 High School Dual Enrollment Tuition & Fees 52
 History of VC 130

I

Illegal Drugs or Alcohol 48
 Immunizations 21
 Industrial Electrician Certified Plus Performance Verification 110
 Industrial Training 109
 Instructional Council 124
 Instrumentation 81

J

Job Competency Guarantee 42

K

KEY Center 72

L

Laboratory Fees 53
 Law Enforcement 80
 Law Enforcement Basic Peace Officer Course 113

- Learning Labs 74
- Legislation Concerning Courses Attempted More Than Twice 37
- Legislation Concerning Physical Education Courses 37
- Loans 63
- Locally Articulated Credit 36
- Locations 122
- M**
- Main Campus Buildings 130
- Math Pathways 133
- Medical Assisting Program 115
- Medical Coding 116
- Medication Aide Program 116
- Mental Health Technician 117
- Messages and Deliveries to Students 47
- Millwright 111
- Montgomery GI Bill® 66
- Motorcycle Safety 113
- N**
- Name, Social Security Number, Contact Information Changes 47
- National Society of Leadership and Success (NSLS) 73
- NCCER Core Curriculum: Introductory Craft Skills 110
- Network Engineering Technology and Cloud Computing 86
- Nurse Aide Program 117, 118
- Nursing-Associate Degree 89
- Nursing-Vocational 95
- P**
- Payments Office 72
- Pharmacy Technician Program 118
- Phi Theta Kappa 73
- Phlebotomy 119
- Physical Therapist Assistant Program 98
- Pipefitting 111
- Pirate Orientation 22
- Plumbing 111
- Power Line Worker 112
- Process Technology 100
- Protections for Pregnant and Parenting Students (SB 412) 48
- R**
- Reading and Writing Pathways 137
- Real Estate 113
- Refund Policy 55
- Refunds for Noncredit Courses 56
- Registration 32
- Reinstatement Requests 37
- Repeating Courses 65
- Reporting Sexual Assault and Other Sexual Misconduct 48
- Residency Definitions for Tuition & Fees Purposes 54
- Residency Requirements 21
- Residency Verification Requirements 54
- Respiratory Care Program 102
- S**
- Satisfactory Academic Progress (SAP) Policy 64
- Scaffold Worker 112
- Schedule Changes 37
- Scholarships 61
- Semesters, Sessions, and Credit 32
- Six Drop Rule 37
- Student Conduct 44, 74
- Student Employment 64
- Student Government 73
- Student Identification Cards & Badges 73
- Student Life 72
- Student Resources 73
- Student Services 70
- Students' Right to Review Information 22
- Success Coaching 74
- Support Services 71
- Survivors and Dependents Educational Assistance Program (DEA-Chapter 35) 66
- T**
- Terms To Know 7
- Testing 19
- Testing Center 72
- Testing Fees 52
- Texas Guided Pathways 22
- Texas Success Initiative (TSI) 19
- Texas Workforce Solutions Vocational Rehabilitation Services 67
- Transcripts 47
- Transfer Credit Policy 42
- Transfer Disputes 41
- Transfer of Credit 41
- Transfer of Credits from Another Institution to VC 42
- Truck Driving 114
- TSI 19, 20
- Tuition 50
- Tuition Exemption/Waiver Program 57
- Tuition Fees 52
- Tuition Rebate 55
- V**
- VC Mission, Vision, & Values 4
- Veterans Benefits 66
- Veterans' Educational Assistance Program (VEAP) 66
- Veterans Services 71
- Veterinary Assistant Program 119
- Victoria College Board of Trustees 124
- Victoria College Foundation Board of Directors 60
- W**
- Warehouse Vehicle Operations 112
- Welding 104, 112
- Wireless (Wi-Fi) Buildings 123
- Withdraw 38
- Withdrawal 56
- Workforce & Continuing Education 108, 123
- Workforce Solutions Golden Crescent 67
- Z**
- Zelda L. Allen School of Nursing 122

Addendum

Addition: Page 7 Terms to Know

Academic Intervention: Students are placed on academic intervention when their cumulative GPA drops below 2.0 after being on good standing.

Academic Recovery: Students who are on academic intervention and fail to increase their cumulative GPA to a 2.0 or higher at the end of the semester will be placed on academic recovery.

Addition & Revision: Page 20 TSI Exemptions

Exemptions:

a. The following students shall be exempt from the requirements of this title:

(1) Standardized test scores

ACT	ACT taken before February 15, 2023 Composite score 23: with a minimum of 19 on the English test	5-year limit
	Composite score 23: with minimum of 19 on the mathematics test	
	ACT taken after February 15, 2023 Combined score of 40 on English & Reading (E+R) tests Mathematics minimum score of 22	
SAT	SAT taken before March 2016 Combined critical reading and math score of 1070 with a minimum of 500 on the critical reading test Combined critical reading and math score of 1070 with a minimum of 500 on the math test	5-year limit
	SAT taken March 2016 and after Evidence-based reading and writing minimum score of 480 Mathematics minimum score of 530	
STAAR	Minimum score of 4000 on the English III test	5-year limit
	Minimum score of 4000 on the Algebra II test	
11th Grade Exit Level-TAKS	Minimum score of 2200 on the math section	5-year limit
	Minimum score of 2200 on the English language-arts section with a writing subsection score of at least a 3	
Texas GED	RLA (Reasoning through Language Arts) minimum score of 165 can be used for ELAR	5-year limit
	Mathematical Reasoning minimum score of 165 can be used for MATH	
Texas HiSET	Reading minimum score of 15 and Writing minimum score of 15 can be used for ELAR exemption	5-year limit
	Mathematics minimum score of 15 can be used for MATH	

(2) A student who has graduated with an associate or baccalaureate degree from an institution of higher education

(3) ~~A student who transfers to an institution from a private or independent institution of higher education or an accredited out-of-state institution of higher education and who has satisfactorily completed college-level coursework as determined by the receiving institution~~

(4) ~~A student who has previously attended any institution and has been determined to have met readiness standards by that institution~~

A student who has previously enrolled in any public, private, or independent institution of higher education or an accredited out-of-state institution of higher education and

A. has met college readiness standards in mathematics, reading, or writing by that institution, or

B. A student who has satisfactorily completed college-level coursework in mathematics, reading or writing with a grade of 'C' or better

(5) A student who is enrolled in a certificate program of one year or less (Level 1 Certificates) at a public junior college, a public technical institute, or a public state college

(6) A student who is serving on active duty as a member of the armed forces of the United States, the Texas National Guard, or as a member of a reserve component of the armed forces of the United States and has been serving for at least three years preceding enrollment

(7) A student who on or after August 1, 1990, was honorably discharged, retired, or released from active duty as a member of the armed forces of the United States or the Texas National Guard or service as a member of a reserve component of the armed forces of the United States

b. An institution may exempt a non-degree-seeking or non-certificate-seeking student.

c. Any student who has been determined to be exempt in mathematics, reading, and/or writing under subsection (a) or (b) of this section shall not be required to enroll in developmental coursework and/or interventions in the corresponding area of exemption.

d. A student who successfully completes a college preparatory course (makes at least a 70 on the final exam) is exempt for a period of 24 months from the date of high school graduation with respect to the content area of the course. The student must enroll in the student's first college-level course in the exempted content area in the student's first year of enrollment. ~~This exemption applies only at Victoria College.~~



www.VictoriaCollege.edu
(361) 573-3291